

# SEISMIC RESTRAINT OF BUILDING CONTENTS

A. W. Charleson<sup>1</sup>

## ABSTRACT

This paper describes the background to and development of the first New Zealand Standard on the seismic restraint of building contents. The implications of its targeted non-specialist use are discussed, and new concepts such as "frequently occupied areas" explained.

## INTRODUCTION

At present not all aspects of personal safety for occupants of buildings in the event of earthquake shaking are covered by New Zealand Standards. Safety of building structures themselves, heavy components such as precast concrete panels and mechanical services are provided for. However the situation for suspended ceilings, proprietary raised floors and partitions is less clear with the current de facto adoption of various industry standards. It is anticipated that the situation will improve with the proposed updating of NZS 4219 [SANZ, 1983]. Setting aside the question of earthquake risk buildings, currently being addressed by the New Zealand National Society for Earthquake Engineering, it is believed that with the imminent finalization of the draft Standard on Seismic Restraint of Building Contents [Standards New Zealand, 1994] and its publication, all presently acknowledged aspects of building seismic safety will have been addressed by New Zealand Standards.

The quite limited body of literature about mitigation of seismic damage to contents has already been summarised [Charleson, 1991], and this material has provided background information for the development of the Standard. There are no known examples of similar Codes or Standards overseas.

In contrast to existing New Zealand seismic regulations, it has been decided that the new Standard should not be too technical. Relevant to all built environments including commercial, retail, office and home, it is intended that it be used by non-specialist people, as diverse as building and office managers through to householders; those most likely to be affected by seismic damage to contents. Also, and related to that decision was the need for the Standard to have a realistic and practical orientation. In order to gain both industry and public acceptance, it must not be unduly onerous in its requirements. Given the relatively low level of public awareness regarding the dangers posed by unrestrained contents, there is potential for an overly negative reaction.

A published format including many practical illustrated restraint examples was also appropriate. Particular attention has been paid to reducing potential inconveniences to day-to-day functioning or unacceptable visual impacts of the seismic restraint systems. An attempt has also been made to give non-specialists an appreciation of levels of risk to contents by presenting them as clearly as possible. The degree of public support for the Standard after a familiarisation period will indicate the success of the approaches outlined.

It is proposed that the Standard be optional initially, until its extent of acceptance indicates it should be included within the framework of the New Zealand Building Code. Domestic dwellings have been excluded specifically from the Standard, to prevent possible unwarranted domestic interference by a Territorial Authority. However, it is hoped many householders will adopt many of the practical measures to restrain their own chattels.

The Standard has two aims. First, to reduce the risk of injury to people from falling and flung items and to ensure access to and from a building after an earthquake is not impaired by items which have moved during the shaking; and second, to reduce the risk of damage to contents themselves. This latter aim is particularly relevant where items are valuable or irreplaceable, or where their integrity is essential to the efficient functioning of a building or enterprise.

## DETERMINING NECESSITY OF RESTRAINTS

In many situations, potentially hazardous items (defined as weighing between 5 kg and 300 kg) will not require restraint if the various criteria outlined below are met.

The intensity of shaking at which building contents are likely to become hazardous has been assessed to be MMVII. For the purposes of the Standard, if the probability of MMVII intensity shaking within a period of twenty five years is greater than thirty percent, the level of risk is considered sufficiently high that potentially hazardous items should be restrained. A table of locations and probabilities of MMVII occurrence, and a map

<sup>1</sup> *School of Architecture, Victoria University, Wellington (Member)*

showing the two different risk zones are provided. This method of expressing seismic risk was chosen so that non-specialists could appreciate clearly their level of risk exposure. The shape of the zone where the probability of MMVII intensity occurrence is greater than thirty percent resembles closely the area for which the NZS 4203 zone factor Z is equal to or greater than 0.8.

The decision as to whether or not restraints are mandatory for a given building is further complicated by the necessary consideration of Building Category and building height. The Building Category in NZS 4203 [Standards New Zealand, 1992] is an expression of a building's importance to the community. More important buildings are likely to require mandatory provision of restraints. Regarding building height, it is considered prudent to require restraint of *all* potentially dangerous items on seventh floors and above due to the likelihood of relatively high lateral accelerations, irrespective of seismic risk and other factors such as seismicity.

If the consideration of seismic risk, Building Category and building height indicates restraint is mandatory, three further secondary factors need investigation. That is, the height of an item above floor level, its potential to block egress, and the intensity of space occupancy in its immediate vicinity.

If an item's height is less than 1.2 m above floor level it is not considered generally to be hazardous. However, if it weighs over 40 kg and has the potential to block egress by either toppling or sliding and thus preventing doors from being opened or people moving past, then restraint is required. If located higher than 1.2 m above a floor surface an item should be restrained if it is either in a Frequently Occupied Area or within 3 m of an escape route. A Frequently Occupied Area is defined in the Standard as an area in which one of the following uses occur:-

- (a) a person is seated for more than 10 hours per week,
- (b) people may queue or gather, or
- (c) people pass-by more frequently than one person per minute more than 10 hours per week.

This consideration of occupancy intensity further refines the level of risk and is consistent with the view that infrequently occupied spaces such as file and other storage spaces may not warrant having their items restrained.

Flow chart diagrams are provided in the Standard to make it easier to navigate through the various criteria to determine if mandatory restraints are required.

It will be appreciated that many of the decisions incorporated into the Standard have been based on a combination of engineering judgement and common sense. Further research, including findings from future damaging earthquakes, will enable some of these provisions to be refined.

## RESTRAINT REQUIREMENTS

A restraint is intended to prevent a potentially hazardous item being flung horizontally, falling or overturning. Where egress will be unaffected, sliding of squat items is permitted. This permits office furniture, including most work stations which will slide before overturning, to remain unrestrained. The approach has been to allow as much flexibility to office furniture rearrangement as possible, and focus on restraining more hazardous items. Obviously it would be safer if every item was

restrained, but if the requirements of this first Standard are seen to be unrealistic or too onerous there is a risk of it never gaining public and industry acceptance.

Restraint strengths can be determined either directly from NZS 4203:1992 or by a simplified procedure in the Standard. A table provides multiplying factors to calculate a restraint design strength. For items at ground, first and higher floors the factors are 1.0, 1.5 and 2.0 respectively. Based on the requirements of the Loadings Standard, they are generally conservative except for the upper-most storeys of a multistorey building. It has been assumed that items are brittle ( $\mu_p=1$ ) and maximum values of Z and R apply. As seismic hazard is expected to be more strongly correlated to peak acceleration than to an average level of sustained shaking,  $S_p$  has been increased from 0.67 to 1.0, but the NZS 4203:1992 1.5 factor for "where in the event of failure of connections there is a risk to persons" has been waived to avoid an overly conservative approach.

To assist with the detailed design of restraints the Standard provides strengths for various fixing components such as curtain-wire and hollow wall anchors. Small diameter expansion anchor strengths, useful for the restraint of lighter items are also provided.

## EXAMPLES OF SEISMIC RESTRAINTS

The longest section of the Standard consists of detailed illustrated examples of restraints for common items. They are listed in Table 1, and Figures 1 and 2 provide two typical examples. There are two types of restraint; Type 1 will primarily mitigate hazards to people with Type 2 restraints intended to prevent damage to items. Each restraint has been designed for a ground floor location using the Standard's simplified design method. It is expected that some of the examples will require modification to suit particular physical circumstances. There will often be other techniques to achieve satisfactory restraint. The objective has been to demonstrate at least one practical and cost effective method. It is hoped that the Standard will encourage some manufacturers to develop suitable restraints for their own products.

## CONCLUSION

The publishing of this Standard will represent a significant improvement in the mitigation of seismic hazard to people in buildings. Intended to be used by non-technical people, the Standard outlines the seismic risk to contents, and after consideration of a wide range of relevant criteria, explains what items in a building should be restrained. An important emphasis throughout the document has been to ensure the requirements are not unrealistic or too onerous. It is considered essential that the Standard first be accepted by society before being included within the New Zealand Building Code.

## ACKNOWLEDGEMENTS

The constructive input from the other members of the Standard's committee is gratefully acknowledged.

Table 1 List of example restraints

## REFERENCES

**Type 1 Protection**

Floor mounted appliances  
 Bench and shelf mounted appliances  
 Bookcase, cabinet or shelves restrained by wall  
 Free-standing shelves, cupboards and lockers  
 Low equipment or desk supporting heavy equipment  
 Heavy storage shelves and cabinets  
 Ornaments on shelves  
 Wall hung items  
 Hanging items  
 Upright piano restrained by wall  
 Electric hot water cylinders  
 Equipment on desks, benches or shelves  
 Free-standing equipment  
 Items in storage racks  
 Items in cupboards and drawers  
 Office screens and workstations  
 Emergency battery power racks  
 Hazardous materials

**Type 2 Protection**

Fragile ornaments on benches or shelves  
 Fragile items in cupboards on shelves  
 Domestic water header tanks

Charleston A.W. 1991. Mitigation of earthquake damage to household chattels and light office equipment. *Proceedings of the Pacific Conference on Earthquake Engineering*, Auckland, pp. 281-290.

Standards Association of New Zealand. 1983. *Specification of seismic resistance of engineering systems in buildings*, NZS 4219. Wellington, New Zealand.

Standards New Zealand. 1992. *Code of practice for general structural design and design loadings for buildings*. NZS 4203. Wellington, New Zealand.

Standards New Zealand. 1994. *Draft standard for the seismic restraint of building contents*. DZ 4104. Wellington, New Zealand.

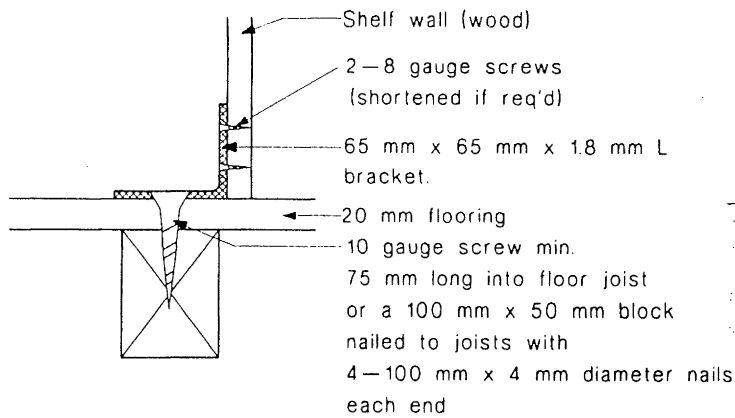
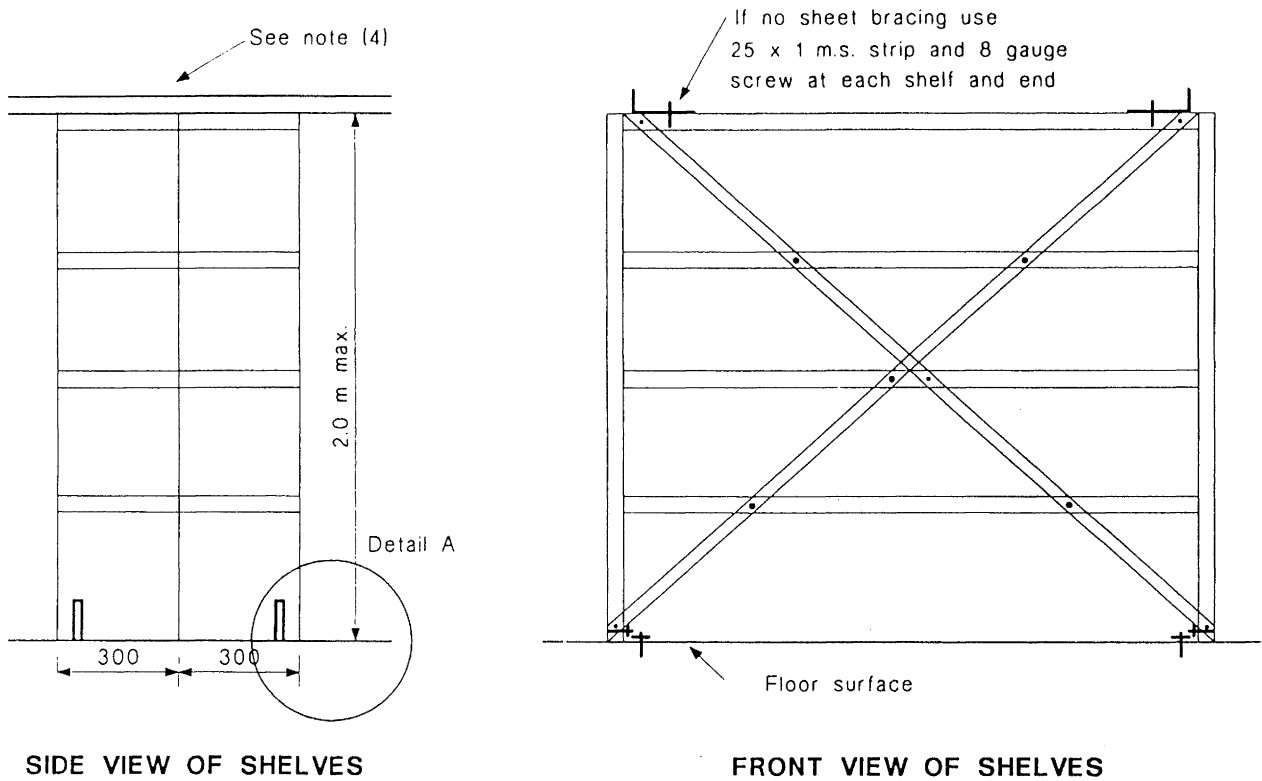

**DETAIL A - TIMBER FLOOR**

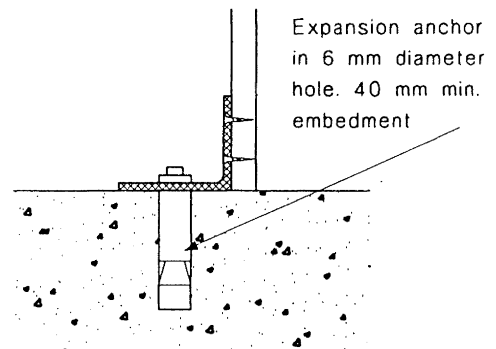

**DETAIL A - CONCRETE FLOOR**

**NOTE—**

- (1) Weight of shelves plus contents assumed 200 kg.
- (2) When units are paired they must be screwed or bolted together so as they act as one unit under seismic loads.
- (3) For light steel cabinets and contents fix steel angles to steel walls with 2-5 mm diameter bolts.
- (4) For height/width greater than 4, use wall and floor restraints (figure 6.3), or provide bracing along tops of units to load bearing structure. (Requires specific design).

**FIGURE 1 Suggested seismic restraint of light, free standing shelves, cupboards and lockers.**

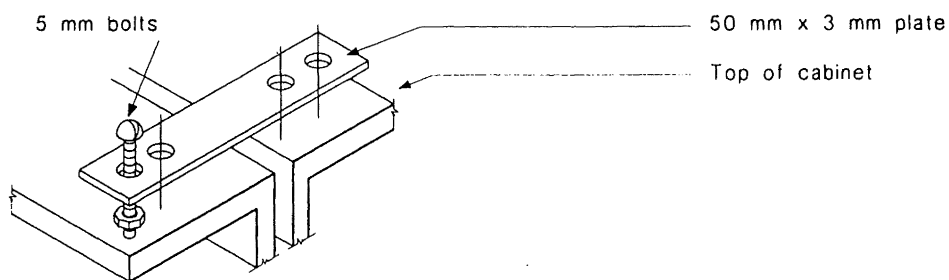
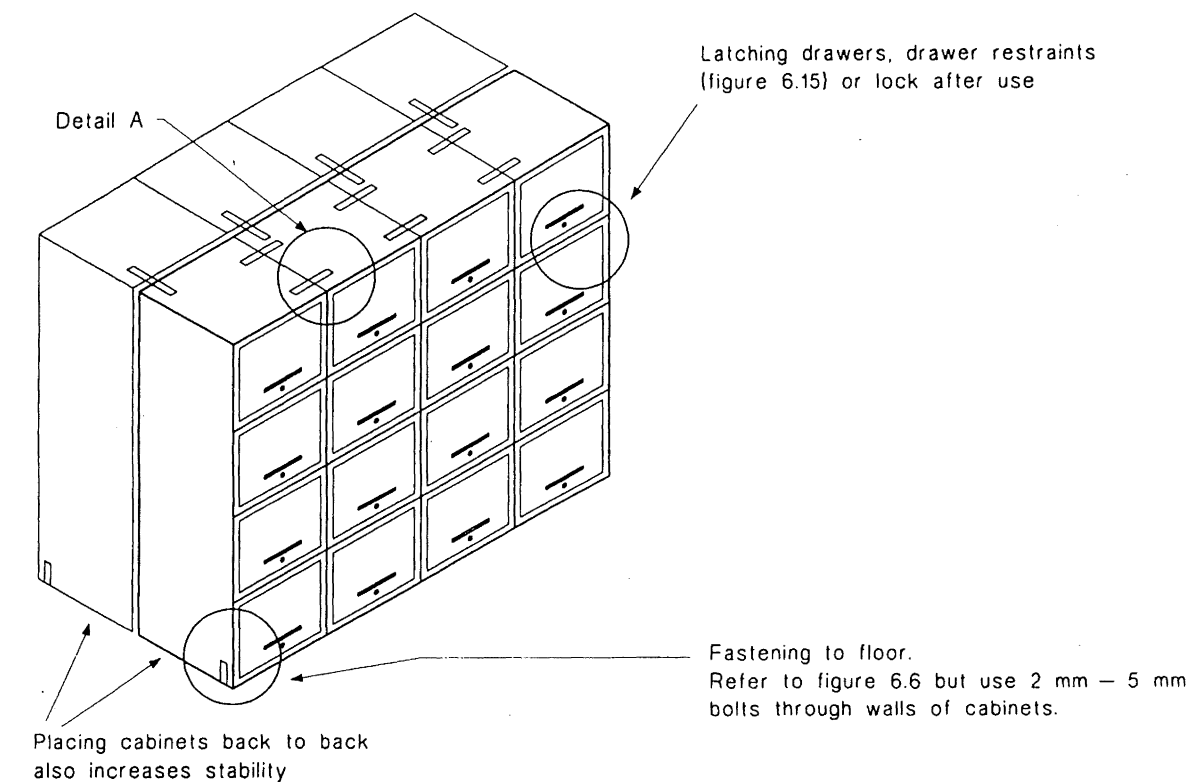

**DETAIL A**

**NOTE –**

- (1) Bolting cabinets together increases stability.
- (2) Bolting may be done through cabinet walls.
- (3) For single row of cabinets restrain tops to wall (if possible) and bottom of cabinets to floor.

**FIGURE 2** Suggested seismic restraint of filing cabinets.