

## THE AUGUST 8, 1993 GUAM EARTHQUAKE Reconnaissance Report

D.R. Brunson<sup>1</sup>

### SUMMARY

*This report on the 1993 Guam earthquake summarises the earthquake and resulting damage to structures and lifelines. The particular interest in this event, which is considered to represent a serviceability limit state earthquake, was the response of relatively modern high-rise buildings.*

### INTRODUCTION

Guam is an island of 540 square kilometres situated in Micronesia, in the western Pacific Ocean, with a population of approximately 130,000. It is a territory of the USA, and a key communications centre, with US Naval and Airforce bases present on the island. Guam functioned primarily as a naval outpost until the commencement of commercial and tourist development in the late 1960's and early 1970's. Tourism is the island's largest industry, and is estimated to bring 700,000 tourists to the island each year. The location of Guam is indicated in Figure 1.

There are approximately 32,000 houses on Guam, but only of the order of thirty high-rise (greater than eight storey) buildings. This small sample of high rise buildings contains several that were constructed in the early 1970's to earlier design codes, with the majority being of current design. Virtually all of the current building stock was constructed after World War Two, with the majority of houses being constructed after the mid 1960's. The absence of buildings of early vintage and/or poorer construction enabled a clearer picture of the response of modern structures to be obtained, and this is one of the key points of interest of this event.

The earthquake occurred at 18:34 on Sunday 8 August, 1993. The Richter magnitude was recorded as 8.1. Intensities proved difficult to assess, due principally to the absence of unreinforced structures. It is considered that a reasonable estimate of the average intensity would be MM VIII.

The earthquake was felt by all on the island as a prolonged and disturbing motion. Difficulty in standing, bordering on impossibility, was noted by many. The duration of strong shaking was reported as 40 to 50 seconds. Notwithstanding this, there was not widespread damage to either the ground or to buildings. Three multistorey structures, including a twelve storey hotel complex completed in June of this year, required demolition as a consequence of the earthquake.

No deaths were recorded, with approximately 50 people requiring hospital treatment. The cost of damage resulting from this earthquake is estimated to be in excess of US\$200 million.

Despite the presence of three strong ground motion instruments on Guam, no recordings were recovered. The Earthquake Engineering Research Institute (EERI) reconnaissance team concluded that peak acceleration amplitudes did not exceed 0.25g, and that high frequencies (ie. greater than 5 Hz) were not present [1].

This reconnaissance visit concentrated on the civilian sections of the island, rather than the military sites. There were few tall structures in the Navy and Airforce areas, and it is understood that there was comparatively little damage in these areas.

The scope of investigation of the hotel buildings, which make up the majority of high-rise buildings on Guam, was restricted due to the extremely competitive nature of the tourist industry. There was considerable reluctance on the part of owners and operators to permit entry to damaged hotels.

The writer arrived in Guam two and a half weeks after the earthquake, and stayed on the island for one week. The assistance of the Earthquake Commission in meeting the travel costs associated with this reconnaissance is gratefully acknowledged.

### SEISMOLOGY

The island of Guam is approximately 110 km from the Mariana Trench, where the Pacific Plate dives below the eastern edge of the Phillipine Plate. The greatest measured ocean depth of approximately 11.3 km lies in the Mariana Trench southwest of Guam. Figure 1 illustrates the different rates of movement of the two plates.

The epicentre was placed at 60 km south of Agana, the capital of Guam, with a focal depth of 61 km. There is a

<sup>1</sup> Brunson Cathie Ltd, Lower Hutt (Member)

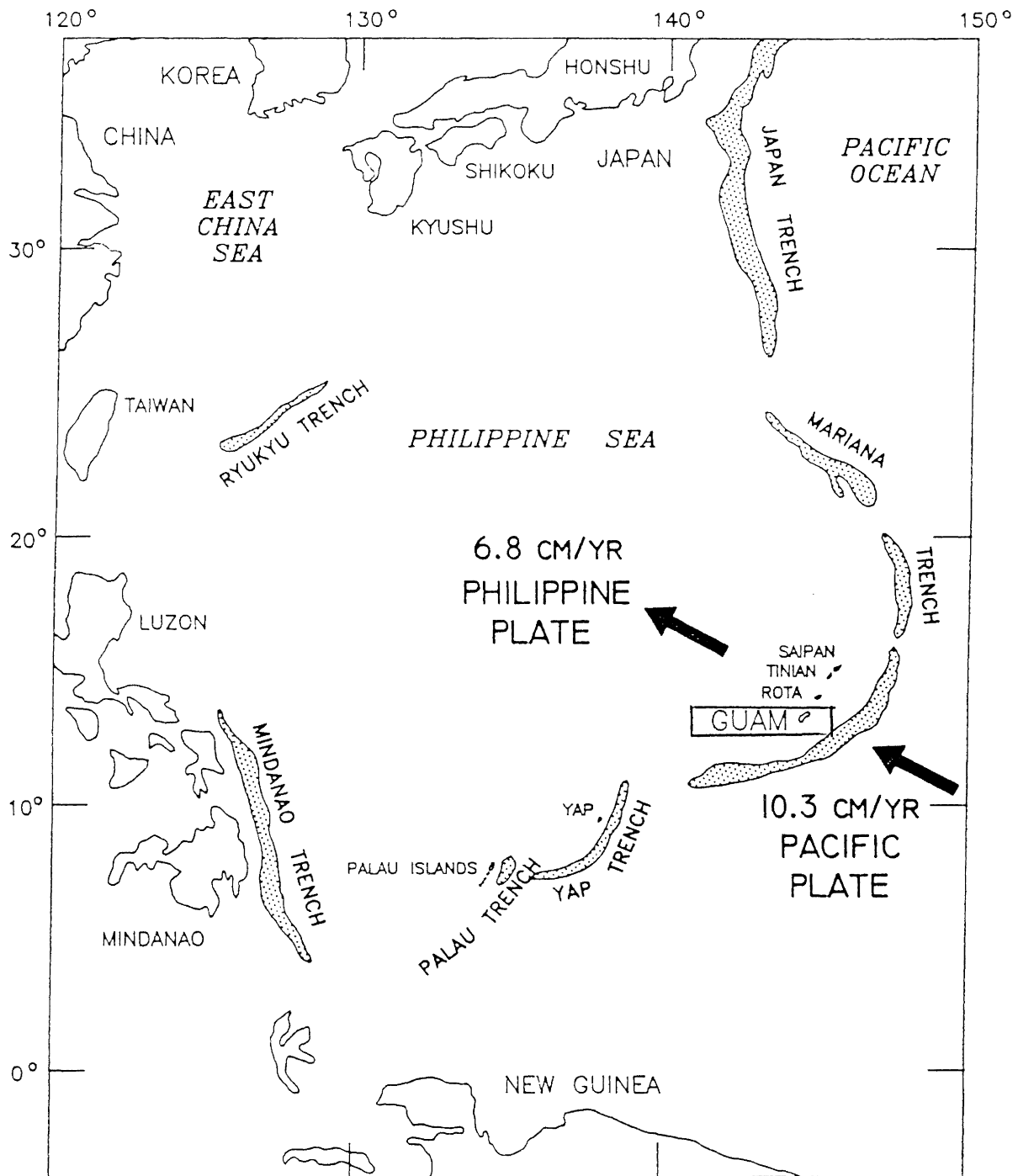
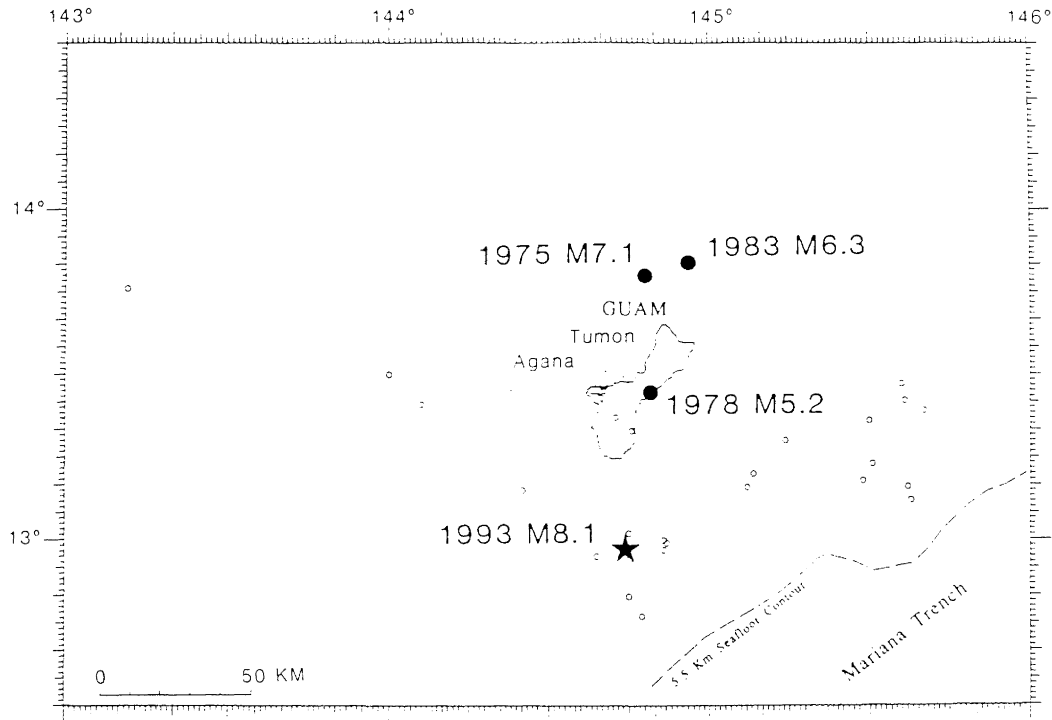

Figure 1 Location and seismotectonic setting of Guam [1]



**Figure 2** Location of main event and aftershocks; and epicentres of notable earthquakes since 1975 [1]

reasonable level of uncertainty associated with the establishment of these distances, and the associated confirmation of the mechanism, which appears to be that of a subduction zone event. EERI [1] note that the most likely fault plane strikes at N70E and dips steeply ( $77^\circ$ ) to the NNW.

The location of the main event and the various minor aftershocks are shown in Figure 2. This figure also indicates the location and magnitude of recent earthquakes on Guam. The last major earthquake to cause significant damage on Guam occurred in 1936 and was of intensity MM VIII.

No significant tsunamis were generated by this earthquake, although wave heights of up to 98 cm were recorded in Japan [1].

No recordings were obtained from the four strong-motion units located on Guam. Three of these accelerographs had not been maintained since 1988, and the one active system operated by the US Geological Survey failed at the time of arrival of the shear wave, possibly due to the loss of contact with the data acquisition unit. The estimated peak ground acceleration of 0.25g was based on observation only.

Where cracking was present in buildings, signs of movements in both principal directions were usually observed. It appears therefore that the earthquake featured two distinct directions of attack, although the absence of strong motion records means that this cannot be confirmed.

#### GEOLOGY OF GUAM AND SUMMARY OF GROUND RESPONSE

The geological structure of the island consists of volcanic rock overlain by a capping of coralline limestone varying in thickness from 50m to 1000m. For the majority of the island, the topsoil layer is very shallow, although reactive clays are present in the south.

The coastline is typically rocky, although there are natural beach areas to the west and limited areas of marine deposits (up to 30m deep), alluvial deposits and swamp (over 30m deep). The natural beach areas feature a shallow layer (3 to 7m) of coarse, medium dense sand.

Of these materials, only the marine and alluvial deposits are considered likely to be susceptible to liquefaction. The sands in the Tumon Bay area where virtually all of the high-rise buildings are located are considered too coarse in grading and too shallow as a layer for liquefaction to occur. It is understood that there were few instances of liquefaction observed, although this could not be confirmed.

Localised slumping and lateral spreading of reclaimed waterfront material by up to 500mm and 200mm respectively was observed in the wharves of both the main port and the US Coastguard station (refer Figure 3). Similar ground displacement affected one of the main power generating facilities adjacent to the port area. It is believed that this ground damage occurred in association with some liquefaction in these areas.



*Figure 3 Lateral spreading of US Coastguard port facilities*

Neither liquefaction nor ground settlement was observed in the locations where damage to the multi-storey hotel buildings occurred.

Local rockslides occurred around near-vertical cut and natural cliff faces, but tended to affect only loosely-cemented or highly weathered rock material. There was only one report of a major new land slippage. No fault scarps associated with this earthquake have been observed, although it is understood that previously active faults have since been located.

Limited slumping of the deep, loosely compacted material of the Agana swamp and alluvial fans of the southeast coast occurred, resulting in vertical and lateral displacement of some roads by up to 50mm. Settlement in excess of this amount occurred to sections of fill to the abutments of road bridges around the southeast coast.

The degree of amplification of base acceleration due to the sands and silts is considered to be much less than that experienced in other recent international earthquakes. The basis for this observation is the uniform response of low-rise buildings and other "indicator" structures throughout the island.

#### **BACKGROUND TO CONSTRUCTION AND SEISMIC DESIGN PROVISIONS ON GUAM**

The structural design of buildings is required to be in accordance with the Uniform Building Code. For seismic design, Zone 3 provisions apply. The design of buildings is however governed by typhoon considerations, with the design wind speed being 155 mph (70 m/s). Along with the historical development of the island, this has meant that the profile of buildings on Guam is strongly skewed towards concrete and concrete masonry of age less than thirty years. No unreinforced masonry buildings were sighted, and only a small number of older timber domestic structures were identified.

The use of structural steel is confined to warehouse buildings, although a recently completed twenty storey resort hotel is understood to contain an eccentrically braced structural steel frame.

Figure 4 shows a typical house, with a near-flat reinforced concrete roof. Most roofs of such structures are concrete, as it is virtually impossible to get insurance for roofs of lightweight construction.

Although the strength design of high rise structures is typically governed by wind forces, they are detailed for ductility in accordance with Zone 3 requirements. There are approximately 30 high-rise buildings on Guam, with only one being greater than twenty storeys in height.

Construction of all types of buildings is predominantly either cast in situ concrete or concrete masonry, or a combination of both. The concrete masonry units used on Guam are very similar to those used in New Zealand in terms of configuration and mechanical properties. Typical reinforcement for masonry walls is D16 vertical bars at 400 centres and D10 horizontal bars at 800 centres. External walls are almost always fully grouted; some internal partition walls are only partially grouted.

Foundations typically consist of spread footings or raft foundations, with some of the taller buildings in the vicinity of the Agana swamp being supported on driven piles.

The location of Guam creates a highly aggressive environment with respect to building durability. A number of concrete structures are showing signs of advanced corrosion of reinforcement, including some of relatively recent vintage. Some dislodgement of concrete from such buildings due to the earthquake was noted.

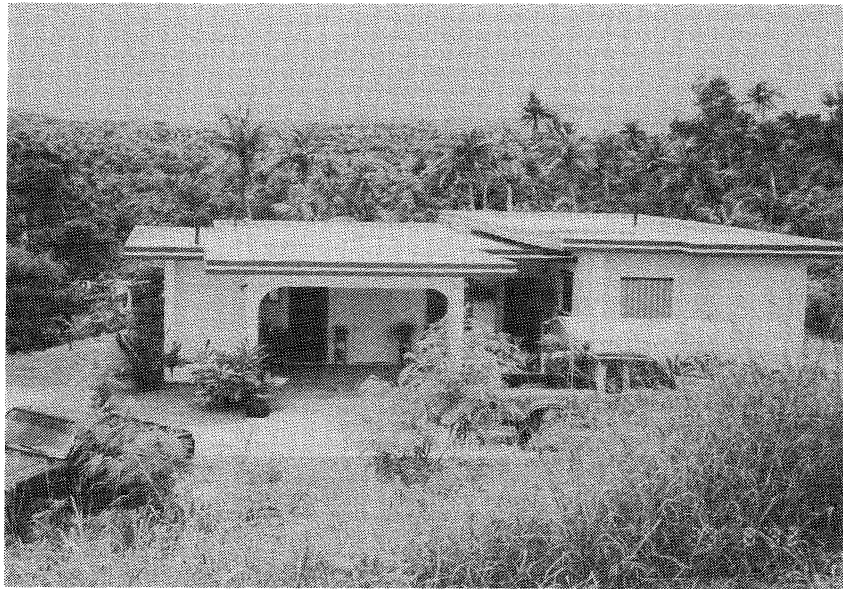

Figure 4 Typical house construction on Guam

## RESPONSE OF BUILDINGS AND OTHER STRUCTURES

### General

Few buildings suffered major structural damage, and the majority of those that did were in the medium- and high-rise categories. The standard one and two-storey dwellings with reinforced concrete masonry walls and concrete floors and roofs sustained very little damage, due to a combination of methods of construction and long period characteristics of the earthquake.

Table 1 summarises both the common types and estimated frequency of structural systems used in buildings on Guam, along with assessed levels of damage (expressed as percent undamaged). In this context, "damage" is considered to include structural and non-structural damage, but not damage to contents. In both cases, the percentages are estimated in terms of numbers of buildings only, noting the highly subjective nature of the table.

As well as further emphasising the near-absence of buildings of light framed construction, this table shows that very little damage occurred to low-rise buildings. The greatest levels of damage involved moment resisting frames, particularly where concrete masonry infill panels had been designed to be separated but were not constructed in accordance with the details.

### Low - Rise Buildings

It is estimated that fewer than 10% of buildings in this category sustained structural damage.

Some significant damage was sustained by low-rise structures of large mass. Buildings featuring long span concrete roofs were the worst affected in this regard, with school auditoria and grandstands being prime examples. Where these heavy mass, long period structures were supported by tall

freestanding columns, significant degradation of concrete at the tops and bottoms of columns was observed. In only one case however did such a canopy collapse; it was a large porte cochere supported by four circular columns which reportedly had a clearly inadequate level of transverse reinforcement.

Some examples of low-rise structures that were damaged by the earthquake are given in the following case studies:

#### Inarajan High School Gymnasium

A view of the interior of this 1973 building is shown in Figure 5, which indicates the massive nature of the concrete roof over the enclosed space of approximately 40 m by 30 m. This roof is approximately 10m above ground level, and is supported only on 600mm by 600mm columns with a perimeter ring beam. The base of one such column is illustrated in Figure 6, showing the very low levels of both longitudinal and transverse reinforcement.

While it is clear that a measure of yielding has occurred at the base of this lightly reinforced column, this was the worst affected element of the 26 columns. The structure as a whole performed appreciably better than the porte cochere referred to above, despite having similar mass to span ratios and equally inadequate transverse reinforcement. The beneficial effect of the improved redundancy of a multi-member system, even if responding in a undesirable mode, is again illustrated.

#### Service Station Canopies

For typhoon reasons, virtually all of the service station canopies on Guam are constructed of concrete, despite being of the same style of architecture internationally. Some of these canopies suffered significant yielding of the tops and bottoms of support columns, as shown in Figures 7 and 8. These service station canopies typically feature a standard design on a company by company basis, and those of certain companies sustained similar levels of

**Table 1: Structural Types and Overall Damage Estimates for Buildings on Guam**

Structural System		Estimated % of total no.	Assessed % Undamaged
Low rise	(three storeys or less)		
	Steel frame with light cladding; steel frame with structural masonry infill; timber frame	< 5%	> 95%
	Reinforced blockwork	30%	90%
	Reinforced concrete	30%	90%
	Reinforced concrete with structural blockwork infill	35%	90%
Medium rise	(four to seven storeys)		
	Steel frame with light cladding; steel frame with structural blockwork infill	< 5%	> 95%
	Reinforced blockwork	5%	> 95%
	Reinforced concrete - walls - moment frames	25% 20%	90% 70%
	Reinforced concrete with structural blockwork infill	50%	70%
High rise	(eight storeys or more)		
	Steel frame (light or separated block cladding)	1 No. only	100%
	Reinforced concrete - walls - moment frames (cladding designed as separated)	60% 40%	70% 60%
	Reinforced concrete with structural blockwork infill	Nil	N/A

damage in the various locations around the island.

Back analysis of the canopy shown in Figure 7 indicated a period of approximately two seconds, which is broadly consistent with the taller of the high-rise buildings that sustained damage.

#### Greyhound Racing Stadium

This grandstand featured two structural sections; firstly a concrete stadium roof on free-standing columns over covered tiered seating, and secondly, a single storey back-of-house section of concrete frames rigidly infilled with concrete masonry blockwork. These sections were

linked only by beams, as the roof diaphragms were offset in level by approximately one metre.

This configuration is shown in Figure 9, along with the damage that occurred to the beams due to the out-of-plane movement. There was no structure linking the two diaphragms other than the minor axis of the roof beams, and the significantly different periods of the two sections generated appreciable forces at this interface.

#### Elevated House on Free-standing Columns

There was only one house viewed that had suffered major structural damage. This two storey house was supported

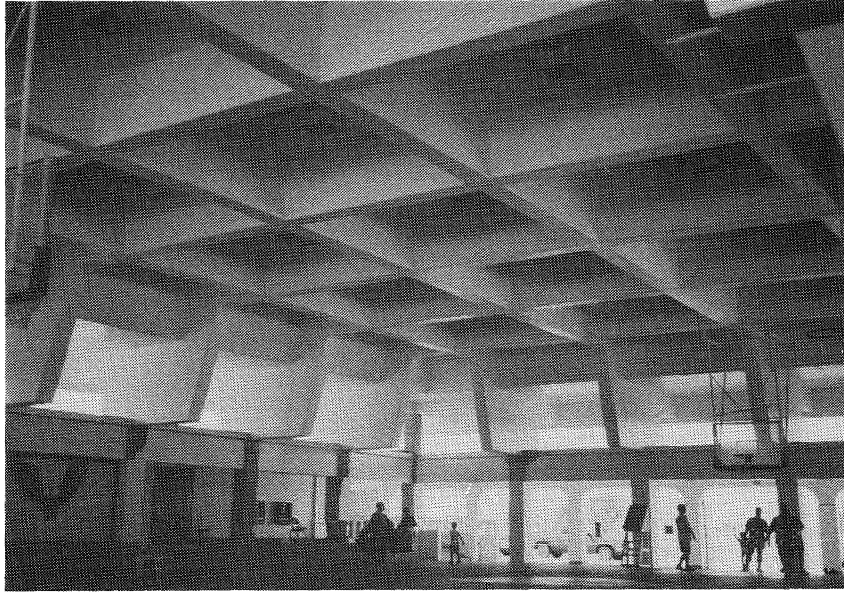

*Figure 5 Inarajan High School - interior of gymnasium showing heavy concrete roof*



*Figure 6 Inarajan High School - base of column supporting gymnasium roof*

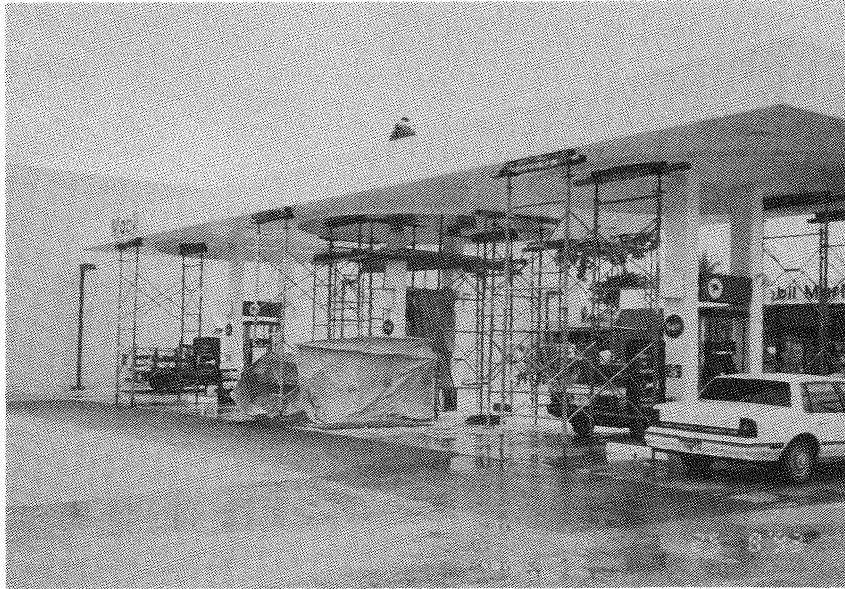

*Figure 7 Concrete canopy to service station*

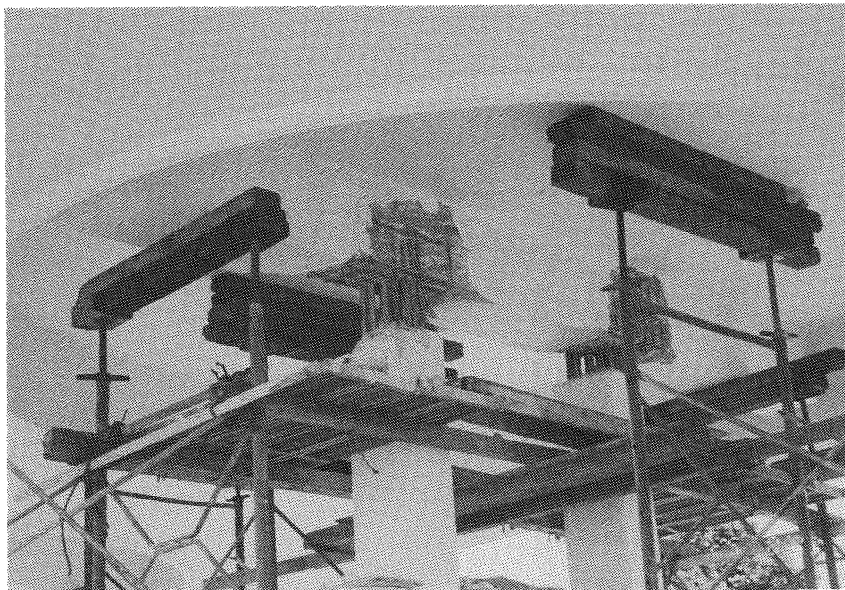

*Figure 8 Crushed concrete removed from tops of columns supporting the concrete canopy*

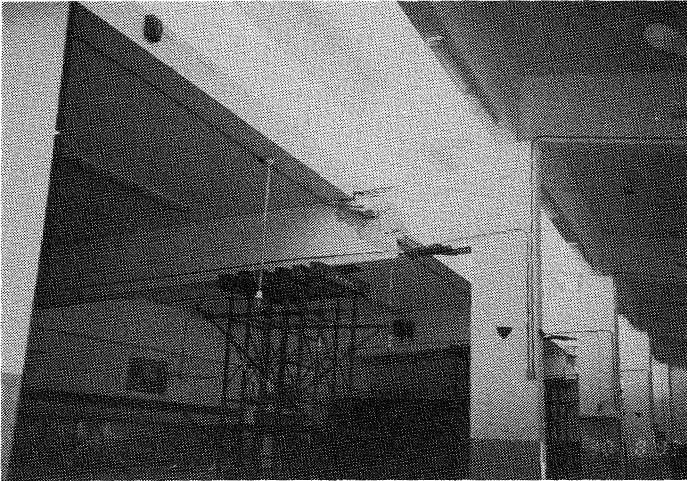

*Figure 9*     *Damage to beams at junction of discontinuous diaphragms to grandstand roof, Greyhound racing track*



*Figure 10*     *House on free-standing columns*

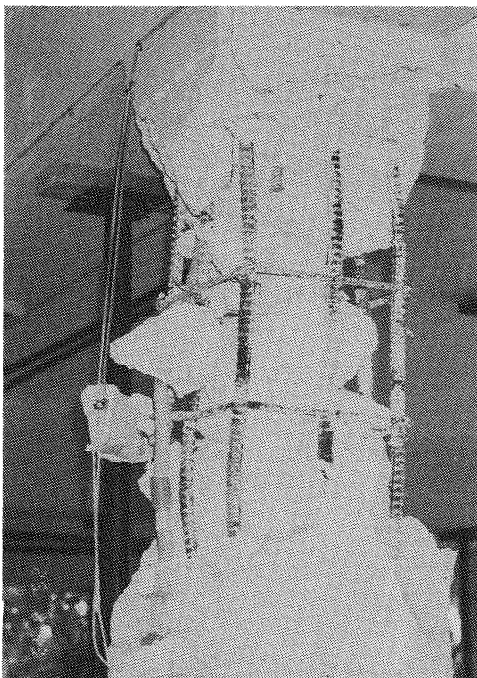

*Figure 11*     *Hinging of tops of columns to house on free-standing columns*



Figure 12 Front of Grand Hotel showing soft storey effects



Figure 13 Severe cracking to coupling beams of Pacific Star Hotel



Figure 14 Minor cracking to coupling beams of the Guam Reef Hotel

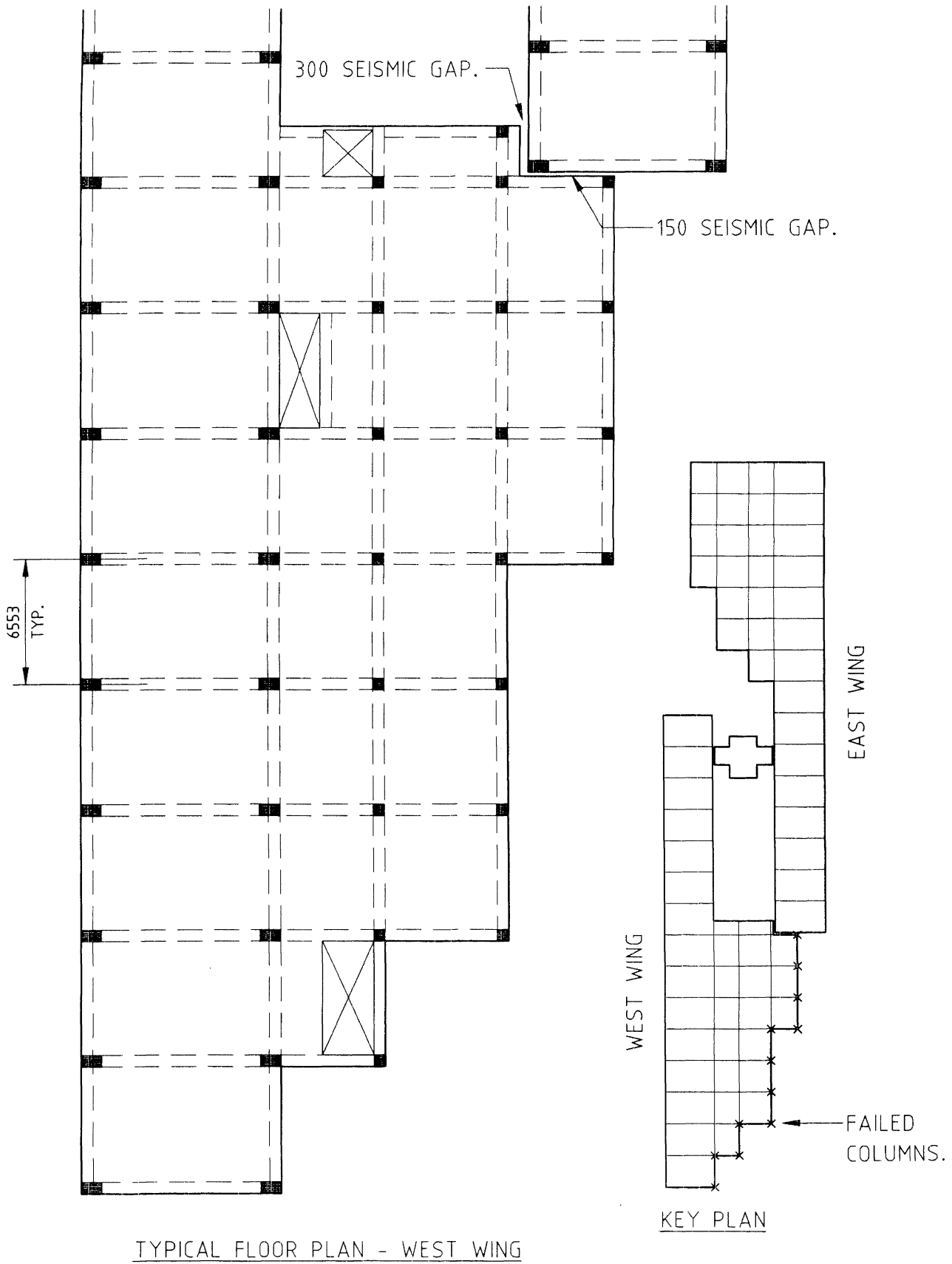

TYPICAL FLOOR PLAN - WEST WING

Figure 15 Plan of Royal Palm Hotel

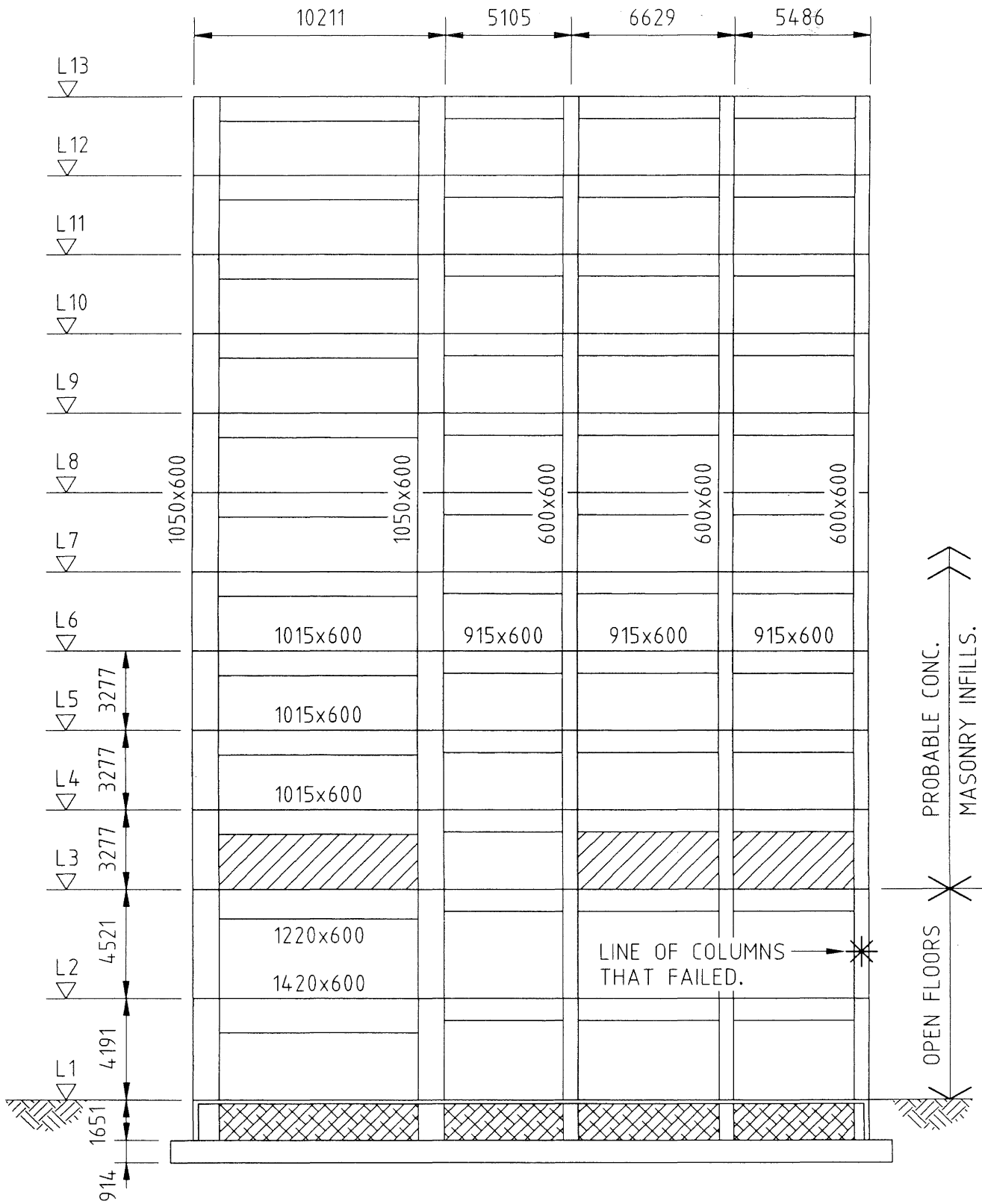

Figure 16 Elevation of typical frame, Royal Palm Hotel

on free-standing 350mm square columns with no bracing in the lower level, which is in marked contrast to the typical method of construction outlined above.

Figure 10 shows the elevation of this dwelling, and the resulting yielding of the tops of the columns to the lower level is illustrated in Figure 11. This level of yielding occurred in the majority of these columns, although it was noteworthy that the house did not have any significant residual out-of-plumbness.

Although very few houses sustained structural damage, there were numerous recorded instances of movement and dislodgement of hot water cylinders.

### Medium - Rise Buildings

Damage levels for buildings in this category were extremely variable. While a number of commercial buildings in this category have areas of spalling in local critical areas, of those that did sustain cracking, in the majority of cases this involved only minor non-structural cracking.

A four-storey hotel building of 1970's vintage appeared to suffer from a ground floor soft-storey failure mechanism due to a combination of poor detailing and highly eccentric layout, and is to be demolished (refer Figure 12).

### High - Rise Buildings

There was significant damage to some buildings in this category, with the Royal Palm Hotel suffering spectacular failure of a number of columns in one wing. In general, however, damage was confined to minor cracking to structural and non-structural elements.

Of the estimated total of 30 high-rise buildings on Guam, 24 were able to be surveyed as a part of this reconnaissance exercise, albeit very briefly. All but four of these buildings are either hotels or apartment buildings. The tallest building on Guam stands at 32 storeys, and sustained minor non-structural damage only.

This survey was based on external inspection only, although the interiors of six were also inspected. Excluding the Royal Palm, this survey indicated a slightly higher level of damage for buildings constructed in the 1970's than for those of more recent vintage. This observation relates mainly to less adequate (and in some cases non-existent) movement allowances in the earlier designs in terms of separations of both infill blockwork elements and buildings. Cracking of infill concrete masonry panels due to inadequate separations for in-plane actions occurred in many multi - storey frame structures.

Inadequate separation or detailing at movement joints of large adjoining structures was also a frequent occurrence, but this in itself did not lead to major problems due to the relatively small overall displacements. Based on observations of non-structural damage, it appears that there was only a limited amount of interstorey drift. This aspect in particular has given rise to this earthquake being described as a serviceability limit state event.

Cracking, and in at least two cases failure, of coupling beams between structural walls was another common damage characteristic in high-rise buildings. Two such examples are shown in Figures 13 and 14, and are taken from buildings

that are less than five years old. In both cases, it is interesting to consider what remedial measures would be most appropriate, given that both of the buildings suffered relatively minor damage otherwise.

In some cases for buildings designed in the 1970's, it appeared that coupling beams had been ignored in the design of wall systems.

The damage sustained by two high-rise buildings is of particular interest, and is described in the following case studies:

#### Royal Palm Hotel

The layout of this recently completed twelve storey moment-resisting frame building is shown in Figures 15 and 16, along with the location of columns that had failed under seismic action in the transverse direction. Inspection of the building was restricted to a brief viewing of the exterior only, and so only those columns that were observed as having failed are marked in the accompanying figures. However subsequent investigations by engineers involved in preparing the building for demolition have revealed that in excess of twenty columns on the south side have failed to varying degrees.

The west and east wings are not connected structurally. While the wings are both somewhat irregular in plan, the building is vertically regular.

Figures 17 to 21 contain photographs showing the nature of the resulting damage. The overall displacement of the top of the west wing was of the order of 2.4m.

Both wings were demolished in December. The less damaged east wing was demolished as a consequence of both the loads imposed by the west wing bearing against it and remaining concerns about the design and construction integrity of it.

This building was designed in accordance with the 1988 version of the Uniform Building Code, with the frames being designed and detailed as special moment resisting reinforced concrete frames. Response spectrum analysis was used as the basis for design, with an equivalent ground acceleration of 7.5% of gravity being used to match the UBC base shear requirement. However, wind load governed the strength design of members, with the designer noting in the design brief that for the majority of members, the strength provided was approximately four times that required for earthquake loading considerations. While this statement would suggest an unsatisfactory hierarchy for earthquake forces at the ultimate limit state, it is unlikely that this level of force was in fact generated.

The primary mode of failure of columns at second storey level appears to have been crushing of concrete in the mid-height regions, which in turn led to failure of the joints of adjacent columns (refer Figure 19). The cause of this failure is not readily apparent, and appears to be due to a combination of factors.

Structural drawings of the hotel were inspected, and dimensions of one of the failed frames are reproduced in Figure 16. Reinforcement details for two of the most common column types are shown in Figure 22.



Figure 17    *Damage to west wing, Royal Palm Hotel*

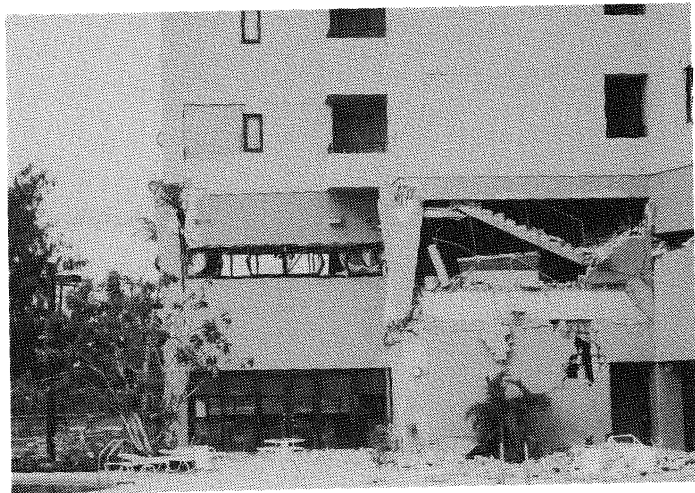

Figure 18    *Damage to west wing, Royal Palm Hotel*

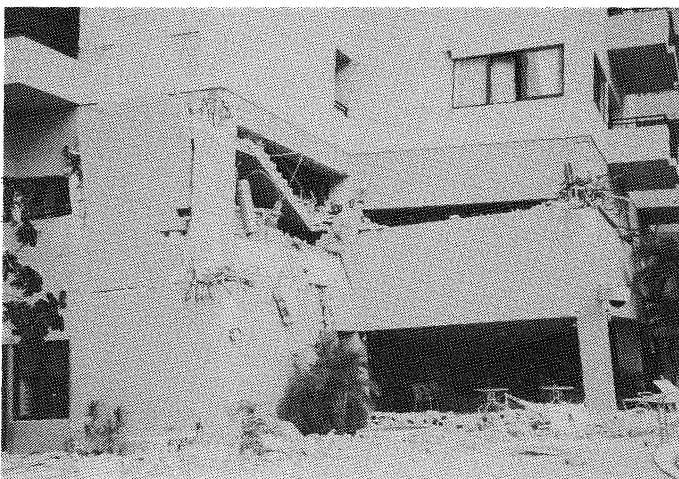
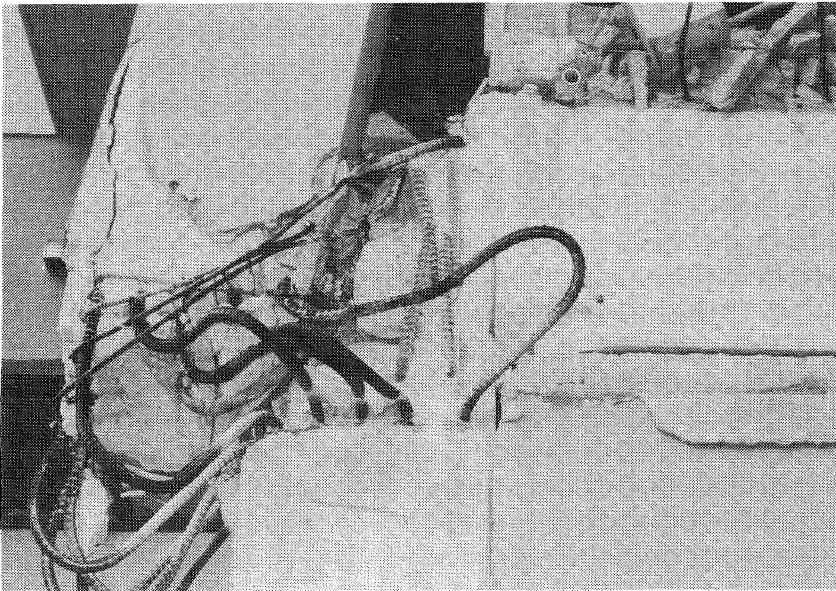

Figure 19    *Damage to west wing, Royal Palm Hotel*

Back analysis of the typical frame shown in Figure 16 indicated that there was no obvious inadequacy in the design. Relatively moderate levels of axial load were calculated to be induced in the columns that failed, even under lateral forces approaching that of the wind load case. There appears to be less transverse reinforcement in the end regions of the 600 mm x 600 mm columns than required by the UBC, and less than would be required by the New Zealand Concrete Code, NZS 3101. However, the transverse reinforcement in the mid-height regions, where failure appears to have initiated, is in accordance with the less onerous provisions for these regions of both the UBC and NZS 3101.

Whether all of this reinforcement was present in the columns is however less certain. The joint illustrated in Figure 20 and the middle region of the column shown in Figure 21 would appear to suggest otherwise.

Another significant factor is the presence of concrete masonry partition walls between the hotel rooms in the levels above the point of failure. It appears that these walls are located on column lines, and it is believed that there was negligible separation between these wall elements and the framing members. The drawings called up 12mm and 25mm separations around the vertical and beam soffit junctions respectively for all masonry infill



*Figure 20*    *Damage to west wing, Royal Palm Hotel*

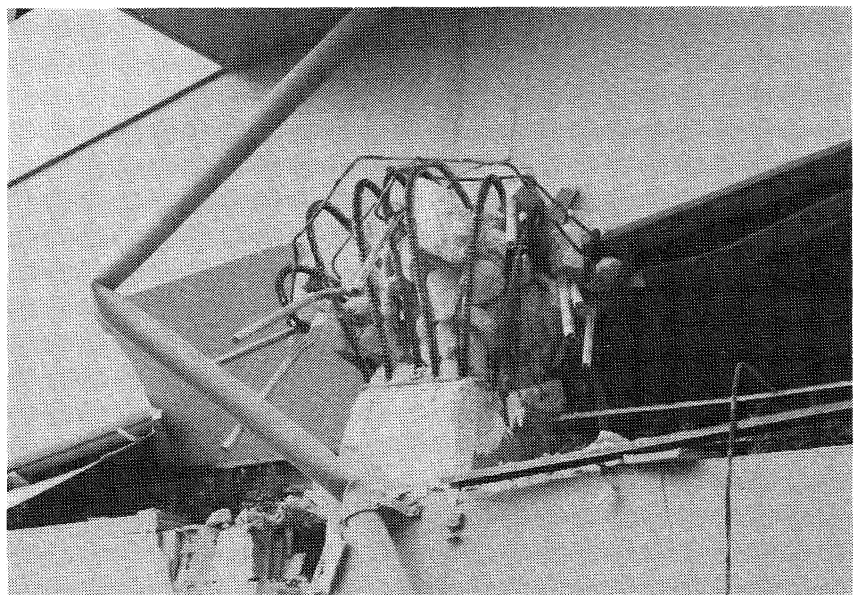

*Figure 21*    *Damage to west wing, Royal Palm Hotel*

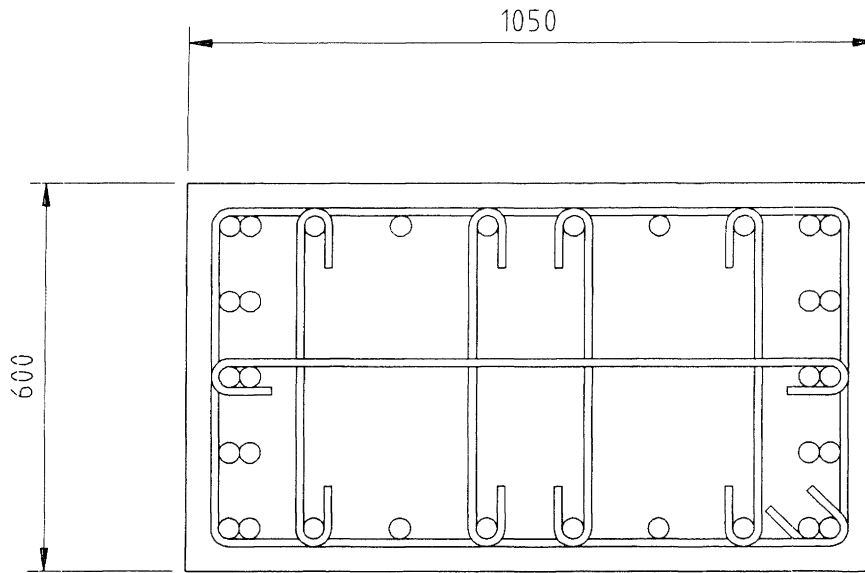

UP TO LEVEL 3 :

32-HD28  $f'_c = 28\text{MPa}$   
 R16-100 END REGIONS  
 R16-125 MIDDLE REGIONS  
 R12-100 JOINTS

ABOVE LEVEL 3 :

16-HD28  $f'_c = 28\text{MPa}$   
 R16-100 END REGIONS  
 R16-175 MIDDLE REGIONS  
 R12-100 JOINTS

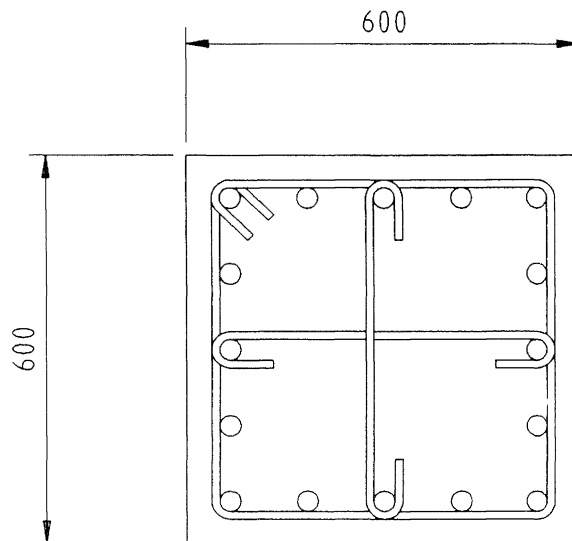

16-HD28  $f'_c = 28\text{MPa}$   
 R12-100 END REGIONS  
 R12-300 MIDDLE REGIONS  
 R12-100 JOINTS

Figure 22 Reinforcement details for columns, Royal Palm Hotel



Figure 23 Damage to masonry infill panels, Royal Palm Hotel

walls, but these gaps were not observed to be present in the exterior infill panels. Other as-constructed details associated with these infill panels were different to those shown on the drawings.

Typical damage sustained by the non-structural masonry panels of both wings of this building are shown in Figures 23 and 24. The cracking shown in Figure 23 resulted from movement in the longitudinal direction, which in combination with the failure of the west wing due to transverse actions, illustrates the different directions of earthquake attack experienced by buildings on the island.

Figure 24 shows the damage to the east wall of the east wing. This type of cracking to block infill panels can be considered typical of what might occur in frame structures with inadequate separations in New Zealand in a serviceability limit state earthquake. The cost of repairing and reinstating this type of damage is not inconsiderable, particularly when due regard is given to the effect on interior finishes and fittings.

#### Holiday Inn Hotel

This building is still under construction (refer Figure 25), with work having stopped in 1991 due to funding difficulties. Five levels of this eleven storey frame structure had been completed prior to this halt, with the framing for the lightweight-walled service core having been continued for an additional three storeys (Figure 26).

While there were few signs of movement in the main (lower) structure, the core framing had clearly been excited by the earthquake. Figure 27 shows compression bar buckling that occurred in one of the beams one level above the last full floor. Similar signs of yielding were in evidence at other locations on this level, as illustrated in Figure 28.



Figure 24 Damage to masonry infill panels, Royal Palm Hotel

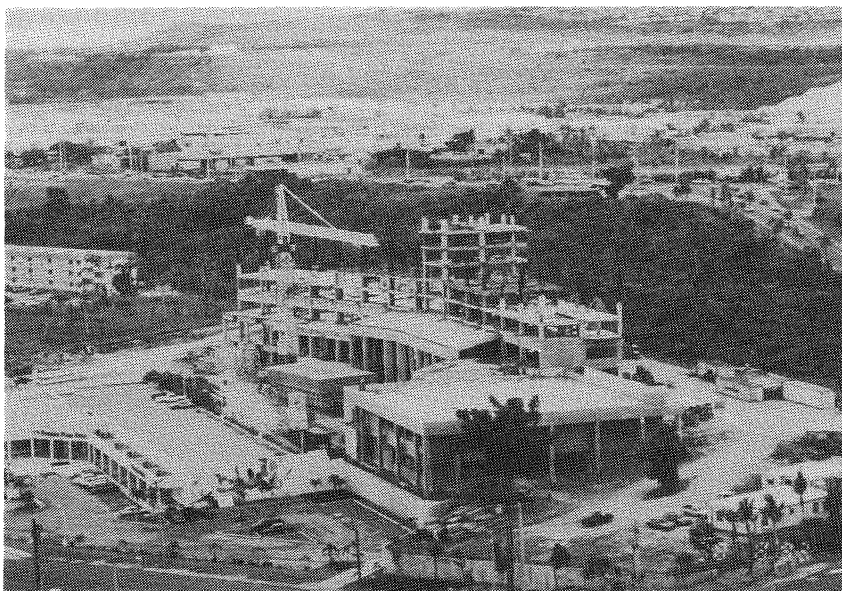

Figure 25 *Holiday Inn Hotel*

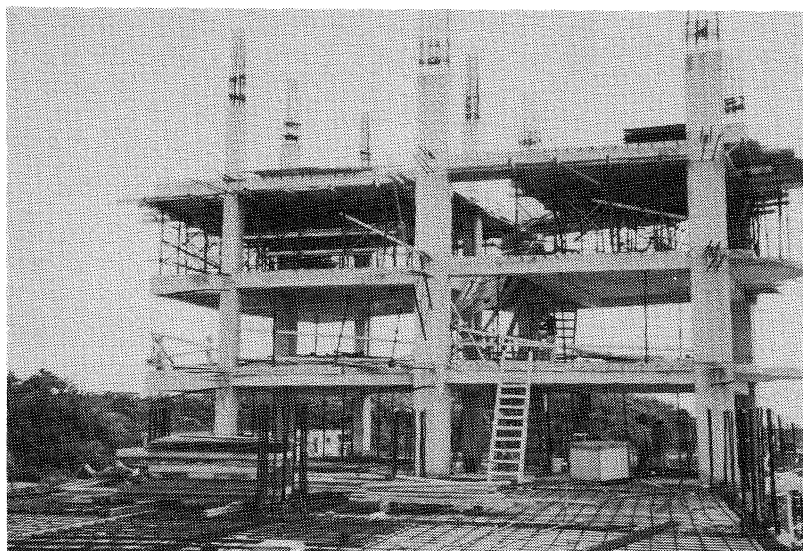

Figure 26 *Service core, Holiday Inn Hotel*

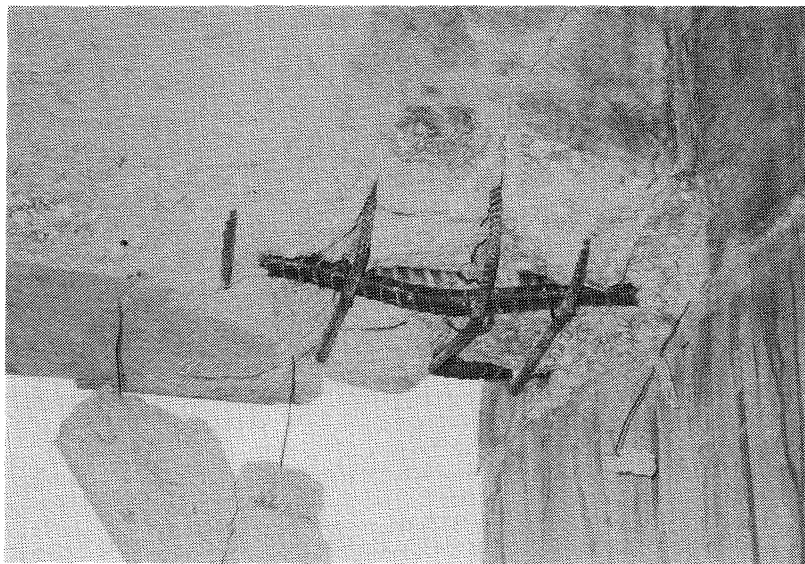
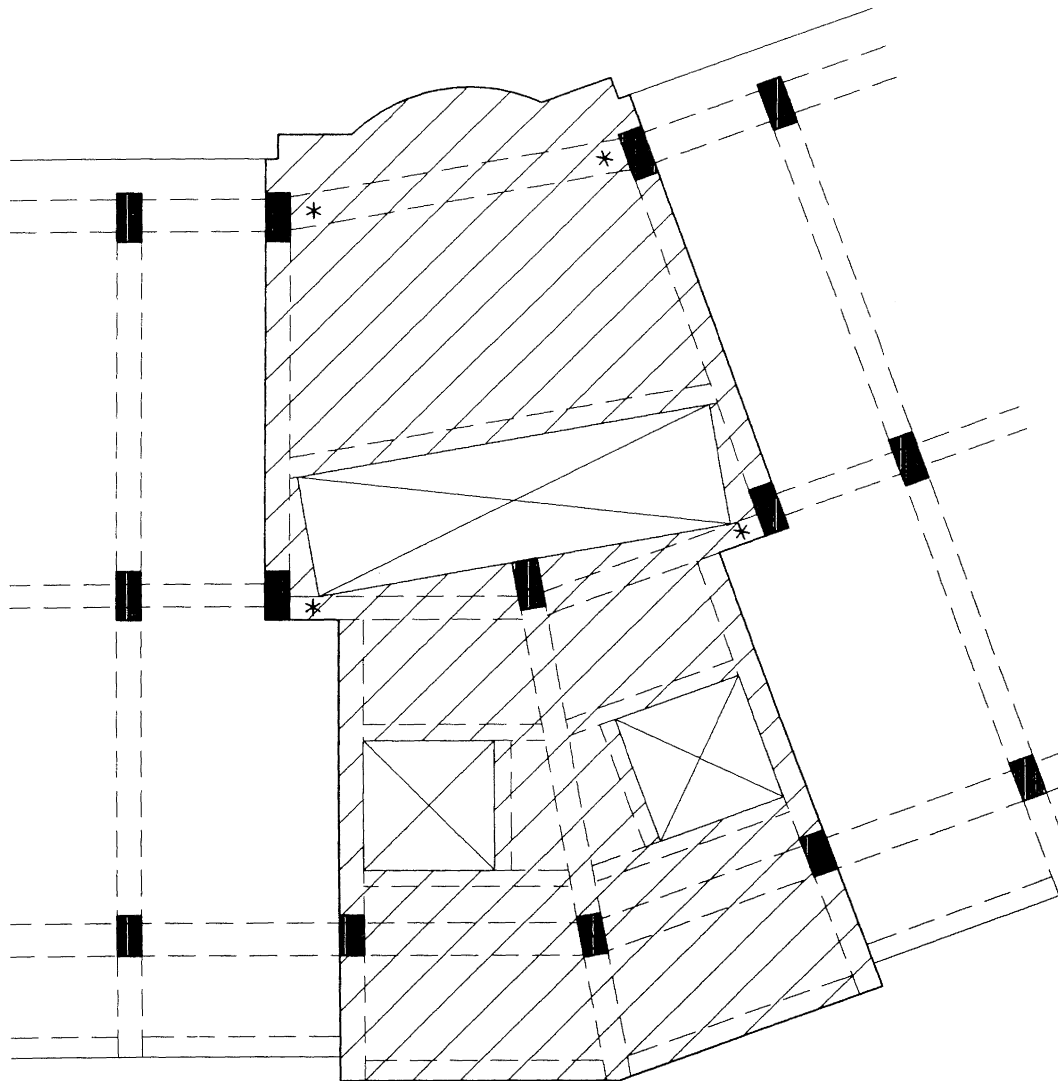

Figure 27 *Yielding in beam, Holiday Inn Hotel*



\* DENOTES LOCATIONS WHERE  
YIELDING OF BEAMS OCCURRED.

TYPICAL CORE PLAN

*Figure 28 Plan of service core, Holiday Inn Hotel*

The occurrence of this yielding is somewhat surprising, as there is relatively little mass in the advanced core. The beam bar in Figure 27 is however approximately 50mm in from the 90° bend of the stirrup, and this again shows graphically the vulnerability of untied bars in compression.

The occurrence of this damage to a bare frame raises questions about the amount of work involved in inspecting buildings following a serviceability limit state event. For a completed frame building, there would be a considerable amount of effort and disruption involved just in lifting carpets and ceiling tiles in order to establish the level of damage sustained to key members.

#### **Non-Structural Elements and Building Services**

As would be expected, there was considerable damage to non-structural elements, over and above the problems with concrete block infill panels noted earlier. Common elements affected include:

- . Ceilings - suspended systems are typically not braced and tiles not clipped in, and so a large number of tiles in the upper levels of the taller buildings were dislodged. It should however be noted that in most cases tiles consist of lightweight fibreboard or softboard materials, and do not

pose the level of safety hazard that heavier acoustic tiles do.

#### . Plant and Equipment

- there did not appear to be consistent damage to plant and equipment in the taller buildings. A detailed survey of this aspect was not possible due to the reluctance of hotel operators to permit inspections. However for the hotels where evacuation was not required, it is understood that the majority of facilities were promptly re-activated under standby power.
- significant movement and failure of the nominal restraints in some roof-mounted plant was however observed, and it was clear that such connections had not been the subject of any seismic design input.
- few sprinkler pipes were fractured or activated by the earthquake, presumably due to the limited amount of movement experienced by most buildings. However some fracturing did occur where sprinkler and water supply pipes crossed movement joints between hotel wings.

#### . Tiles and finishes

- some of the newer hotels experienced significant loss of bathroom and hallway tiles and finishes. It is understood that the cost of damage to marble facings was significant for several of these hotels. The same problem did not seem to occur to the same extent in the older hotels of similar standard.

Apart from this, damage to non-structural elements (other than infill panels) was not widespread in the high-rise buildings inspected. It is understood that loss of glass was only reported in the two hotels that reached a collapse state, noting that there is not widespread use of either curtain walling or feature glazing due to the ever - present threat of typhoon attack.

In many instances, however, the cracking of structural elements had led to the subsequent entry of appreciable amounts of rainwater, and this was posing a considerable problem to repair.

#### Other Structures

A 50m tall by 12m diameter cement silo situated in the port reclamation area sustained moderately severe cracking to its 600mm thick wall.

### RESPONSE OF LIFELINES

The elements comprising the lifelines of Guam are in contrasting states of original specification and condition. Due to the limited amount of ground damage, however, lifeline systems generally were not significantly affected by the earthquake.

#### Power

The oil-fired power system is at the limit of its current

capacity pending the completion of new generation facilities, and non-earthquake related outages are frequent. As a consequence, the use of standby generators is common, and so the relatively brief disruption to the power supply caused by the earthquake did not create many problems.

The most significant post-earthquake problem for the power system resulted from the disturbance of loose asbestos fibres as a result of the toppling of some switchgear cabinets. Repairs to the cabinets were not able to be commenced until the asbestos hazard was removed, and this process took a week after the earthquake. Despite this difficulty, power was restored to 80% of homes and businesses within three days.

#### Water Supply

Potable water is extracted from 92 deep wells located around the island, and stored in 30 steel on-ground reservoirs. Reticulation mains are ductile iron (pressure) and cast iron and asbestos cement (gravity). It is understood that a number of the asbestos cement pipes are showing signs of ageing.

The water supply system sustained some breakage to asbestos cement gravity supply lines, typically at bridges, but this did not cause major disruption. The initial disruption resulted from loss of power to pump the water to the reservoirs, and there were no standby facilities. The reservoirs were typically 30m in diameter, and did not suffer structural damage. The extent of the damage to the mains is likely to take many months to determine, and leak detection programmes are underway.

#### Telecommunications

In contrast to the power system, the telecommunication network on Guam is well-developed as a consequence of its strategic location and function for the US Navy and Airforce. An extensive network of fibre-optic cabling had recently been installed, and few problems in terms of either function or capacity were encountered.

#### Sewerage

Sewerage is pumped through mains to primary screening plants, and discharged to sea via ocean outfalls. Despite once again the lack of standby generators, there was no significant disruption or overflow.

#### Roading and Bridges

Roading ranges from sections of six-lanes of good quality highway on the west (main) side of the island through to narrow, uneven roads on the more remote southeast area. There is only a small number of single, two and three span bridges on Guam, the majority of which are in the latter area.

Roads sustained only minor damage, with some settlement of filled sections of roadway in addition to abutment fill as noted earlier. The EERI estimated that one half of the bridges on Guam sustained some form of damage, but that this was typically minor in nature. The displacement of several bridges led to the rupturing of supported water supply lines, the joints of which were not detailed to accommodate seismic movement.

### Port Facilities

The port was significantly affected by the lateral spreading and slumping of its main container apron. While the container crane runway itself was supported on piles, sufficient movement-induced damage occurred to necessitate a full inspection of the pile tops, and in some cases local repairs.

The port was rendered inoperative for three weeks after the earthquake, and this had a serious effect on the supply of food and other items to the island. It is understood that repair costs in the range US\$8 to 10 million are envisaged for this facility alone.

### RESPONSE FOLLOWING THE EARTHQUAKE

The response to the earthquake by agencies and individuals was rapid and positive in nature. The Civil Defence response plan is similar to that used for typhoons, and there is typically at least one major typhoon every year which disrupts the usual pattern of life on Guam.

As a consequence, there is no complacency on the part of people and organisations on Guam, and the concept of having a response plan is familiar, and the details and procedures are well-practised.

### CONCLUSIONS AND RECOMMENDATIONS

In terms of the potential of a magnitude 8.1 earthquake to cause damage, this was not a sizeable event. Notwithstanding this, it was very thought-provoking to see just how much damage did result to some structures from what was effectively only a moderate earthquake.

It was of particular interest to view the performance of the earlier high-rise buildings (ie. early and mid-1970's). The nature of their performance under this level of lateral force was not markedly worse than for the more modern structures, although less generous (sometimes non-existent) building and element separations led to greater damage from the interaction of components. The issue of inadequate separations was offset to some extent by the less adventurous architecture of the earlier buildings, which seemed to result in more straightforward load paths.

Our current efforts towards gaining a better understanding of the behaviour of early reinforced concrete and structural steel buildings certainly appear justified.

Recommendations arising from the observation of this earthquake include:

- Structural designers need to convey more clearly to owners and insurers the aims implicit in current design approaches. That is, safety is the first priority, followed by the restriction of damage in moderate earthquakes. The uncertainties associated with designing for damage control need to be highlighted, in contrast to the good level of confidence in satisfying the primary objective of safety. This earthquake has underlined the unpredictability and variability of building responses at low levels of seismic load.

- There needs to be a more focussed approach to Quality Assurance in terms of the communication interface between structural designers and constructors. In addition to the necessary general checking and traceability associated with Quality Assurance, it is suggested that designers should separately and deliberately identify for the builder the critical structural elements that require particular care in construction. In this context, the term "structural element" includes connections to and separation from non-structural elements.

- There would be benefits from formulating in advance an outline strategy for carrying out repairs to the types of damage that would result from a moderate earthquake in New Zealand. It is the regulatory aspects of this issue that give rise to the greatest concern, noting that in terms of the Building Act, a structure damaged in an earthquake would only need to be repaired or reinstated to the level of strength or performance that it had previously. This has particular implications for older structures designed to earlier codes.

Overall, the opinion was formed that for high-rise structures, this earthquake represented a serviceability limit state event (ie. one that could occur more than once during the lifetime of a structure). Observing the response of these structures to such an event, along with the issues that arose, was the principal benefit of this reconnaissance visit. Some of the key observations outlined above are less apparent from earthquakes that are more damaging and involve older and more susceptible forms of construction.

It is considered that the financial effect of a moderate earthquake such as experienced by Guam on a major metropolitan centre in New Zealand would be much greater than is generally envisaged.

### ACKNOWLEDGEMENT

Figures 1 and 2 are taken from Comartin et al [1] (see reference below) and are reprinted by permission of the Earthquake Engineering Research Institute (EERI).

### REFERENCE

1. Comartin C., et al, "The Guam Earthquake of August 8, 1993", EERI Special Earthquake Report, EERI Newsletter, October 1993.