

SEISMIC DESIGN OF BRIDGES

SECTION 7

SMALL BRIDGES

R.W. Fisher*, A.G. Lanigan**, M.J. Stockwell***

7.0 NOTATION:

$C_{H\mu}$	=	Basic horizontal seismic coefficient.
$C_{H\mu}(T=0)$	=	Basic horizontal seismic coefficient for period $T = 0$ seconds.
H	=	Seismic base shear force
T	=	Fundamental natural period of structure
μ	=	Structure ductility factor

7.1 INTRODUCTION:

Although procedures for assessing design loading are given, the prime consideration for design should involve the selection of sound structural form and careful detailing. At the lower end of the small bridge range and for small box culverts, it is envisaged that attention to good detailing will by itself provide all that is necessary for adequate seismic resistance. As bridge size, or design complexity increases, then the need for some form of seismic analysis assumes more importance. The designers judgement in these matters must remain a critical aspect of small bridge design.

7.2 OBJECTIVE AND DEFINITION:

The objective for small bridges is to introduce seismic design concepts which are suitable for application within limited resource design offices and which provide a similar standard of protection to that required for larger structures.

For the purposes of seismic design it is difficult to specify the upper limit of small bridges or to place them in definitive categories and experienced engineering judgement will be necessary in deciding the limits of application for the design procedures in this section.

7.3 DESIGN STANDARDS:

There is a greater total investment in the small size bridges group than in the larger structures. When occurring on important highway or rail links, earth-

-
- * Assistant Bridge Engineer, Chief Civil Engineers Office, NZR, Wellington
 ** Consulting Engineer, Babbage Partners, Auckland
 *** Christchurch City Council

quake damage to a number of small bridges could well be collectively significant in terms of public safety, disruption to vital traffic and economics of reinstatement.

For these reasons it is desirable to adopt where possible a similar design philosophy and standard of protection to that used for the larger structures.

7.4 DESIGN CONCEPTS:

The nature of many small bridges is such that their interaction with surrounding soils (such as at abutments) dominates or significantly modifies their seismic response compared with that of an equivalent freely vibrating structure. As a simplified concept many bridges of short length can be visualised as being "locked into" the approach embankments during seismic activity. For this reason it may be difficult to correctly model the structures likely behaviour using conventional seismic analysis.

Because of the expected soil interaction dominance with all the associated uncertainties, excessive emphasis on the calculation of appropriate seismic loading is not recommended. Instead, design concepts for small bridges need to place heavy reliance on sound detailing.

In general the design approach described in 7.5 of this section should be used for small bridges. However where this approach precludes desired refinements in structural proportions and detailing, then a more comprehensive analysis may be carried out in order to achieve this.

An alternative in certain suitable cases, the use of energy dissipators may be considered (see clause 7.6)

7.5 DESIGN APPROACH : ASSUMED DUCTILITY VALUES WITH SPECIAL EMPHASIS ON DETAILING:

7.5.1 General -

For the purposes of "small" bridges considered under this clause the following should apply:

- (1) The structure should be designed to resist a seismic base shear, using the procedures given in Section 2.
- (2) Each structure should be allocated an assumed ductility factor according to its primary mode of seismic resistance as defined in 7.5.2.

(3) Except where the primary mode of resistance is as described under (4) below, the basic seismic coefficient should be obtained by using the calculated structure period. No allowance need be made for foundation flexibility unless seismic displacements are required to be calculated.

(4) Where the mode of resistance is provided by (a) friction slabs (b) passive soil resistance at the abutments or (c) tie back systems at the bridge ends such as "dead man" or soil anchors then the basic seismic coefficient should be obtained by taking the structure period as zero i.e. $C_{H\mu}(T=0)$. In the cases of (a), (b) and (c) above, a safety factor of 1.5 on assessed soil strengths should be used in conjunction with the seismic base shear force (H).

(5) Where applicable, the earth pressure component of earthquake effect should be allowed for in addition to the structure inertia forces.

7.5.2 Ductility Values -

Following are the structure ductility categories to be assumed for design.

- $\mu = 6$ Provision of energy dissipation by moment resisting column type pier shafts which will hinge above ground or water level.
- $\mu = 4$ Energy dissipation by foundation hinging below ground, where hinge zone will be reasonably accessible.
- $\mu = 3$ Energy dissipation by:
 - (a) Foundation hinging below water or ground level but hinge zone in inaccessible location.
 - (b) Non-yielding wall type piers on footings.
- $\mu = 2$ Piers with raked piles where there is no provision for hinging to occur in the pier.

7.5.3 Detailing -

The "assumed ductility" design approach requires attention to details in order to avoid potential collapse situations and to facilitate repairs after earthquake damage.

The minimum requirements for ductility detailing as defined in ref.7.5 should apply.

Foundations should receive special consideration. In order to provide for the inevitable situations where piles hinge (whether by choice or accident) it is advisable to select a pile type which

has the best possible deformation characteristics. It is considered that concrete piles detailed for ductility and having substantial shear strength throughout their length, would fulfill the requirements of these situations. Steel section piles would be deemed to have the necessary ductility capabilities.

7.6 ENERGY DISSIPATORS:

In cases where it is economically justifiable and in zones of high seismicity the use of energy dissipating devices may be considered for bridges having stiff sub-structures. The requirements of section 6 should be complied with.

7.7 OTHER CONSIDERATIONS:

7.7.1 Plastic Hinge Location -

Notwithstanding the situations described in 7.5.3 every effort should be made to locate potential plastic hinges above ground or water level. In all instances care is required in order to preclude the occurrence of damage in critical structural members. Capacity design procedures are required.

7.7.2 Integrity of Span to Pier Connections -

Because many small bridges will have simply supported spans the provision of positive span to pier connections will usually be an important design consideration.

Span to pier connections should have sufficient shear strength to satisfy the "Capacity Design" principles as described in Section 3. Where there is difficulty in fully achieving this, then a second line of defence such as providing additional pier top width for span seating should be considered.

7.7.3 Design Ground Levels -

Due to ground level variations, pier stiffness may be somewhat uncertain. It is possible that in time, the ground level may change around the piers of certain bridges. This is particularly likely in the case of river crossings. In such instances, it is possible that initially assumed design response characteristics of the structure may alter significantly. Conservative allowance should be made for this contingency when shear distribution among piers is being evaluated.

7.8 CULVERTS AND VERY SMALL SINGLE SPAN BRIDGES

As stated in 7.4 the seismic behaviour of many types of smaller bridges would be dominated by interaction with the supporting soil. Culverts and small single span bridges can be included in this category.

Detailing to improve structural resistance to ground deformation is of importance. The arrangement of corner

reinforcement in culvert barrels, the connection of all parts, such as wing walls, headwalls etc., to the main barrel and the provision of adequate longitudinal reinforcement (or tying) to resist differential settlements and longitudinal separation, all require attention in culvert design. For large reinforced concrete box culverts and underground pedestrian subways, the design principles described in section 9 should be applied.

In the case of small culverts and small single span bridges, it is considered that seismic design should consist almost entirely of sound detailing.

Corrugated metal culverts are flexible conduits and as such are entirely dependent upon their ability to deform in accordance with the surrounding soil. The only design recommendations which could be made in these cases is that the use or otherwise of this type of culvert should be considered in the light of the likely supporting soil deformations under seismic action and the consequences of possible failure.

COMMENTARY:

C7.5 DESIGN APPROACH : ASSUMED DUCTILITY VALUES WITH SPECIAL EMPHASIS ON DETAILING:

Ductility Values (refer 7.5.2)

The chosen ductility values represent an attempt to categorise some of the more common types of structure in terms of seismic response and serviceability. Background investigation has indicated that the response of a column hinging pier having ductility reinforcement in accordance with DZ3101 may generally be satisfactorily represented by assuming a fixed base and $\mu = 6$. Although the above assumption has been demonstrated to apply only to piers having periods of 0.3 secs. or greater it is considered that in practice most cases will not be affected by this restriction, i.e. where structures have shorter fixed base periods than 0.3 secs. it is usually found that member sizes are governed by practical rather than seismic considerations.

In part, the chosen ductility factors for the remaining structure categories reflect a penalty for undesirable or uncertain energy dissipating mechanisms, rather than entirely indicating the expected response; e.g. imposing a higher design base shear on substructures which hinge below ground or water level will minimise seismic damage in inaccessible hinge zones.

It is considered that in cases where seismic resistance is being provided by piers or abutments alone, (i.e. without the assistance of passive soil resistance), it would be unnecessary to design for a ductility factor of less than 2 as most structures should be capable of providing this measure of ductility. Soil inter-

action effects such as plastic deformation of foundation material and rocking will contribute some measure of energy dissipation in the majority of the least ductile structures.

Rocking Foundations (refer 7.5.2)

References 7.1 and 7.2 indicate that seismic protection can be achieved with "rocking" footings. For small bridges, it is considered that in the absence of a "rocking pier" analysis, non-yielding piers on footings may be assumed to have an equivalent structure ductility of 3.

A similar principle of protection could perhaps be argued for pile foundations. However, in this case, there are recognisable difficulties with the prediction of force levels necessary to induce the energy dissipating "pumping action". This action when occurring within controlled limits in piled foundations would probably provide some secondary benefits, but in these cases it is not recommended that it be used as the principal design means for dissipating energy.

Raked Piles (refer 7.5.2)

There have been reports of unfavourable seismic behaviour with substructures incorporating heavily raked piles. Due to the largely axial resolution of horizontal forces, this type of structure will tend to have low ductility; hence the recommended $\mu = 2$. However, where provision is made for hinging in a pier stem above the raked pile foundation, then a reduced response would be achieved. Also in cases where the rake is only slight, a predominantly flexural type response similar to vertical piles could probably be obtained.

Propped Superstructure Between Abutments (refer 7.5.1)

Where there is negligible clearance separating abutment walls from the superstructure, bridge structures will tend to interact with the approach embankments during seismic activity. In such cases provided slump failure of the approach embankments is unlikely, then passive soil restraint at the abutments may be considered a satisfactory form of longitudinal resistance for bridges of short length.

Where relatively intimate contact between superstructure, abutment and approach embankment exist, then the seismic energy input from both embankment and foundations in combination with passive restraint through an opposing abutment, could cause complexities in structural response. In the case of rail bridges, the rails would introduce further complications. Also there would be some difficulty in accurately assessing the strength and stiffness of the soil behind the abutments.

Nevertheless, although the actual seismic behaviour in these cases would be

difficult to assess theoretically, small bridges of the type which inherently interact with their approach embankments, have quite often satisfactorily survived previous earthquakes. This satisfactory performance has occurred where approach embankments have not slumped severely (thus maintaining longitudinal bridge stability) and where general detailing has been sound. It is unlikely that this type of structure would have in the past been subjected to much more than nominal only seismic design treatment.

For the purposes of introducing a reasonable design method for obtaining structure inertia forces it is to be assumed that bridges which are "locked into" the approach embankments will respond seismically as "rigid" structures. As such it may be further assumed that where passive soil resistance is allowed for at the abutments then the basic seismic coefficient may be obtained by using a period of zero seconds. To prevent possible excessive movement which may damage certain structural parts and to allow for possible soil property uncertainties a safety factor of 1.5 is specified on the assessed passive soil strength.

The earth pressure component of earthquake effects must be allowed for in addition to the structure inertia forces.

Where this mode of resistance is to be relief upon, a wedge of selected granular soil will need to be specified for placing immediately behind abutments.

Friction Slabs (refer 75.1)

Friction slabs could be used to provide both longitudinal superstructure resistance and lateral restraint for superstructure diaphragm action.

However, many of the interaction uncertainties as mentioned in the preceding section on "Propped Superstructures" will also apply to friction slabs.

If the force levels at which friction slabs commenced sliding, could be confidently predicted, then significant energy dissipation could be allowed for in design.

Because of uncertainties in this regard, and to help allow for the attendant risk to linkages and other connections, design should be based on the assumption that friction slabs will generate large forces in the superstructure. Hence a "rigid structure" response and safety factor of 1.5 on assessed strength has also been allocated to this mode of resistance.

For similar reasons as apply to propped superstructures and friction slabs, tie back systems at bridge ends such as "dead man" or soil anchors should also be designed to "rigid structure" principles; i.e. $T = 0$.

C7.7 OTHER CONSIDERATIONS:

Integrity of Span to Pier Connections (refer 7.7.2)

It has been shown that a significant number of overseas bridge failures have resulted from inadequate connections and inadequate pier top seating. Ground deformations can combine with inertia effects in producing forces tending to pull spans from piers. On bridges with stiff substructures span to pier connections could have to absorb large inertia forces.

It is a requirement of capacity design to ensure that structural components have adequate shear strength in order to develop plastic hinges. A simple extension of this principle would likewise require that span to pier connections had a similar shear capacity.

C7.8 CULVERTS AND VERY SMALL SINGLE SPAN BRIDGES:

Culverts -

Damage to culverts due to lack of structural integrity occurred in the Inangahua earthquake^{7.6} and it is considered that the worst consequences of culvert failure or the failure of culvert components could be serious.

Inadequately designed head walls or wing walls with poor connections to the main barrel could allow part of the embankment to collapse into and obstruct the waterway. Stability of side slopes on embankments in the vicinity of culverts needs consideration. A flexible corrugated metal culvert if subjected to extreme soil deformation or loss of soil support could collapse with a similar result. Corrugated metal culverts may fail in a "snap through" buckling fashion when cross sectional warping reaches 20% of their diameter.^{7.4}

C7.9 REFERENCES:

- 7.1 Priestley, M.J.N., Evison, R.J., Carr, A.J., "Seismic Response of Structures Free to Rock on their Foundations"; Bull. N.Z. National Soc. Earthquake Engineering, Vol. 11, No. 3 September, 1978.
- 7.2 Taylor, P.W., Williams, R.L., "Foundations for Capacity Designed Structures", Bull. N.Z. National Society for Earthquake Engineering, Vol. 12, No. 2 June, 1979.
- 7.3 McCulloch & Bonilla, "Effects of the Earthquake of March 27, 1964 on The Alaska Railroad," Geological Survey Professional Paper 545-D.
- 7.4 Gray, P., Schofield, A.N., Shann, C.D., "Design and Construction of Buried Thin Wall Pipes", C.I.R.A. Report 1978.
- 7.5 Standards Association (N.Z.) "Code of Practice for Concrete Design, DZ 3101".

7.6 Duckworth, W.J.H., "Inangahua Earthquake Damage on Railways," Bull. National Soc. Earthquake Engineering, Vol. 1, No. 2 Dec. 1968.

Refer 7.5.1
7.5.2

Note: μ = Structure ductility factor.

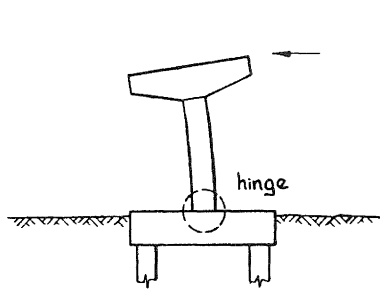

$\mu=6$

Hinge zone accessible.

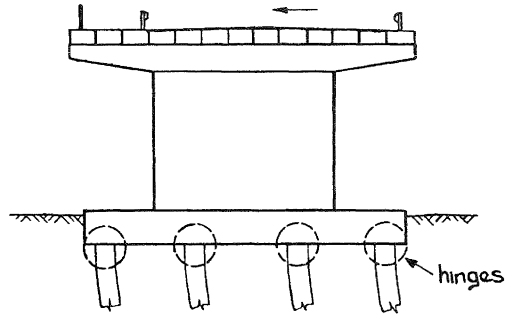

$\mu=4$

Where hinge zone is reasonably accessible in piles

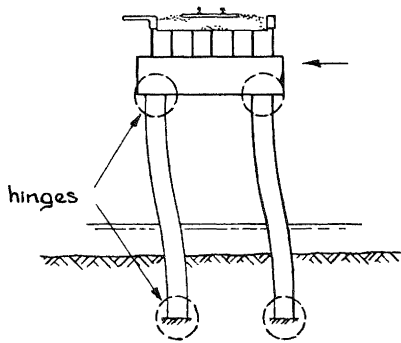

$\mu=3$

Where hinge zone is inaccessible below water or at considerable depth below ground.

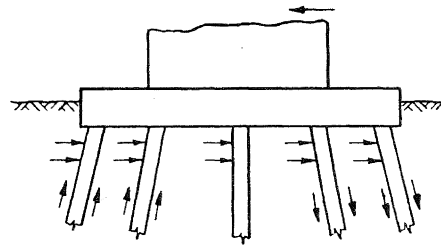

$\mu=2$

Raked pile interaction with soil.

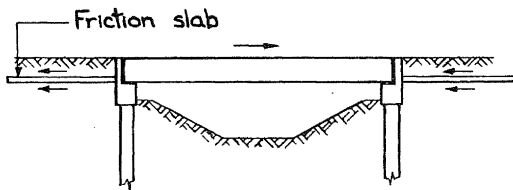

$C_H \mu (T=0)$
(assumed rigid restraint.)

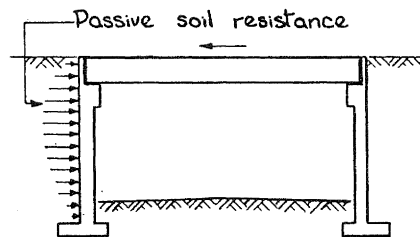

$C_H \mu (T=0)$
(assumed rigid restraint.)

FIG. 7.1 ASSUMED DUCTILITY & STRUCTURE RESPONSE FOR SMALL BRIDGES