

INNOVATIVE CONNECTIONS FOR PRECAST CONCRETE MOMENT RESISTING FRAMES

Farhad Behnamfar¹, Hadi Rafizadeh², and Mortza Omid²

(Submitted October 2014; Reviewed February 2015; Accepted July 2015)

ABSTRACT

This research work presents new details for moment connections in precast concrete structures satisfying both design and practice criteria. In this paper the results of the numerical study on the connections are presented. For the analysis, the ANSYS software is selected because of its diversity in nonlinear analysis. By calculating the monotonic load-displacement curve of each connection, the connections are evaluated for their stiffness, strength, and ductility.

The compressive strength of the connection concrete is taken to be 30, 35 and 40 MPa, for each round of analysis. The results of the analysis show that the proposed connections are stiff enough to be moment resisting and to be emulating an equivalent monolithic, or basic connection. It is illustrated that the connections are stronger but somewhat less ductile than the basic connection regardless of the concrete strengths examined. Moreover, it is shown that in each precast connection while increasing the compressive strength of concrete does not affect the connection stiffness considerably, it increases the ultimate load and ductility of the connection. As a main result of this study, the suggested connection details are categorized based on their stiffness, strength, and ductility. The suggested connections can be used in moment resisting precast concrete buildings based on the desired strength and ductility.

Keywords: Precast concrete, beam to column connection, nonlinear static analysis, stiffness, capacity, ductility.

INTRODUCTION

A brief look at the damage sustained in past earthquakes shows that failure in precast concrete buildings has been basically due to their inadequate connections while the precast members themselves have suffered minor damage or have not been damaged altogether. This observation leads to the reality that design and construction of joints in precast buildings possess a supreme importance and must be considered more closely.

Research on precast beam-column connections has been extensive and wide. Among experimental works, the NIST project [1-4] is a benchmark. In that project, 18 precast and 4 monolithic specimens were tested in total. In the precast connections tested, a combination of mild and high strength reinforcements was used. The research recommended that the flexural bars be located at top and bottom of the section due to their good nonlinear deformation capacity, and the prestressed strands be placed in the middle at the neutral axis. Also, a "bare" end was recommended for the mild steel so that inelastic action can be distributed over a sufficient length to prevent brittle failure (Fig. 1).

Another extensive research effort along the same lines was the PRESS project [5-7]. The PRESS project included three phases. In phase one, the geometries of some new precast connections were determined and presented. Phase two consisted of analysis and testing of selected new details. Specifically, four types of connections were tested, namely, the prestressed connections, yielding connections in tension and compression, hybrid connections, and gap connections with tension-compression yielding components (Fig. 2).

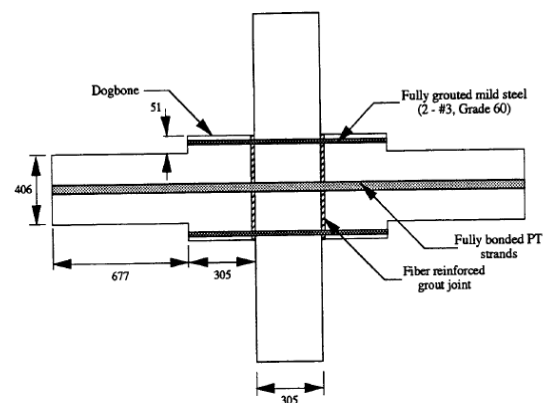

Fig. 1: Schematic of the precast connection recommended by the NIST project [1-4].

In phase three, a 60% scaled 5-story building was constructed and tested. To resist the earthquake, two moment frames were used in one direction and two precast walls perpendicular to it. In one of the moment frames, the hybrid connection was used in the first three stories with the prestressed connection in the remaining two upper stories. In the other frame, the gap and yielding connections were utilized in the lower three and the upper two stories, respectively.

¹ Associate Professor, Dept. of Civil Engineering, Isfahan University of Technology, Isfahan 8415683111, Iran. E-mail: farhad@cc.iut.ac.ir

² Graduate Student, Dept. of Civil Engineering, Isfahan University of Technology, Isfahan 8415683111, Iran.

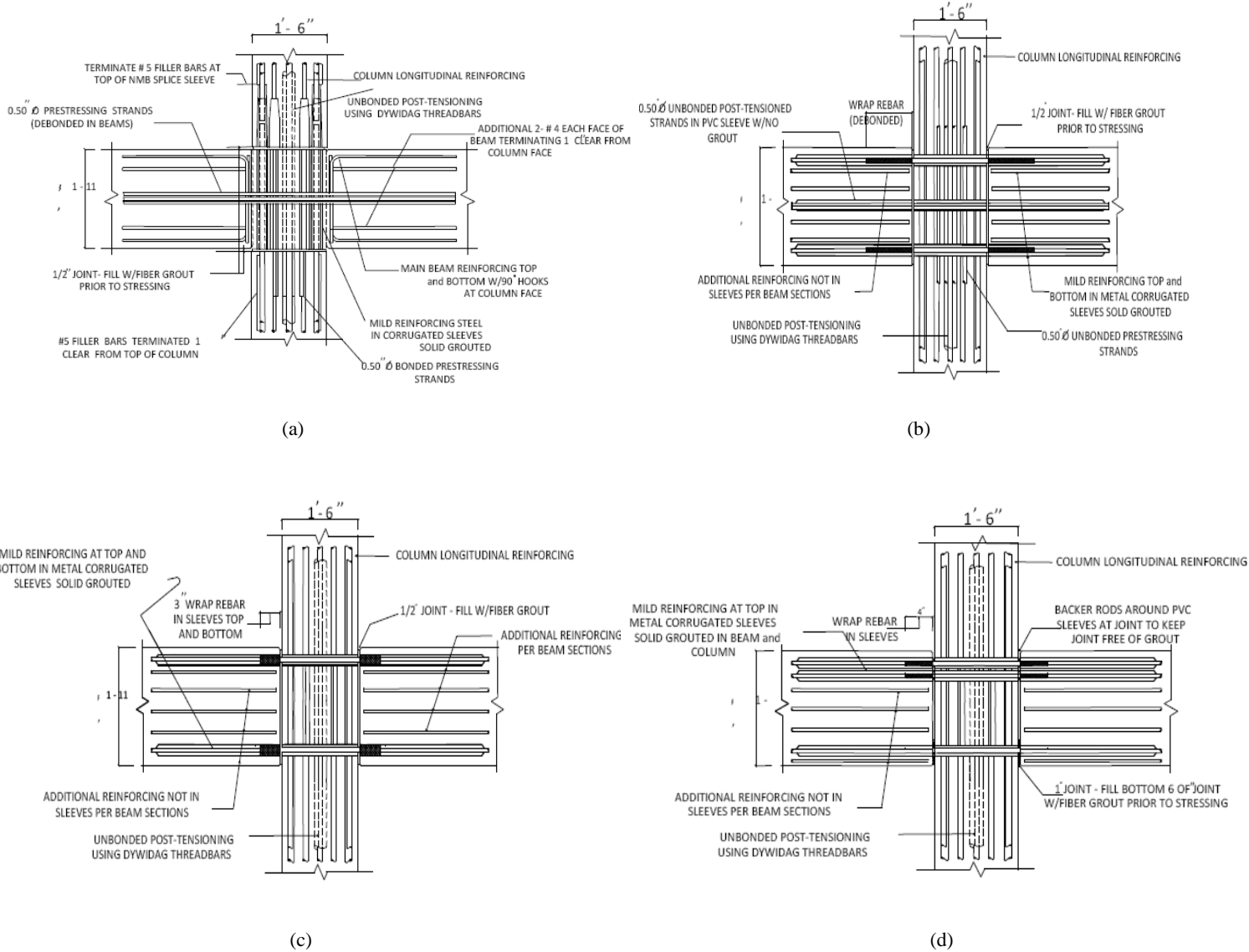

Fig. 2: The precast connections of the PRESSS project [5-7], including: (a) the prestressed, (b) the yielding, (c) the hybrid, and (d) the gap connection.

As a result of the experiment, the moment frame with hybrid and prestressed connections was reported to have a superior behaviour. The energy dissipation capacity of the frame with a yielding connection was observed to be more than that of the prestressed one.

In Bogazici and Kocaeli universities in Turkey, a research programme was accomplished in two phases on beam-column connections of precast buildings [8 & 9]. In the first phase, Ertas *et al.* designed and tested a monolithic and four samples of precast connections including in-situ concrete in the column zone, in-situ concrete in the beam zone, hybrid, and bolted connections. Regarding energy dissipation, the bolted connection behaved more adequately compared with other samples. In the second phase, four samples of the hybrid connection were tested at a 50% scale and it was concluded that increasing steel of the section results in a smaller reduction in connection stiffness and a larger energy dissipation tending to that of the monolithic sample (Fig. 3).

Khaloo & Parastesh tested a proposed beam-column connection in two phases [10]. The suggested detail consisted of a channel-shaped part of beam adjacent to column containing bars passing through holes in the column with the channel to be filled with fresh concrete later on. In the first phase of these experiments, the required length of the beam channel zone was determined. Results of the second phase

showed that reduction of column axial load increases ductility and strength of the connection and the samples built with fibre-infilled concrete had a better performance compared to other specimens. They reported that their precast connection was similar in strength and ductility to monolithic connections.

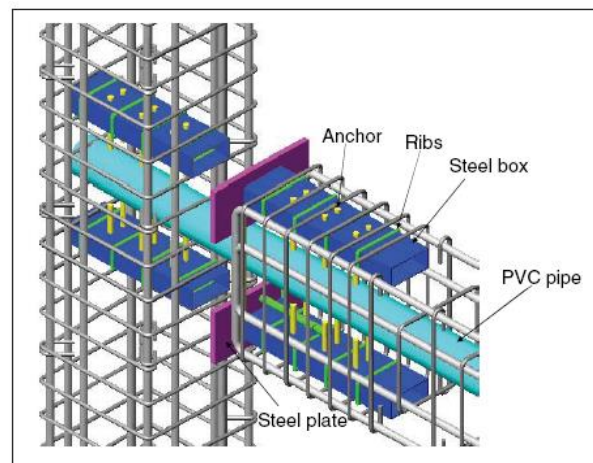

Fig. 3: The precast connections by Ertas *et al.* [8 & 9].

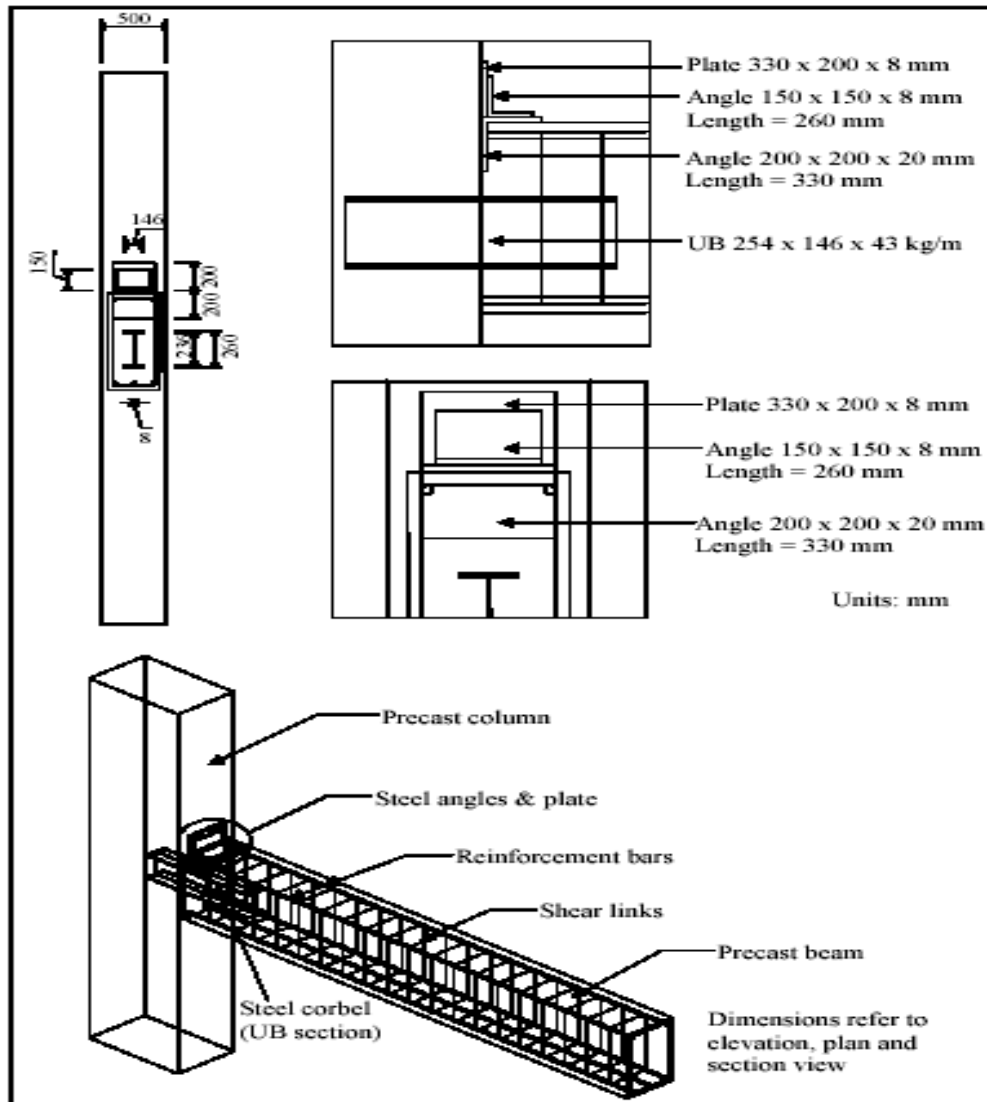

Fig. 4: The precast connection proposed by Lin [11].

Yeang Lin proposed six different details for precast beam-column connections and presented load-displacement, moment-curvature and deformation patterns of the connections [11]. In those connections, an I-profile was inserted in the column at the connection zone and a rectangular plate was welded to column reinforcements at the upper beam edge where an angle was installed in the beam. The angle and plate were welded together using an additional angle. Finally, it was concluded that utilizing angle and I-profiles in the connection resulted in a higher strength. On the other hand, increasing longitudinal and transverse reinforcement in the beam increased beam strength but barely changed the connection load capacity (Fig. 4).

Sudhakar & Bing Li studied four connection details including a monolithic and three precast connections. Their work showed that the axial load in a column did not affect the connection behaviour considerably. An increase in the thickness of the connection plate enhanced energy dissipation and load bearing capacity of the connection [12] (Fig. 5).

In this paper five new types of moment-resisting connections practically suitable for precast concrete frames are presented and their behaviour is evaluated under simultaneously applied vertical and lateral loads.

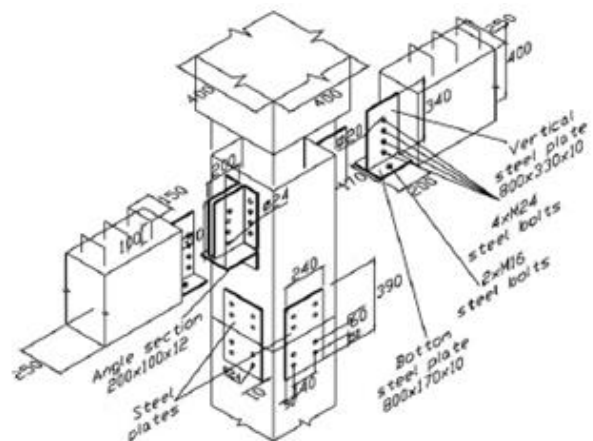

Fig. 5: The precast connections developed by Sudhakar & Bing Li [12].

BASIC DESIGN ASSUMPTIONS FOR THE PROPOSED CONNECTIONS

Considering the importance of connections in precast concrete structures, the purpose of this study is to present a

number of precast moment-resisting connections being suitable for rapid production and installation, as well as being safe enough under applied loads. In this research a total of six specimens, SP1 to SP6, were designed and tested. These included a monolithic one, as the basic connection, and five precast connections including four new details and a conventional one.

The basic assumptions for design of the connections are as follows:

1. All of the connections are interior joints with an ability of a four-way connection detail.
2. The systems under study are substructures consisting of beams and columns spanning half lengths from all four sides of the connection. The boundary conditions are a hinge support at the bottom end of the lower column and rollers at the three other boundaries. The section dimension of the beams and columns are identical at 300 by 300 mm.
3. As of loading, the vertical load is applied uniformly on the beam taking into account a dead load of 5 kN/m² and a 2 kN/m² of live load concurrently as common values and assuming a 3-m spacing between frames. Note that the section dimensions of the members have been taken such that the finite element model does not become too large. Also, the frame spacing (that is taken as about half of its usual value) has been selected consistent with the gravity loads and the selected section dimensions. The lateral load is applied one-way and increasingly at the top of the upper column. Therefore, an inelastic static analysis is to be performed on the connection.
4. For the connections steel plates, $f_y = 240$ MPa and $F_u = 400$ MPa, representative of mild steel, are used as yield and ultimate strengths, respectively.
5. The bolts are M5.6 with $f_y = 300$ MPa and $F_u = 500$ MPa.
6. Longitudinal and transverse reinforcement of the beams and columns in all specimens are the same as for the monolithic connection.
7. The connections are designed according to PCI 2004 [13].

THE CONNECTION DETAILS

Bolted - No Corbel Connection (SP1)

In this proposed connection, the beam is connected to the column through bolts and angles (Fig. 6).

First the lower angles of the beams are installed on the column using bolts, then the beams are placed on these angles and finally the upper angles are bolted to the assembly. After tightening the bolts, the remained spaces in bolt holes are filled with grout to provide adhesiveness between bolt and concrete and to prevent slip. Connections more or less similar to SP1 have also been proposed by other researchers [14-16].

No Corbel-Welded Connection (SP2)

As of Fig. 7, in SP2 steel plates are placed at the column sides using shear keys or shear tabs. In addition, there is an insert plate at the top and another one at the bottom of the

beam. They are embedded in the beam with the help of anchor bolts. The beam is connected to the column through these plates and seat and cover plates that are connected to the column. Use of the seat and cover plates makes the installation process easier with larger beam length tolerances as the need for a direct connection is eliminated.

To erect this connection, first the seat plate is groove welded to the column plate. Then the beam sits on this plate and the beam bottom plate is welded to the seat plate. Finally the top plate is placed at its location and welded to the beam and column plates, to complete the connection.

Corbel-Bolt Connection (SP3)

Despite their similarities, the difference between SP3 and SP1 connections is that at the bottom of the beam a corbel replaces the angle. In this connection, first the beams are placed on the corbels and then the top angles are installed using bolts passing through holes in the beam, column and corbel. Finally, similar to SP1, the bolt holes are filled with grout. Figure 8 illustrates the details of SP3.

Peripheral Box and Bolt Connection (SP4)

In this connection, the beam and column are connected using bolts. As of Fig. 9, at the top and bottom of this joint there are plates anchored to the interior of the beam. These horizontal plates are welded to vertical plates shown in section A-A in Fig. 9. They are wider than the beam and column and have holes at both ends for bolts to pass through.

The column dimensions along the beams have been made larger at the connection zone and two peripheral boxes are placed over and under this outcropping with bolt holes. The lower "belt" box is anchored to the column. The whole connection is erected using bolts as in Fig. 9. The main difference between SP4 and SP1 is that here the need for making holes through the beam and columns has been eliminated and the bolts surround these structural elements. Moreover, there is no need to use grouting for this connection.

Wet Connection with Corbel and Weld (SP5)

This is regarded as a conventional connection studied mainly here for comparison. Detail of SP5 is shown in Fig. 10. Part of this connection is precast and another part is constructed on site. To connect the beam to the column, moment resisting bars are used at the beam's top and the corbel and welding is utilized at the bottom. The bending longitudinal reinforcement passes through holes in the column section and continues for a distance along the beam. Also, the beam's bottom plate is welded to the corbel plate. Transverse reinforcement of the beam continues to the in-situ part to make the whole section work as a unit.

The Monolithic Connection (SP6)

This connection is a continuous part of the beam and column and results of its analysis are used as a reference for comparing the other connections. This connection has been designed according to ACI318-02. Detail of SP6 is shown in Fig. 11.

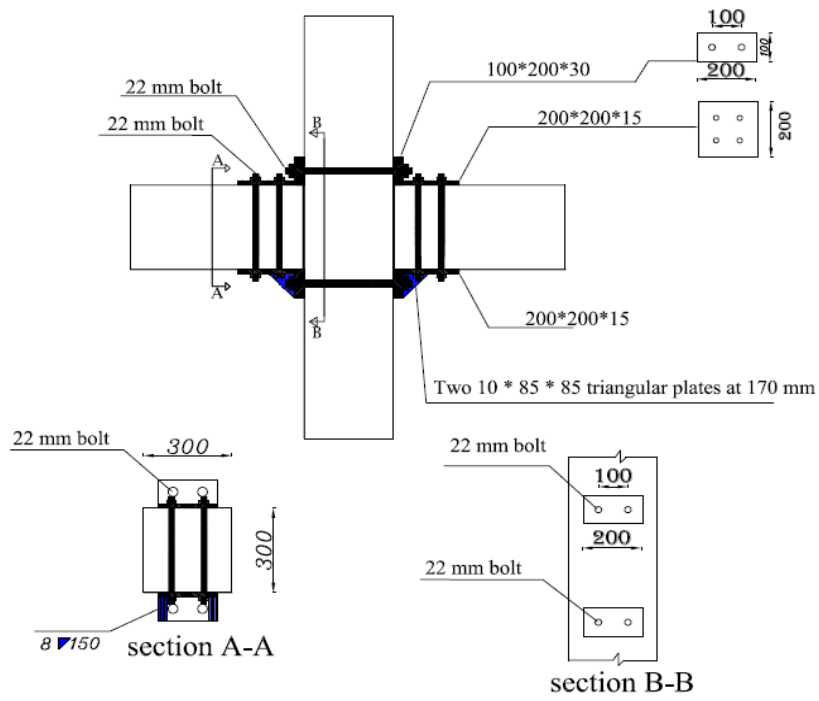

Fig. 6: The connection SP1, units in mm.

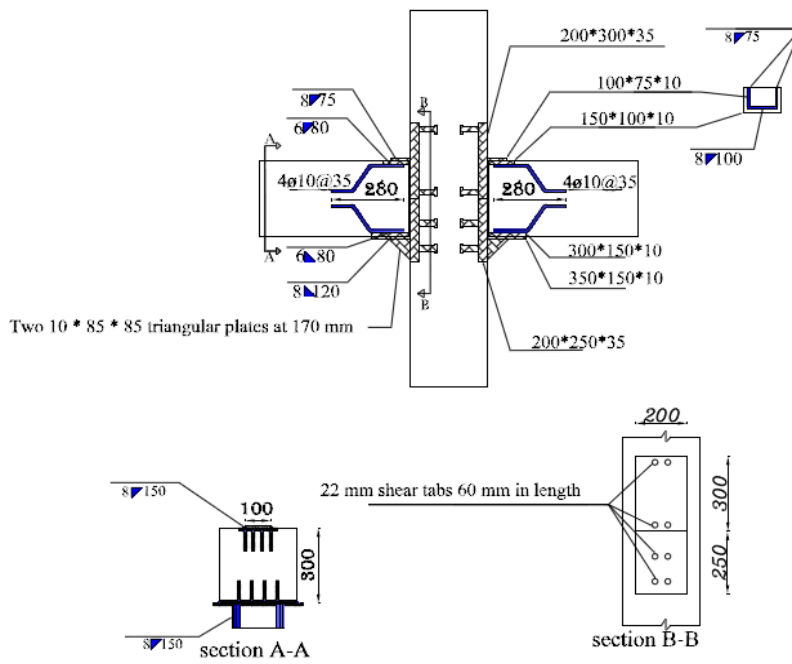

Fig. 7: The connection SP2, units in mm.

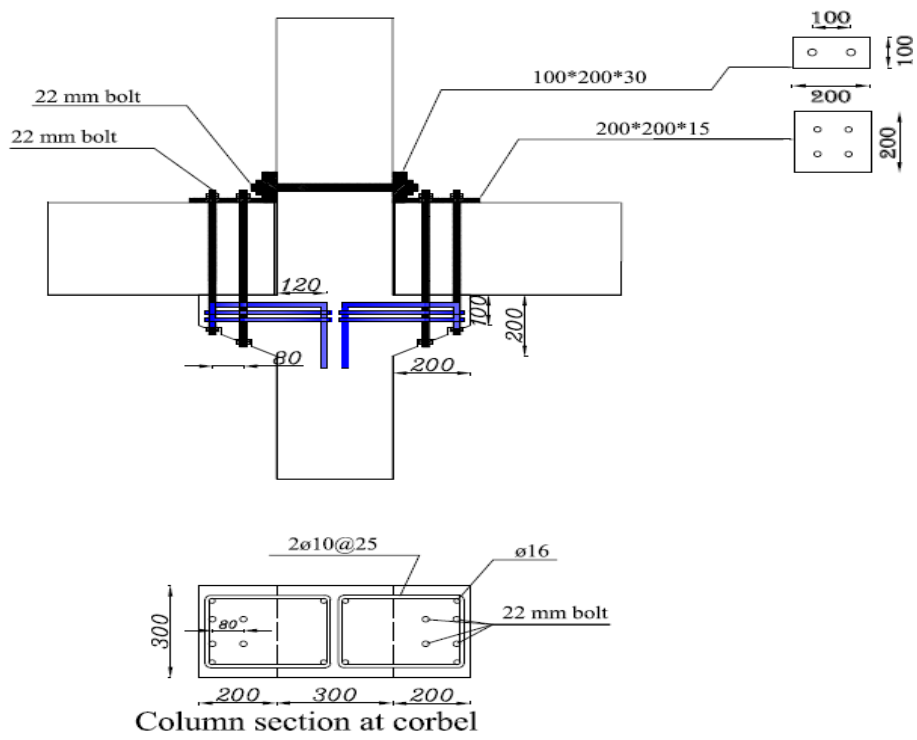

Fig. 8: The connection SP3, units in mm.

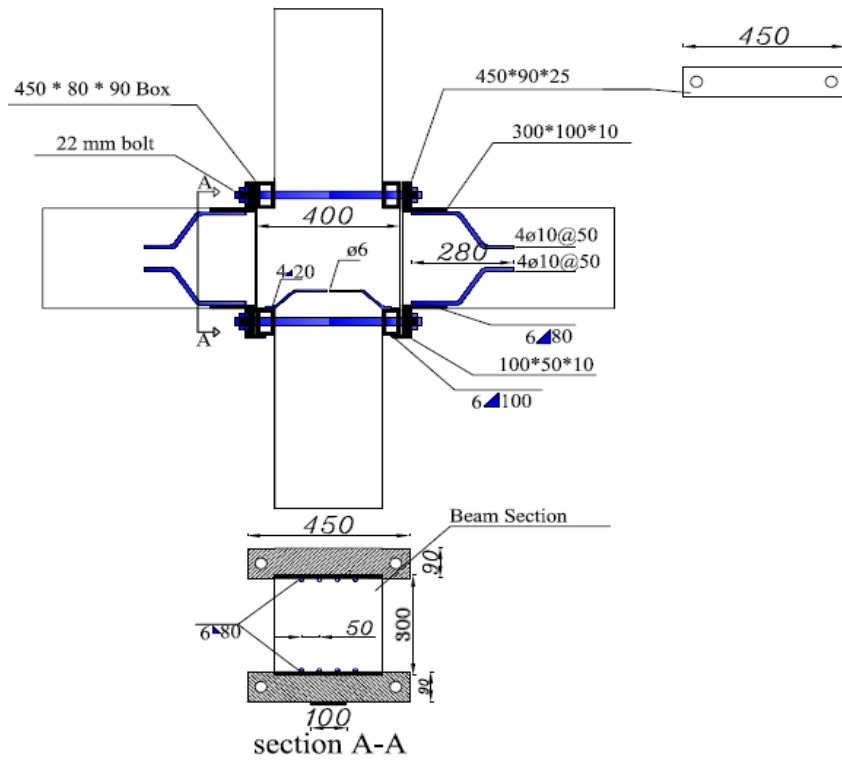

Fig. 9: The connection SP4, units in mm.

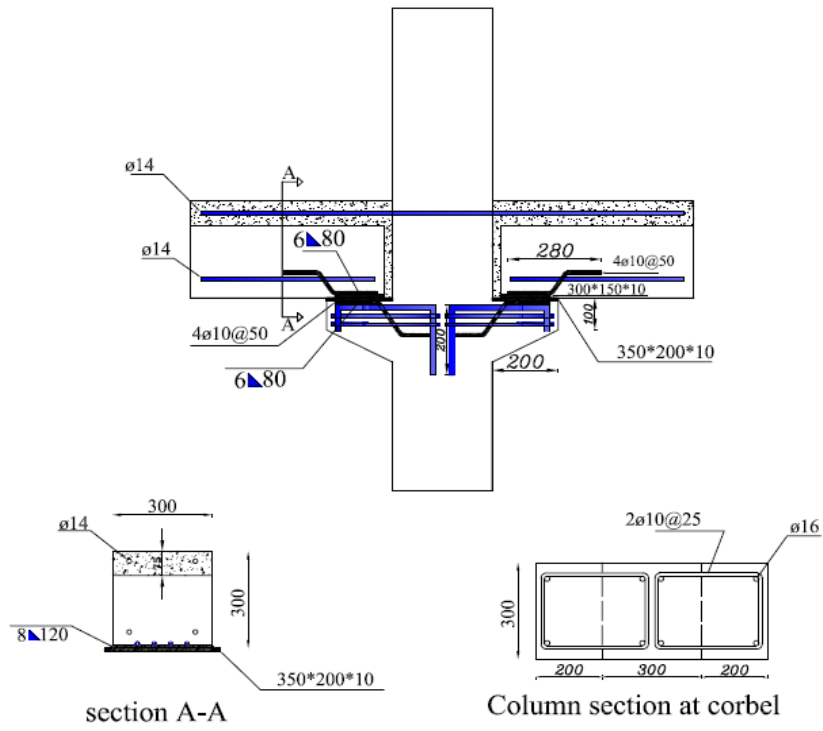

Fig. 10: The connection SP5, units in mm.

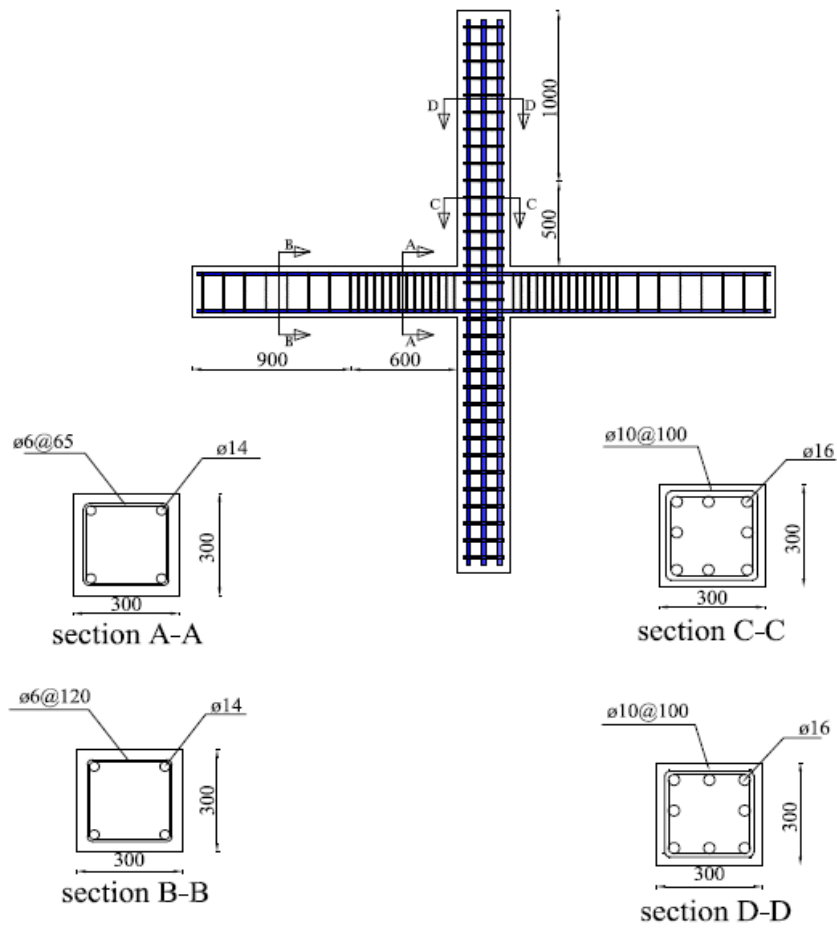

Fig. 11: The connection SP6, units in mm.

THE FINITE ELEMENT MODELLING

Modelling of the connections under study is accomplished nonlinearly using the Ansys software [17]. As observed in Figs. 6-11, models of SP1-SP6 consist of the following components:

1. Reinforced concrete: to model the RC medium, SOLID65 elements are used. This is the sole element in Ansys being able to model concrete segments with or without reinforcement. The considered volume may crack under tensile forces or crush under compressive loads. Additionally, reinforcement can be defined in three perpendicular directions in this element.

2. Steel plate and angle: For modelling of steel segments, the 8-node SOLID45 element able to include plastic and large deformations is utilized.

3. Shear tab: SOLID45 element is used to model the shear tabs too. The yield and ultimate stresses of shear tabs are 350 and 450 MPa, respectively, and the yield and ultimate strains are 1 and 4 percents, respectively, according to PCI2004 [13].

4. Bolt: Bolts are modelled with the SOLID45 element while pretensioning in bolts is modelled with pretension 179 elements.

5. Contact between surfaces: Appropriate simulation of contact between different surfaces is one of the most important tasks in modelling of a precast connection. When defining contact between adjacent surfaces, one surface is considered as the target and another as the contact surface. In modelling the target surface, use is made of the 4-node Target170 element. This element has three displacement degrees of freedom at each node in x, y and z directions. Also, the contact surface is modelled using the 8-node Conta174 element.

6. Reinforcement: The LINK8 element is used to model the longitudinal bars. This is a truss-type element where, similar to two-force members, bending is disregarded but creep, plasticity, and strain hardening are considered. In the connections under study, longitudinal and transverse bars are modelled using the discrete and merged methods, respectively. Since volume of the transverse reinforcement is not uniform along the members, the volumetric ratio of these bars have been computed in different parts as of Table 1 and were input to the software. In the discrete model use is made of link or beam elements attached to concrete nodes resulting in identical nodes for concrete and reinforcement meshing. In the merged method it is assumed that the bars are uniformly distributed in and merged to concrete elements in specified parts of the meshing. This method is usually used for large scale models in which it is perceived that exact details of reinforcement does not have an essential effect on the overall behaviour [18-20].

Table 1: Volumetric ratio of transverse reinforcement.

Assigned zone	Direction of trans. steel	Ratio of trans. steel
Beam, far from connection	z, y	0.00167
Beam, adjacent to connection	z, y	0.00408
Column, far from connection	z, x	0.005236
Column, adjacent to connection	z, x	0.0154
Connection zone	z, x	0.01026

7. Weld: In the connections studied, modelling of welds is disregarded owing to the fact that in appropriate connections the welds do not fail. To ensure this, the forces transferred through welds are computed and the adequacy of weld capacities are confirmed.

Stress-Strain Relations for Concrete and Steel

Stress-strain relation for reinforcement, steel plates and bolts are defined according to Fig. 12 as Eqs. (1-3):

$$f_s = E_s \varepsilon_s \quad \varepsilon_s \leq \varepsilon_y \quad (1)$$

$$f_s = f_y + (\varepsilon_s - \varepsilon_y) \left(\frac{f_{sh} - f_y}{\varepsilon_{sh} - \varepsilon_y} \right) \quad \varepsilon_y \leq \varepsilon_s \leq \varepsilon_{sh} \quad (2)$$

$$f_s = f_y + (f_u - f_y) \left[2 \left(\frac{\varepsilon_s - \varepsilon_{sh}}{\varepsilon_u - \varepsilon_{sh}} \right) - \left(\frac{\varepsilon_s - \varepsilon_{sh}}{\varepsilon_u - \varepsilon_{sh}} \right)^2 \right] \quad \varepsilon_s \geq \varepsilon_{sh} \quad (3)$$

In the above equations, f_s is stress, f_y is yield stress, f_{sh} is stress at the onset of strain hardening, f_u is ultimate stress, ε_s is strain, ε_y is yield strain, ε_{sh} is strain at the onset of strain hardening and ε_u is ultimate strain, all for steel. The Poisson's ratio of steel is taken to be 0.3. Also, for the reinforcement, values of the modulus of elasticity, the yield stress and the ultimate stress are assumed to be 200,000, 400 and 600 MPa, respectively. For the steel plates, S37 steel is used with yield and ultimate stresses being equal to 240 and 360 MPa, respectively.

Stress

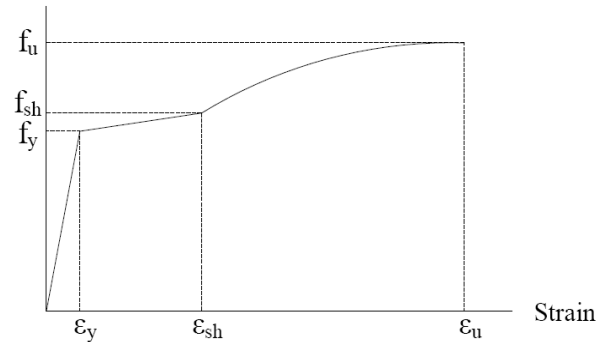

Fig. 12: The stress-strain curve for steel.

In the precast connections, the modulus of elasticity, yield strain and ultimate strain for the steel segments and bolts are 200,000 MPa, 1% and 4%, respectively, and for the longitudinal reinforcement they are 200,000 MPa, 1% and 14%, respectively.

For the stress-strain relation of plain concrete, the Hognestaad formula is used as Fig. 13 and Eq. (4):

$$f_c = f_c'' \left[\frac{2\varepsilon_c}{\varepsilon_0} - \left(\frac{\varepsilon_c}{\varepsilon_0} \right)^2 \right] \quad (4)$$

In Eq. (4), f_c'' and f_c' are the ultimate compressive stress and the 28-day compressive strength of concrete, respectively. f_c'' is calculated from the following equation:

$$f_c'' = k_s f_c' \quad (5)$$

The coefficient k_s for concrete having compressive strengths of 15, 20, 25, 30, and equal to or larger than 35 MPa is 1, 0.97, 0.95, 0.93 and 0.92, respectively.

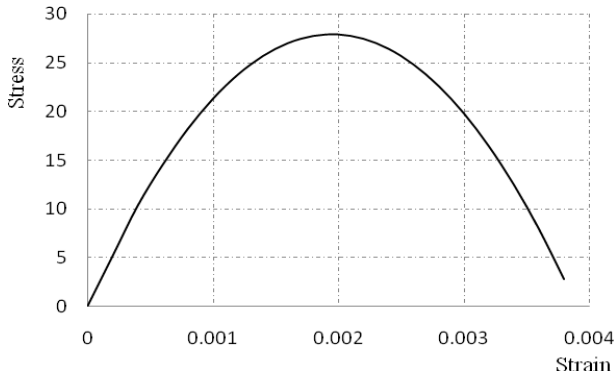

Fig. 13: The stress-strain curve for concrete.

Closely spaced transverse reinforcement is provided for confinement and this in turn increases the ultimate strain of concrete considerably. This has been accounted for in this study by using Mander's confined concrete model in the ANSYS analysis. Note that most nonlinear finite element analysis software cannot model the material failure. Therefore, they assume that after passing the peak stress in the stress-strain curve, the material keeps a constant residual stress. This unrealistic assumption is essential for the finite element codes in order to be able to converge and continue the numerical calculations. Of course this is not realistic, but fortunately it occurs at large displacements where the structure has already attained its ultimate capacity.

Modelling Assumptions

The following assumptions are made for modelling of different segments in SP1 to SP6 connections:

1. Contact elements are defined at the beam's end cross section and column face, between steel plates, and between steel plates and beam and column faces. It is to be noted that generally use of no-tension contact surfaces adds substantially to the computational time and leads to severe difficulties in converging the analysis. For this reason and since slip of bars is not normally a problem for wide-enough inner connections, no contact elements were defined at the exterior surfaces of bolts and shear tabs in contact with concrete, thus implicitly a perfect bond has been assumed at those locations. At bolted connections, activating the bolt in the model by applying the stiffening force of the bolts to the model is essential. Since the connections are of the bearing type, the value of the snug tight stress in a bolt is taken to be $0.1f_y$ and is applied along each bolt separately.

2. In SP4 connection, the plates above and below the beam are fully connected to the beam by four anchor bars. Therefore no contact element is defined for these plates by assuming a perfect contact, and a prestressing force is applied similarly.

3. Due to symmetry, at all connections only half of the assembly, when halved by a vertical plane, is modelled and appropriate boundary conditions are applied.

4. The basic connection (SP6) is analyzed assuming a fixed compressive strength of 30 MPa for concrete, but the same quantity for the precast connections varies as 30, 35 and 40 MPa.

5. Elements are sized such that the longitudinal bars pass through element nodes making it possible to locate these bars precisely. To have an adequate control on geometry definition, pyramid elements are used for steel segments. The number of elements used in SP1 to SP6 connections is as in Table 2. For instance, geometry of mesh and contact elements used in SP1 connection are shown in Fig. 14.

Table 2: Number of elements used for the connections.

connection	Solid65	Solid45	Link8	Conta174	Targe170	Prets179
SP1	7470	10303	453	574	1296	36
SP2	19177	3357	447	828	786	-
SP3	12979	4910	441	772	700	80
SP4	6620	5794	440	500	934	32
SP5	6960	170	539	140	150	-
SP6	6800	100	362	-	-	-

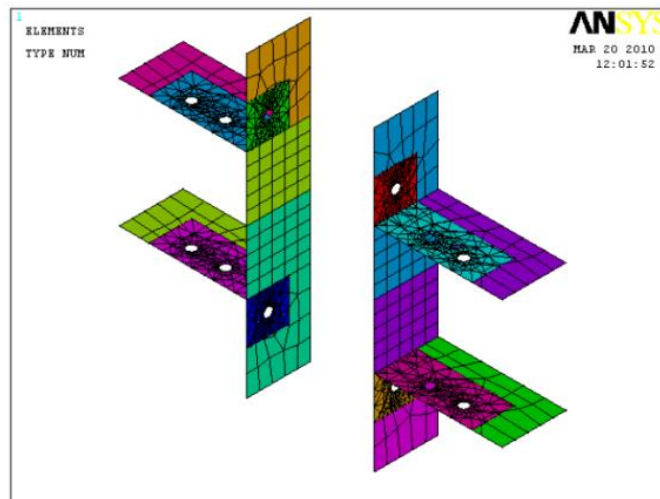
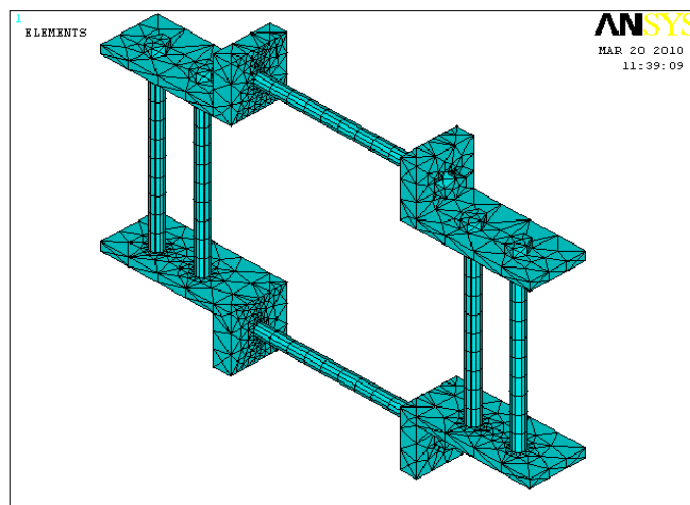
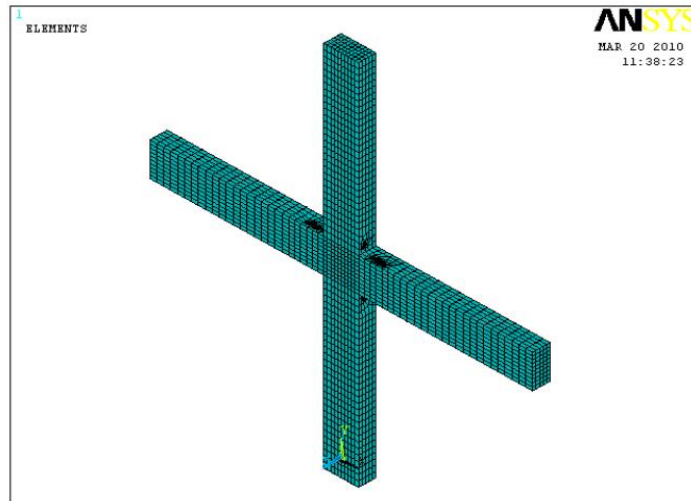

Fig. 14: Details of modelling of SP1; (a) concrete elements, (b) steel elements, (c) contact elements.

Verification Analysis

Before performing the main analysis of this research, it is necessary to verify the modelling procedure to be used. For this purpose, the results of an experiment by Cheok and Lew [1] on the A-M-Z4 connection of the first phase of the NIST project are assessed for comparison.

The setup and details of the above test are shown in Fig. 15. As shown, the specimen is a monolithic RC beam-column assembly under a constant vertical load equal to 9% of the compressive strength of the column and a varying lateral load. The boundary conditions are the same as were described in Sec. 2. The analytical model is developed using the assumptions of Sections 4-6.

The results of the pushover test and analysis are shown in Fig. 16. A satisfactory accuracy is observed in this figure. This prepares grounds for the main analysis of this research.

As observed in Fig. 16, the yield force is overestimated in the analysis at about 18% and the ultimate load is estimated at 12% to be smaller than the experimental value. Other than effects of mesh size and element type assumptions, the main reason for the above phenomenon seems to be the yield stress of the steel reinforcement, what was presumed for the stress-strain behaviour of the longitudinal reinforcement, and the ultimate compressive strength of concrete. The mentioned values control the yield point, the post-yield stiffness, and the ultimate strength of the component, respectively. Any difference between the values assumed for these quantities and the real characteristics of the material in the experiment, contribute to observing different paths in analysis and test.

On the other hand, since only the comparative behaviour of different specimens is meant, the above small discrepancies in the finite element analysis results should not distort the general findings of this study in the next sections. This is made clearer when one considers the fact that in calculating the response characteristics, a substitute bilinear path will be used instead of the curved path of the behaviour in this study. This technique results in less dependency on the point-by-point path of behaviour and in more refined results.

NONLINEAR STATIC ANALYSIS OF THE CONNECTIONS

An analytical model similar to Fig. 15 is used for determining the monotonic load-displacement behaviour of the connections. The details of the models are developed using the procedure of sections 4-6. The connections were analyzed for three different concrete strengths of 30, 35 and 40 MPa. The analysis of each connection was implemented to determine the lateral capacity of the system as the peak of the curve the tangent is horizontal. Although, it was not computationally possible to reach a zero stiffness in all cases where the calculations stopped at a very small lateral stiffness. Yet, it was possible to attain lateral displacements large enough for the purposes of this study. The load-displacement curves of the connections are shown in Fig. 17.

A special concern with SP2, the only connection with shear studs, is the possibility for the brittle failure of shear studs. Normally this cannot be captured readily with normal finite element analysis. Instead of looking into the gradual propagation of failure stress within the connection around the shear studs, it was preferred to obtain the capacity of shear studs using the equations of PCI2004 [13]. This was assumed to be the lateral capacity of the connection too.

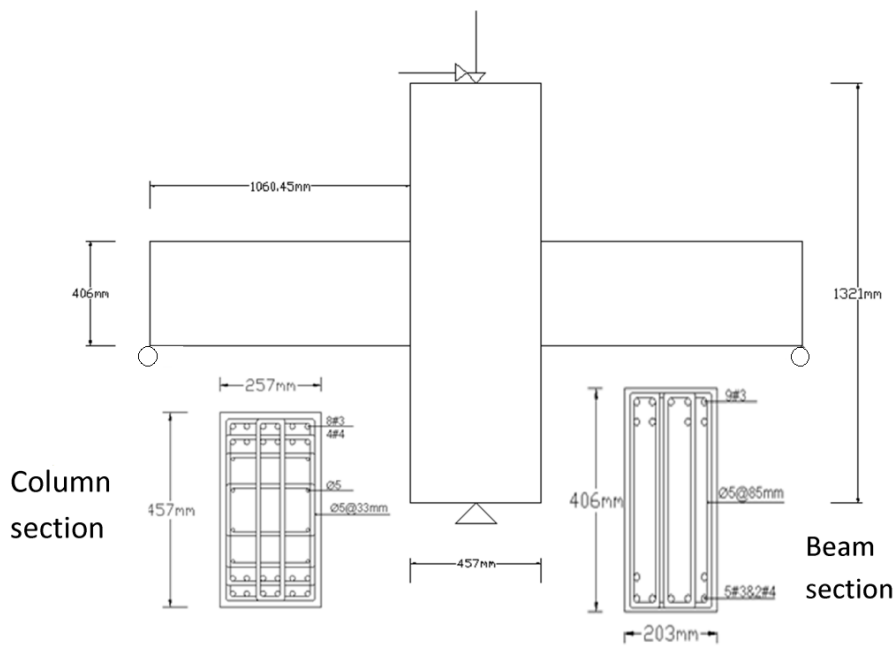

Fig. 15: The setup of the experiment used for verification analysis.

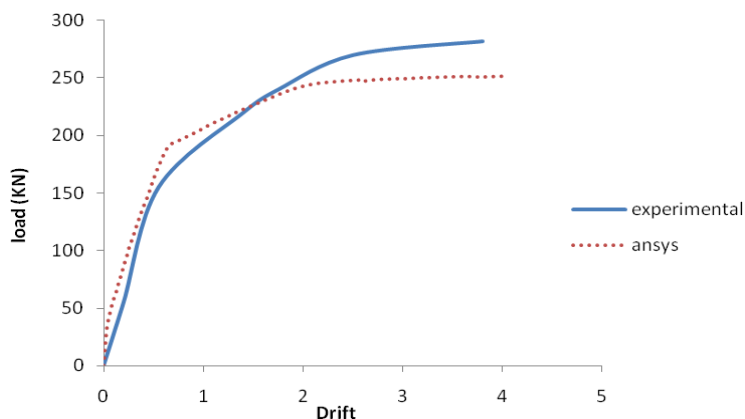
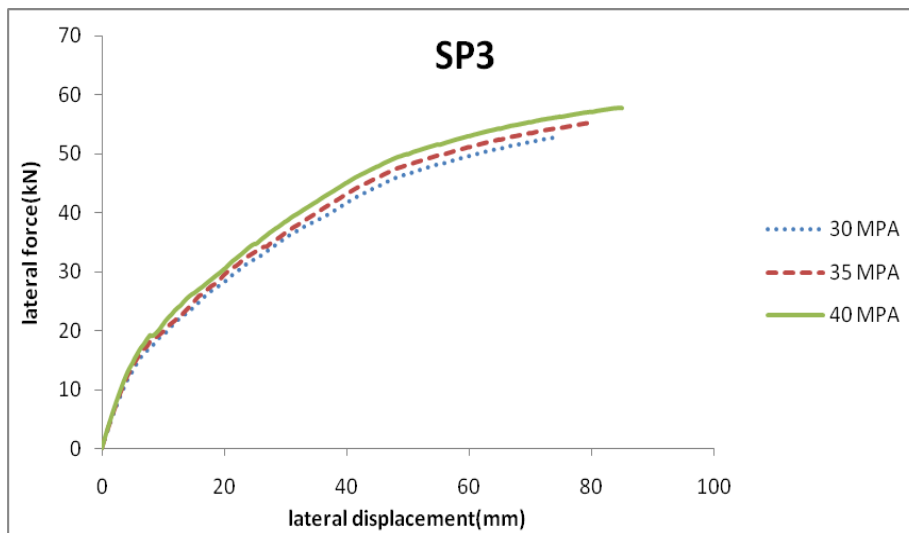
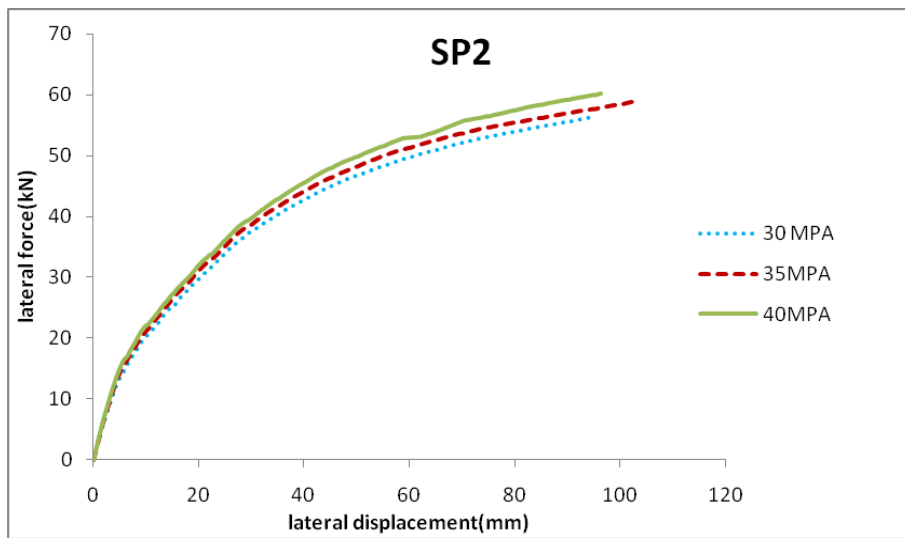
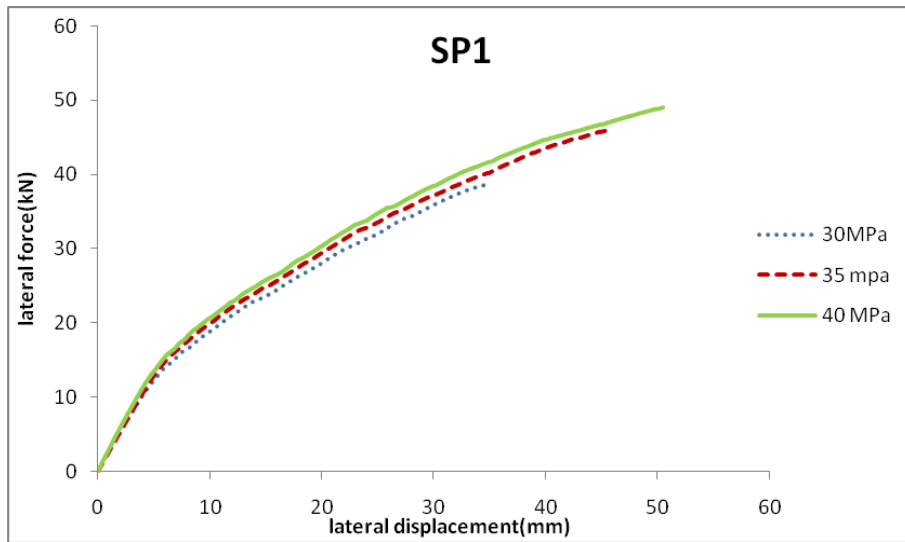

Fig. 16: Comparison of the behaviour of the verification assembly under lateral load due to test and analysis [1].



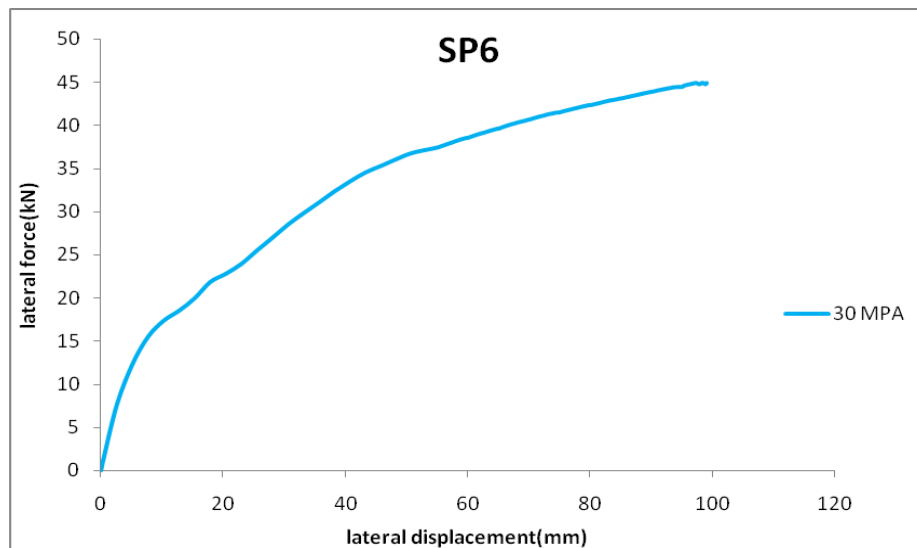
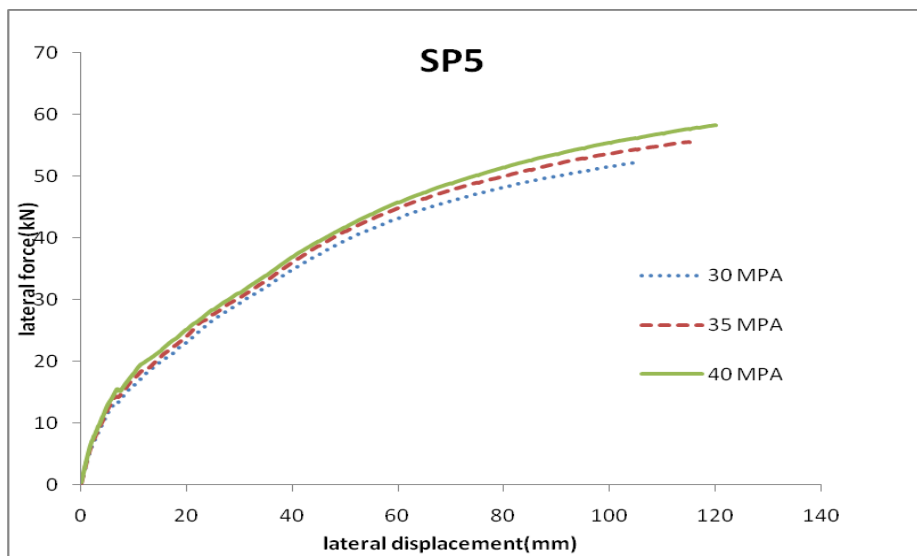
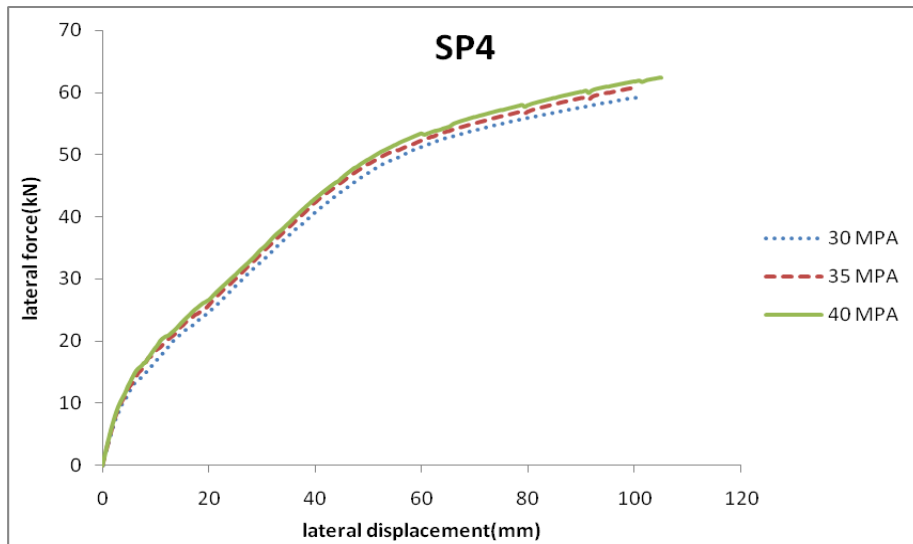

Fig. 17: Lateral behaviour of connections.

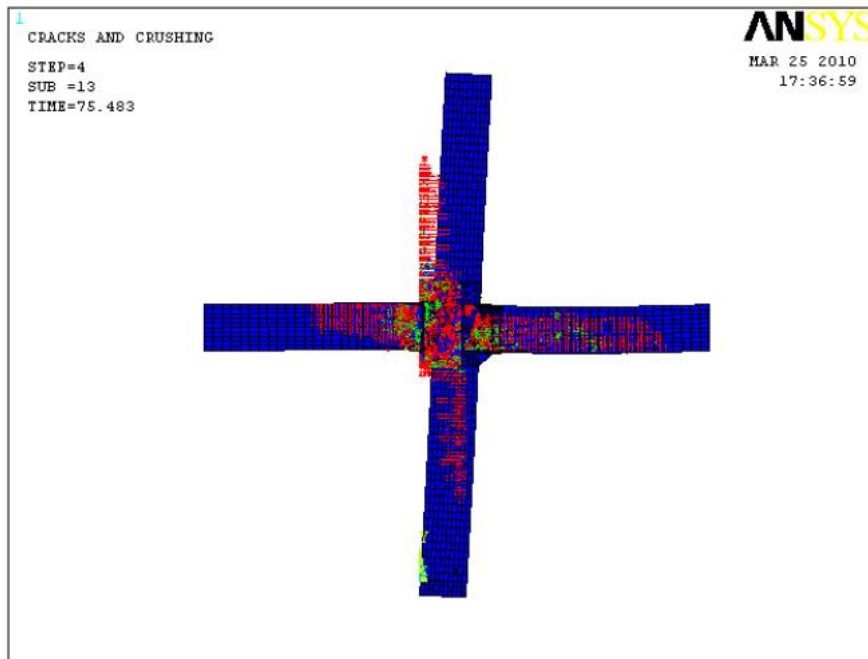

Fig. 18: Distribution of concrete cracks in SP2 at longitudinal bar yielding.

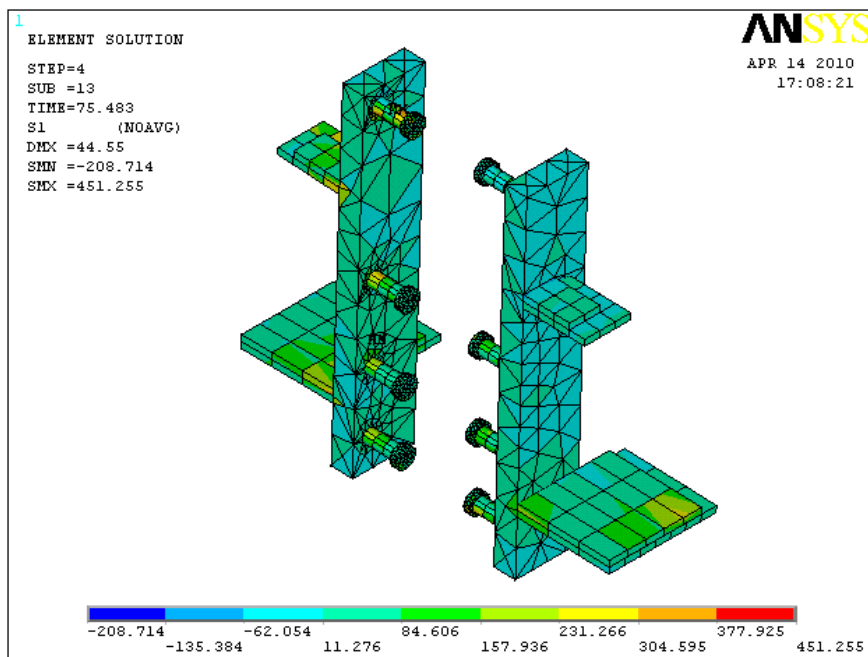

Fig. 19: Principal stresses in the steel segments of connection SP2 at failure.

As observed in Fig. 17, increase of concrete strength does not change the connection stiffness considerably but results in a relatively larger force capacity and ultimate displacement.

The maximum stress in the longitudinal reinforcement of the beam and column at each connection is shown in Table 3. Yielding of bars is observed for all concrete strengths in connections SP4 to SP6. For SP1 and SP2, the reinforcement yielded for concrete strengths of 35 and 40 MPa and in SP3 for 40 MPa. Therefore, it is anticipated that the connections SP4 to SP6 possess more ductility than the others. This will be shown in more detail in the next section.

Table 3: The maximum stress in the longitudinal bars at the connection zone (MPa).

Connection	Concrete strength (MPa)		
	30	35	40
SP1	304	400	401
SP2	294	400	400
SP3	182	314	400
SP4	404	412	422
SP5	410	435	464
SP6	400	-	-

Finally, comparing values presented in Table 4, the connections can be categorized from the viewpoint of stiffness, strength and ductility, as of Table 5. In this Table, the connection SP6 with a concrete strength of 30 MPa is taken as a connection with intermediate stiffness, strength, ductility and characteristics of other connections are compared with SP6.

On the other hand, as an established fact [21], ductility factors between 2 and 4 correspond to an intermediate level of ductility and values larger than 4 are representative of a high ductility level. Therefore, except of SP1 that turns out to be an intermediate connection, all other proposed connections are highly ductile components.

Table 5: Categorizing the connections with regard to their stiffness, strength and ductility. (L: low, M: medium, H: high; compared to SP6)

Concrete strength (Mpa)	Stiffness			Strength			Ductility		
	30	35	40	30	35	40	30	35	40
SP1	M	M	M	M	H	H	L	L	L
SP2	M	M	H	H	H	H	L	L	L
SP3	M	M	H	H	H	H	L	L	L
SP4	M	M	M	H	H	H	M	M	M
SP5	M	M	M	H	H	H	M	M	M
SP6		M			M			M	

DESIGN OF THE PROPOSED CONNECTIONS

This section outlines the design of each connection which can be used in engineering applications.

1. Connection SP1:
 - 1.1) Top and bottom cover plates on the beam: These plates are designed based on the tensile/compressive force produced by the moment acting on the connection.
 - 1.2) Bolts at the top and bottom cover plates: These components are designed as bearing bolts under a shear equivalent to the axial force of the cover plate.
 - 1.3) Top and bottom connection plates at the column: As the bolts at the same places act as bearing points for the plates, the column plates are designed under bending caused by tension of the beam plate. The bottom plate is taken to be same as the top plate although it resists a smaller tensile force because of presence of stiffener plates.
 - 1.4) Top bolts at the column: They are designed under the tensile force of the top cover plate.
 - 1.5) Bottom bolts at the column: These bolts are designed under the tensile force of the bottom plate and shear force of the beam at the connection.
 - 1.6) Bottom stiffener plates: The stiffener plates and their connection to the column plate are designed to transmit the beam shear at the connection with an eccentricity equal to half length of the stiffener plates.
2. Connection SP2:
 - 2.1) Inclined bars embedded in the beam: The size of the bars is determined based on the tensile force produced by the beam-to-column connection moment.
 - 2.2) Shear studs: The PCI handbook [13] is used for design of these components. Specifically, rupture and pull-out of the studs under combined action of tension and shear regarding their spacing, edge distance, and thickness of their bearing plate are considered.
 - 2.3) Other segments: Design of the cover plates and bottom stiffeners is similar to SP1.
3. Connection SP3:
 - 3.1) Upper plates and through bolts: These are designed similar to SP1.

- 3.2) Corbels: These segments are designed according to corbel design requirements of ref. [13], including design of the longitudinal and transverse reinforcements, and the seat plate.

4. Connection SP4:

- 4.1) Top and bottom cover plates are designed similar to SP1.
- 4.2) Column through bolts are designed for shear and for the tension produced by the beam's end moment.
- 4.3) The inclined bars are designed similar to SP2.
- 4.4) Column connection plates are designed for bending of the tensile force caused by the beam's end moment and for the beam shear using through bolts as bearing points.
- 4.5) The box sections are designed for the distributed bearing compression induced by the beam's end moment.

5. Connection SP5:

- 5.1) In this connection the longitudinal and transverse reinforcements are similar to the monolithic connection SP6. The corbel is designed similar to SP3. Thickness of the in-situ top concrete is 75 mm.

SUMMARY AND CONCLUSIONS

In this research five new moment resisting connections appropriate for practical precast concrete applications were introduced and their behaviour under concurrent vertical and lateral loads was compared to their equivalent monolithic connection. Nonlinear modelling and analysis of the monolithic connection were verified using an existing test result. The load-displacement behaviour of the assemblies were calculated through a nonlinear push-over analysis and were utilized for comparing the connection details from the viewpoints of stiffness, strength and ductility. Moreover, in each precast assembly, the compressive strength of the concrete was selected as a parameter accepting values of 30, 35 and 40 MPa in each analysis. The results of the study can be summarized as follows:

1. Considering the accomplished analysis, the suggested connection details possessed stiffness generally similar to a monolithic connection. For example, in SP4, the connection stiffness showed values just 19.6, 8.6 and 5.2 percent less than those of the monolithic connection for concrete strengths of 30, 35 and 40 MPa, respectively.

2. The stiffness of the studied connections was not sensitive to the compressive strength of concrete, but the ultimate load and the ductility increases with the concrete strength.

3. The lateral capacities of the proposed connections were uniformly larger than the monolithic connection. The difference was larger for the connections other than SP1. The strongest connection is SP4. In this connection angles and bolts have been used around the column. The second strongest was SP2, a connection with steel plates connected to the column with studs. The third ones were SP3 and SP5 with almost the same strength. In these connections the beam sat on a concrete corbel with/without steel plates. The connection SP1 that used steel plates and bolts in the beam and column had the lowest strength.

4. The most ductile connection among the assemblies studied was SP5. Regarding ductility, the other connections in descending order were SP4, SP2, SP3, and SP1. The connections SP4 and SP5 can be used in ductile frames in highly seismic areas.

REFERENCES

- Cheok G and Lew HS (1991). "Performance of 1/3 Scale Model Precast Concrete Beam-Column Connections Subjected to Cyclic Inelastic Loads". Report No. 2, NISTIR 4433, NIST, Gaithersburg, MD.
- Cheok G, Stone W and Lew HS (1992). "Partially Prestressed and Debonded Precast Concrete Beam-Column Joints". *Proceedings of Meeting of U.S.-Japan Joint Technology Coordinating Committee on Precast Seismic Structures System*, November 1992.
- Cheok G and Lew HS (1993). "Model Precast Concrete Beam to Column Connections Subject to Cyclic Loading". *PCI Journal*, **38**(4): 80-92.
- Cheok G, Stone W, and Lew HS (1993). "Performance of 1/3 Scale Model Precast Concrete Beam-Column Connections Subjected to Cyclic Inelastic Loads". Report No. 3, NISTIR 5246, NIST, Gaithersburg, MD.
- Ghosh SK and Hawkins NM (2003). "Codification of PRESSS Structural Systems". *PCI Journal*, **48**(4): 140-143.
- Nakaki SD, Stanton JF and Sritharan S (1999). "An Overview of the PRESSS Five Story Precast Test Building". *PCI Journal*, **44**(2): 26-39.
- Priestley MJN, Sritharan S, Pampanin S and Conley J (1999). "Preliminary Results and Conclusions from the PRESSS Five-Story Precast Concrete Test Building". *PCI Journal*, **44**(6): 42-67.
- Ertas O, Ozden S and Ozturan T (2006). "Ductile Connection in Precast Concrete Moment Resisting Frames". *PCI Journal*, **51**(3): 66-76.
- Ertas O and Ozden S (2006). "Behavior of Unbonded, Post-Tensioned Precast Concrete Connection with Different Percentages of Mild Steel Reinforcement". *PCI Journal*, **52**(2): 32-44.
- Khaloo AR and Parastesh H (2003). "Cyclic Loading Response of Simple Moment-Resisting Precast Concrete Beam-Column Connection". *ACI Structural Journal*, **100**: 440-445.
- Yeanglin N (2004). "Behaviour of Beam to Column Connection in Precast Concrete Structures". Civil Engineering, University Teknologi Malaysia.
- Sudhakar A, Kulkarni BL and Kwong YW (2006). "Finite Element Analysis of Precast Hybrid Steel-Concrete Connections under Cyclic Loading". *Journal of Constructional Steel Research*, **64**(2): 190-201.
- PCI Design Handbook (2004). "Precast and Prestressed Concrete". Prestressed Concrete Institute, Chicago.
- Mohamed SAM (1992). "Behaviour of Sleeved Bolt Connections in Precast Concrete Building Frames". PhD Thesis, University of Southampton.
- Aninthaneni PK and Dhakal RP (2014). "Conceptual Development: Low Loss Precast Concrete Frame Building System with Steel Connections". *NZSEE Annual Conference*, Auckland, Paper No. O44.
- Negro P, Toniolo G (2012). "Design Guidelines for Connections of Precast Structures under Seismic Actions". European Commission, Joint Research Centre, Institute for the Protection and Security of the Citizen, Ispra (VA), Italy, 84 pp
- ANSYS (2005). "Release 10.0 Manual Documentation for ANSYS Software". ANSYS Inc., Canonsburg, PA, USA.
- Anthony J (2004). "Flexural Behaviour of Reinforced and Prestressed Concrete Beams Using Finite Element". M.Sc. Thesis, Faculty of the Graduate School, Marquette University, Milwaukee, Wisconsin, USA.
- Camarena D (2006). "Finite Element Analysis of Precast Prestressed Beam-Column Concrete Connection in Seismic Construction". M.Sc. Thesis, Chalmers University of Technology, Göteborg, Sweden.
- Yalcin C and Saatcioglu M (2000). "Inelastic analysis of reinforced concrete columns". *Computers and Structures*, **77**(5): 539-555.
- ASCE (2014). "Seismic Evaluation and Retrofit of Existing Buildings". ASCE/SEI 41-13. doi: 10.1061/9780784412855.in