

Field experience section

## EARTHQUAKE RECORDING INSTRUMENT:

## THE TYPE M.O.2. STRONG MOTION ACCELEROGRAPH

G. K. Bunce\* \*

---

### 1. Introduction

Recognising that the only practical method for obtaining the primary data on earthquake resistance in large structures is to measure their behaviour during earthquakes, the Department of Scientific & Industrial Research realised there was a need both in New Zealand and overseas, for a low-cost, strong motion earthquake recording instrument suitable for use in multi-storey buildings and other important civil engineering structures.

Accordingly, Messrs Skinner and Duflou of the Physics & Engineering Laboratory, Department of Scientific & Industrial Research, embarked upon an intensive development programme resulting in the present design, which is known as the M.O.2 Accelerograph. M.O.2 indicates the instrument is functionally dependent upon mechanical and optical primary sensing elements and that this is the second design. The first design was not produced commercially.

In 1966, Messrs Victoria Engineering Limited of Lower Hutt were awarded the manufacturing rights and immediately began quantity production of the instruments.

Following introduction by the City of Los Angeles of a mandatory Building Code Ordinance, requiring three strong motion earthquake recording instruments to be installed in every building over six storeys in height with a floor area in excess of 60,000 sq.ft, or any building over 10 storeys, a substantial demand arose in that area.

Several M.O.2 Accelerographs were delivered to the U.S. Coast & Geodetic Survey, receiving that Authority's approval in 1967. Then followed approval by City of Los Angeles (Research Report No. 23362), and a U.S. distributor was appointed.

---

\* Director, Forgan Jones Ltd., Auckland.

To date some 150 instruments have been despatched to North America where they have proven to be highly satisfactory in service and most competitively priced. Other U.S. Municipal Authorities have now adopted similar ordinances to Los Angeles. Instruments are also located in New Guinea, South America, Rumania and Italy, this latter country having indicated interest in a further 100 units.

A 1969 Rothman's Design Award was granted to the instrument.

## **2. Description of Instrument**

The M.O.2 Strong Motion Accelerograph is a moderately priced instrument designed to measure earthquake generated accelerations on the ground and throughout major structures. For earthquake recording, it is automatically actuated by means of an electromagnetic trigger sensitive to vertical vibrations, and can also be actuated by means of external terminals.

It is designed to provide accurate and reliable acceleration data in three axes. Being portable, it can be operated either in the field or in permanent installations. When used for field work, the accelerometer block must be removed during transit unless the instrument can be kept within 5 degrees of horizontal. Since there is no current drain, except when operating, the batteries have an extended life in the standby condition, before requiring re-charging. Re-chargeable batteries are recommended for use with the M.O.2.

The optical recording system uses 24 feet of 35 mm photographic film which provides nine successive records of 47 second duration, or if requested six 70 second records, and is contained in a detachable film cassette. To change film, it is necessary to pre-load the cassette in a dark room; subsequent installation in the accelerograph, can be performed in daylight.

Three small accelerometers for recording mutually perpendicular accelerations, each carrying a spherical mirror which forms part of its mass, and each having a spherical seating to permit presetting, are housed in a single block, together with a fixed spherical mirror which provides a reference trace.

A light source consisting of a small 0.3 watt, 6 volt lamp mounted close to an 0.002 inch diameter pinhole, mounted in a housing with an adjustable spherical seating is used to direct the light beam emerging from the pinhole on to the four mirrors

in the accelerometer block. A counter, mounted under the cover, may be viewed at all times through an inspection window, indicating the number of recordings taken. This counter is easily re-set after each servicing simply by pressing the re-set button.

When used in a network, two or more M.O.2's can be interconnected to start simultaneously, giving common timing marks on all instruments, the marks being generated by a clock located in one (the master) instrument.

### 3. Operation

The layout of the Accelerograph components can be seen at Figs. 1(a) and 1(b), the basic components being mounted on the base and the auxiliary items mounted on the upper part.

The basic part of the instrument is the assembly of three small accelerometers, housed in a detachable block, their movements being recorded photographically by means of an optical lever. The spherical mirrors, mounted on the accelerometers, focus the three recording traces on to the surface of the recording film. The fourth spherical mirror, rigidly mounted, provides the reference trace. To provide a time base, the lamp current is interrupted to give 50 marks per second and 5 marks per second, control being achieved by a highly accurate (0.1 percent) tuning fork clock. Damping is set at approximately 60 percent of critical by immersion of the accelerometers in 10,000 cs silicone oil and can be adjusted by varying the oil viscosity. The primary elements are shown diagrammatically in Figs. 2(a), (b) and (c).

Automatic starting and stopping for successive earthquakes is controlled by auxiliary components, the actuator being an electromagnetic trigger sensitive to vertical vibrations. When excited, this trigger activates an electronic circuit which switches on the lamp and the film drive motor. The electronic circuit also provides speed control for the precision film drive motor. Two external 6 volt, lead dioxide, re-chargeable batteries in series supply the 2 watts required to operate the accelerograph.

The electromagnetic trigger, which is not sensitive to sag or slow tilt, contains no electric contacts and is not subject to changes in sensitivity.

#### 4. Specification

Recording Limits: 0.01g minimum to 1.0g maximum.

Accelerometers: Two horizontal and one vertical with a natural period of 0.03 second.

Recording Traces: Total of four traces; three acceleration traces, one fixed trace for reference. Trace Width - 0.003 inch (0.075 mm).

Accelerometer Sensitivity: Horizontal sensors - 1.5 cm/g, vertical sensor - 2.2 cm/g.

Timing: Trace interruption at 50 cps and 5 cps with 0.1 percent accuracy.

Starter: Vertical direction sensing trigger (moving coil type); adjustable sensitivity approximately 0.01g.

Recording Mechanism: A 6 volt, direct current precision motor drives the 3 inch film take-up spool through a gear box, the motor being controlled by an electronic circuit, in order to stabilize its speed. A friction clutch limits torque on the gear box in the event of film running out or when the film is rewound.

Dimensions & Weight: 17 $\frac{1}{4}$ " long, 7" wide and 7" high. Net weight 20 pounds. Gross Shipping Weight, 40 pounds. Volume 1.16 cubic feet (packed for shipment).

Operating Temperature Range: +35°F to 130°F.

Power: Two 6 volt, lead dioxide, re-chargeable batteries in series mounted externally, 2 watts required for recording. No power required during standby.

Alternative Power Supply: A 12 volt battery is satisfactory provided it can deliver 2 watts of power.

Miscellaneous: Provision is made for interconnection for multiple instrument starting and timing, external power supply and external voltage testing.

A built-in recording counter and re-set button is mounted in the top plate and is viewed through an inspection window - indicates number of accelerograph starts.

All instruments are tested and calibrated prior to despatch from the manufacturer (Figs. 3(a) and (b)). Individual serial numbers are allocated to each instrument, control circuit board and accelerometer block, calibration data on the accelerometer being marked on the data sheet included with the Installation and Operating Manual supplied with each instrument.

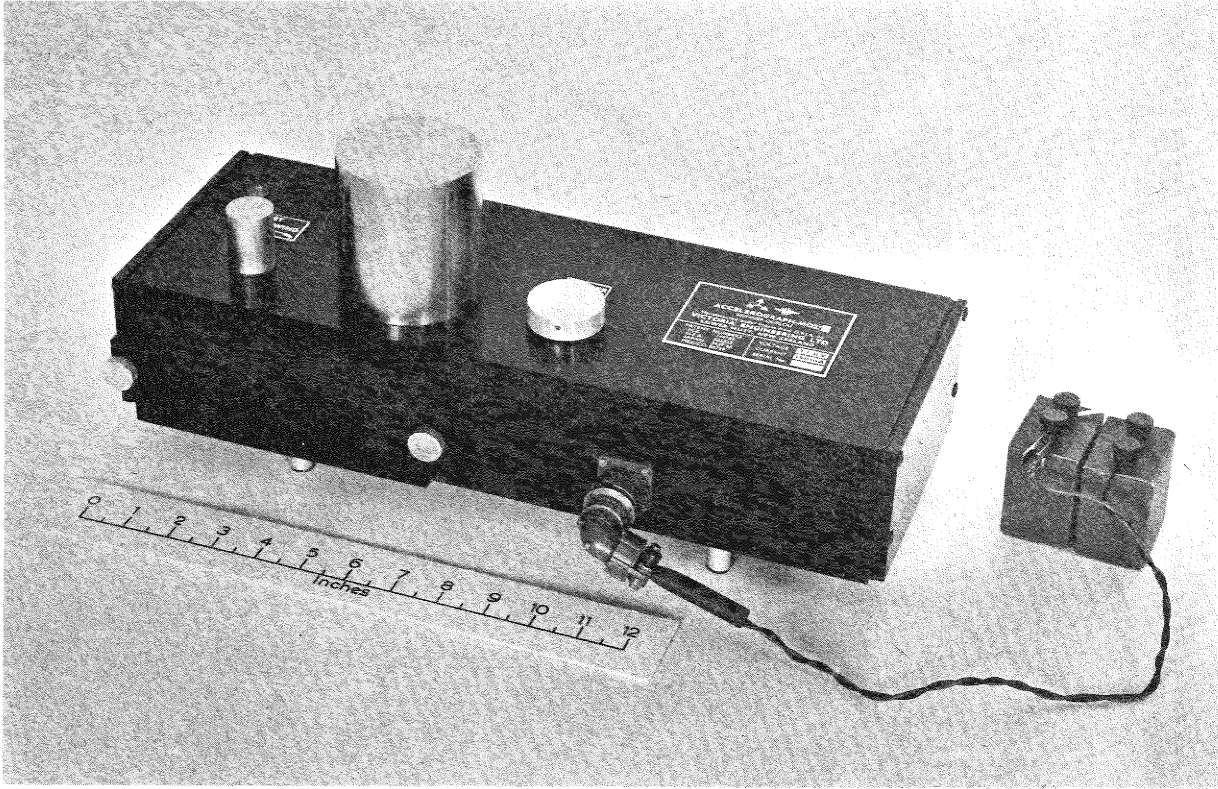

Fig.1(a): M.P.2 Strong Motion Accelerograph

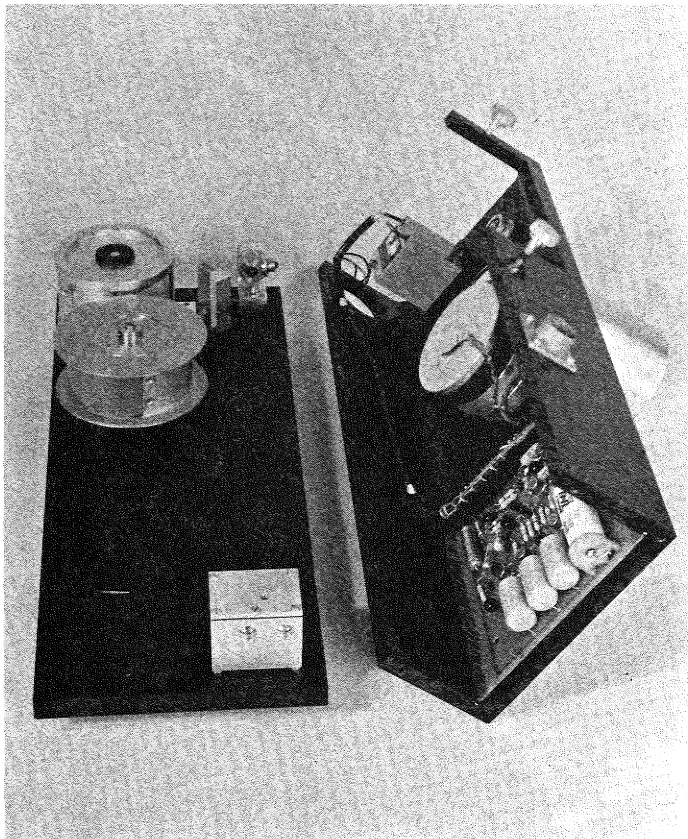

Fig. 1(b): The Accelerograph with upper part removed from the base

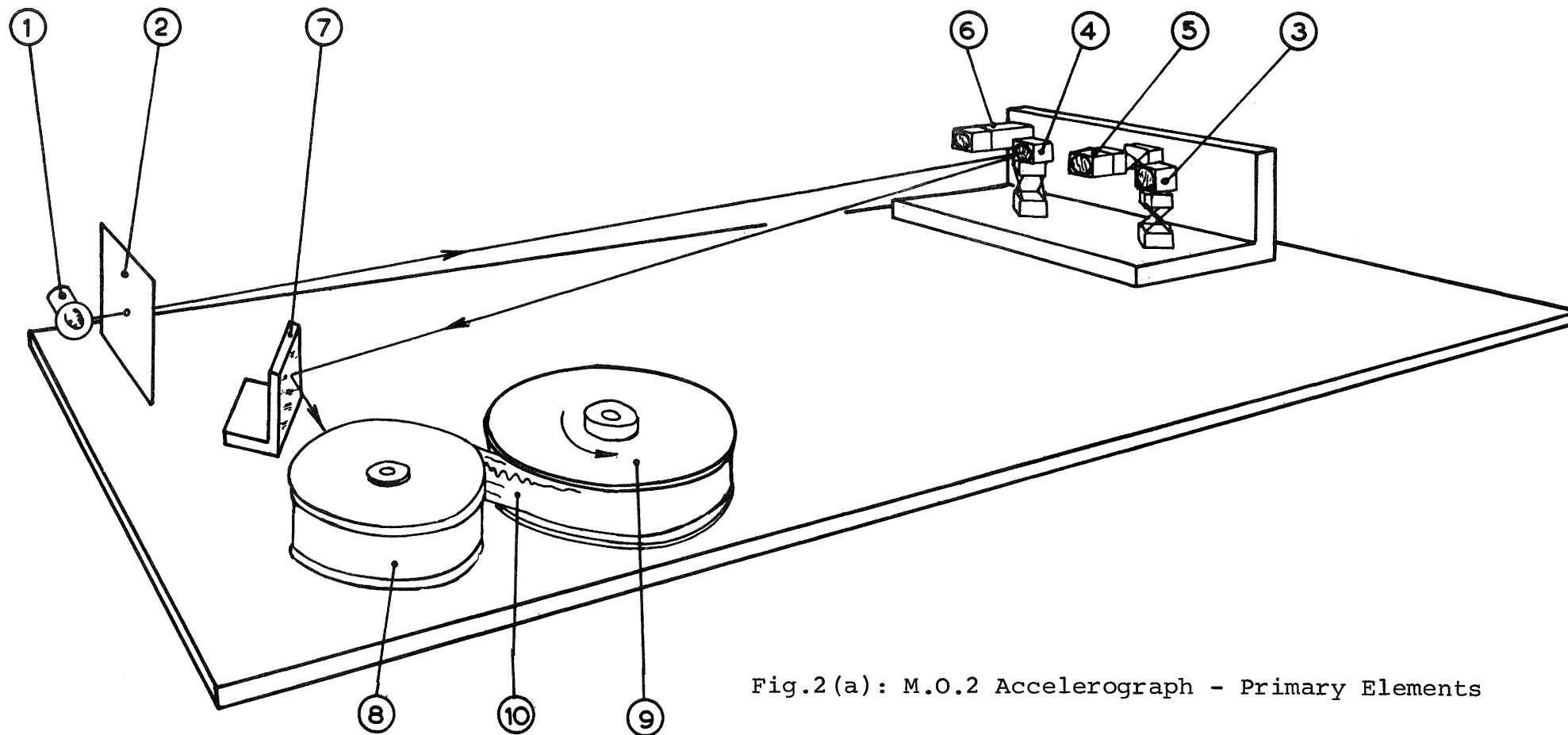

Fig.2(a): M.O.2 Accelerograph - Primary Elements

- |                           |   |   |
|---------------------------|---|---|
| 1. Lamps                  | 7. Fixed deflection mirror                | 13. Part of accelerometer mass  |
| 2. Pinhole                | 8. Film Cassette                          | 14. Spherical mirror which constitutes the remainder of accelerometer mass. |
| 3. E-W Accelerometer      | 9. Film Drive spool                       | 15. Accelerometer base  |
| 4. N-S Accelerometer      | 10. Recording photographic film           | 16. Damping paddle, attached to (13)  |
| 5. Vertical Accelerometer | 11. Outer parallel pair of crossed wires. | 17. Damping fluid.  |
| 6. Fixed reference mirror | 12. Inner parallel pair of crossed wires. |   |

Note: An auxiliary system is used to switch the accelerograph on for the duration of severe earthquakes in such a way that a number of successive earthquakes can be recorded automatically.

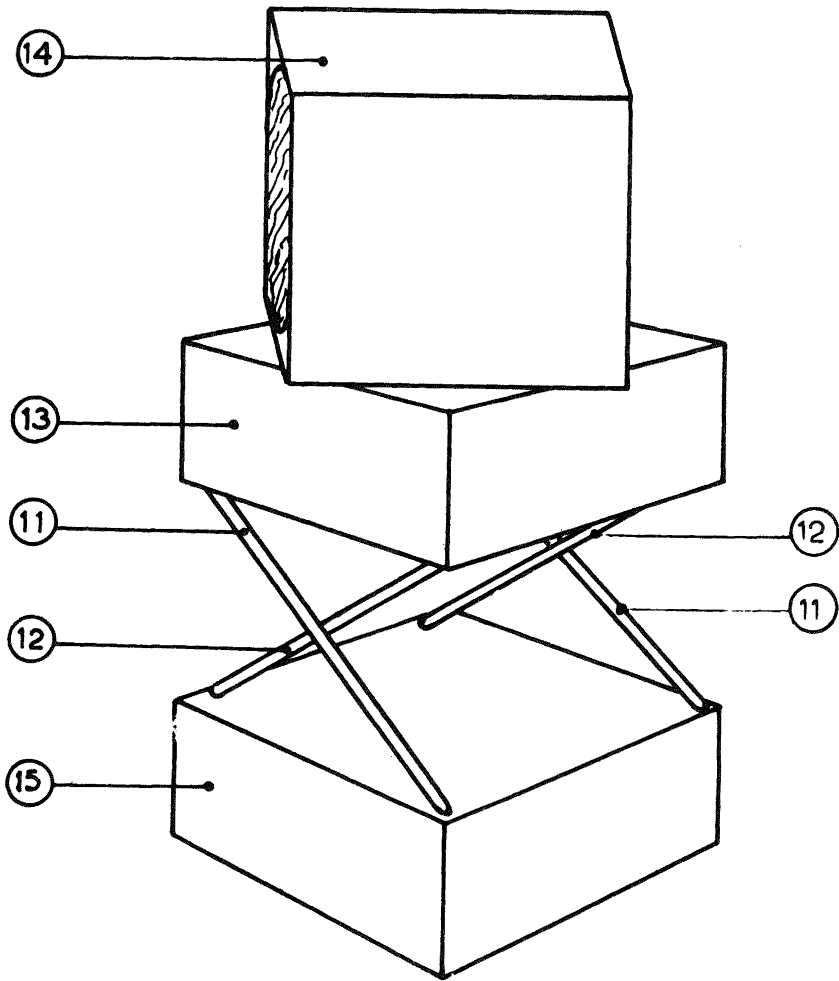

Fig.2 (b): Accelerometer

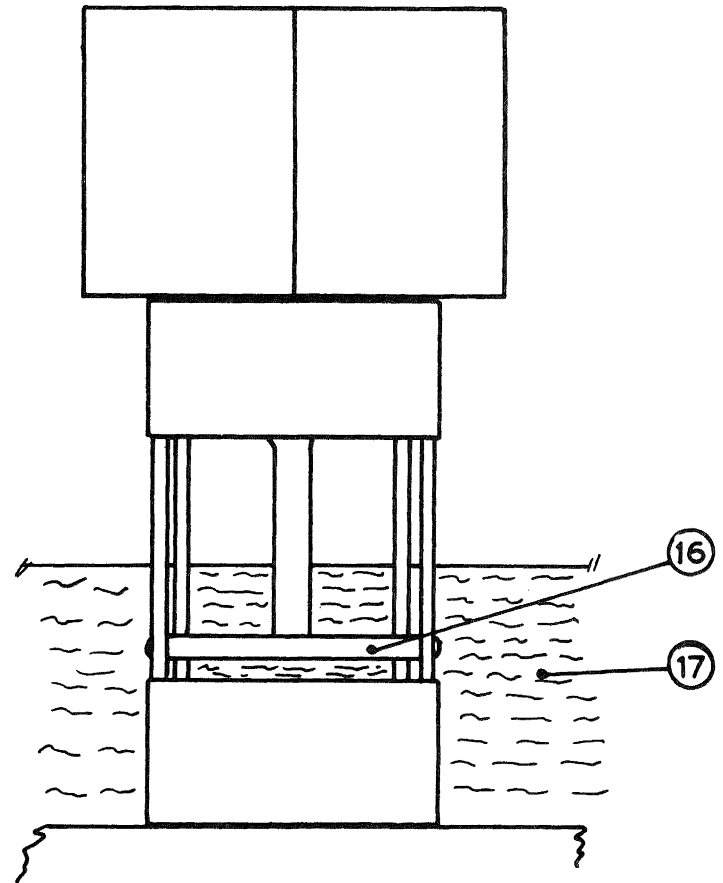

Fig.2 (c): Damping method

### Calibration Data

Instrument Number: 66

Date: 28th November 1967

Control Circuit Board: 130

Duration of run: 42.4

Inverse Sensitivity — Accelerometer Block: 130

$$I_a = 0.625 \quad \text{g/cm}$$

$$I_b = 0.660 \quad \text{g/cm}$$

$$I_c = 0.401 \quad \text{g/cm}$$

### Deviations of Sensitivity Axes from Nominal Directions —

radians

degrees

$$\alpha_z = 0.032 \quad = \quad 1.9$$

$$\alpha_y = -0.009 \quad = \quad -0.5$$

$$\beta_x = 0.007 \quad = \quad 0.4$$

$$\beta_z = 0.023 \quad = \quad 1.3$$

$$\gamma_x = -0.010 \quad = \quad -0.6$$

$$\gamma_y = -0.019 \quad = \quad -1.1$$

**Note:** The direction of the axis of the installed instrument must be measured.

Fig. 3(a): Calibration data supplied with each instrument

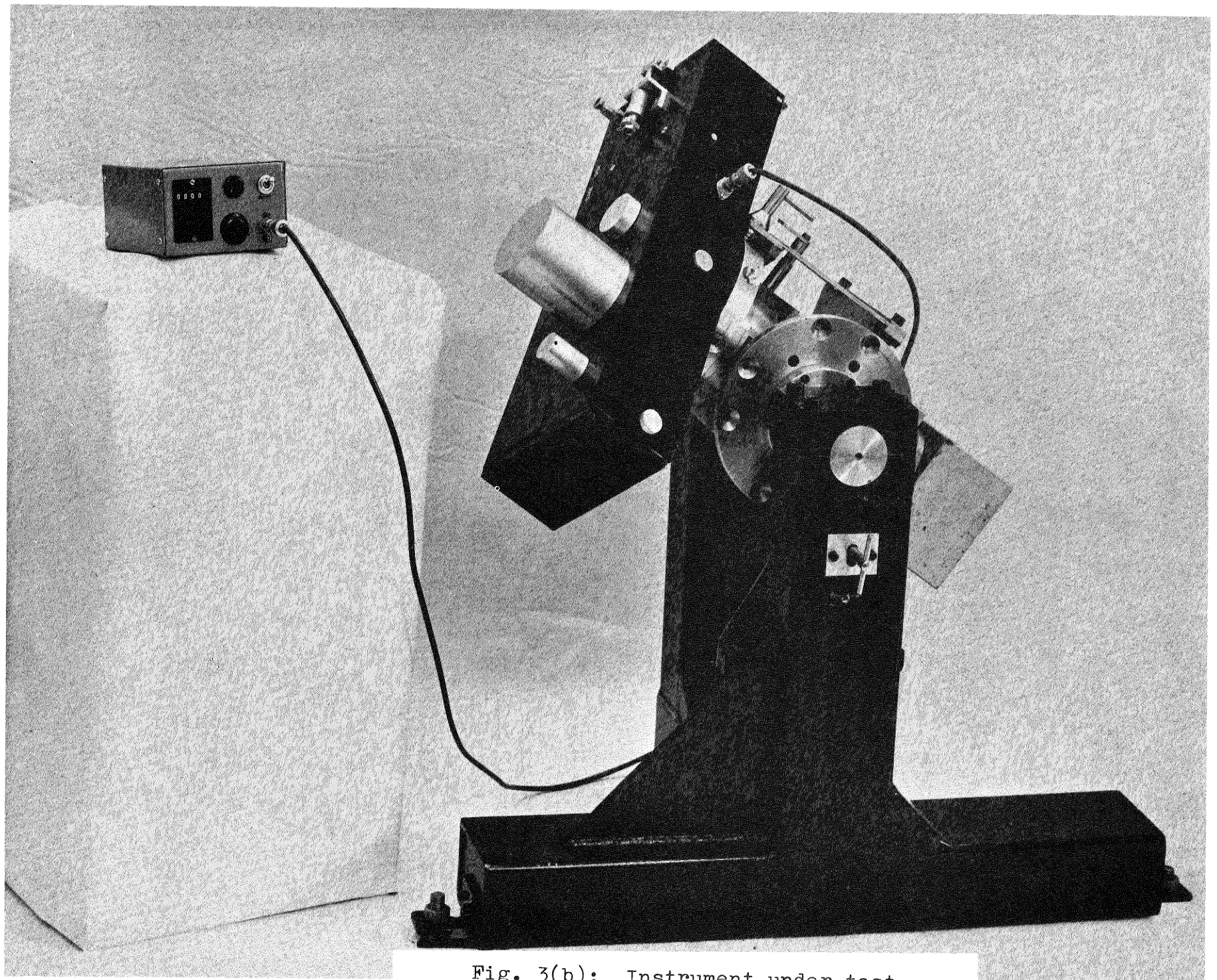

Fig. 3(b): Instrument under test

Accessories: The following items are available as accessories:-

Re-chargeable Globe RP6261 Battery or Non-Rechargeable  
Mallory-Mercury Battery No. 303232.

Film - 35 mm unperforated, Ilford FP3, Photographic  
Film.

Aluminium Mounting Bracket.

Manufacturer: Victoria Engineering Ltd.,  
P.O. Box 30315,  
Lower Hutt.

N.Z. Distributor:

Forgan Jones Limited,  
P.O. Box 9197,  
Newmarket,  
Auckland.

## 5. Description of Installation

Accelerographs are usually located on 3 levels: one installed at the top, one at mid-height and one (the master) in the basement of the building. It is desirable, so far as possible, to locate the upper two instruments at a point on their respective floor levels which will give a representative oscillation pattern for the building. In all cases, the 3 instruments should be located in an area which is protected from shock, other than due to earthquake, from handling by unauthorized persons, and where it will not be damaged by in-falling panels, goods or fixtures during an earthquake. The cover box is padlocked and is marked "Earthquake Recording Instrument". The instrument must be accessible for servicing, testing and inspection by the Department of Scientific & Industrial Research, who hold master keys for all instruments. Two keys are supplied to owner.

The minimum space for each instrument installation should be about 6ft x 6ft x 4ft high ( a slightly larger space is preferred if available), but surrounding area may be used for other purposes which will not be detrimental to the instrument.

Each Accelerograph must be securely anchored to the concrete floor, main beam or column system. See Figs. 4, 5, and 6, for typical floor, corbel and bracket mounting details.

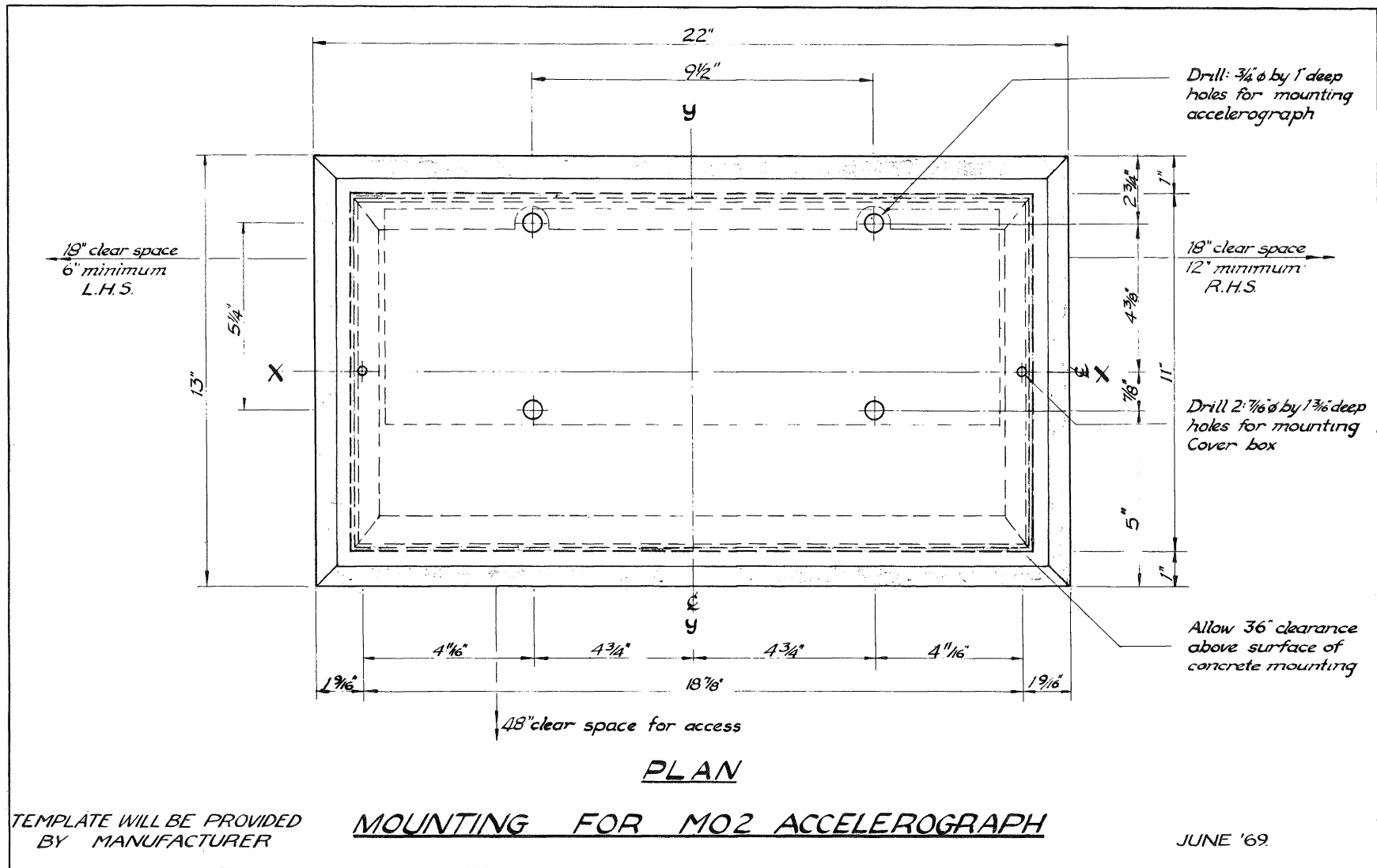

Fig. 4.

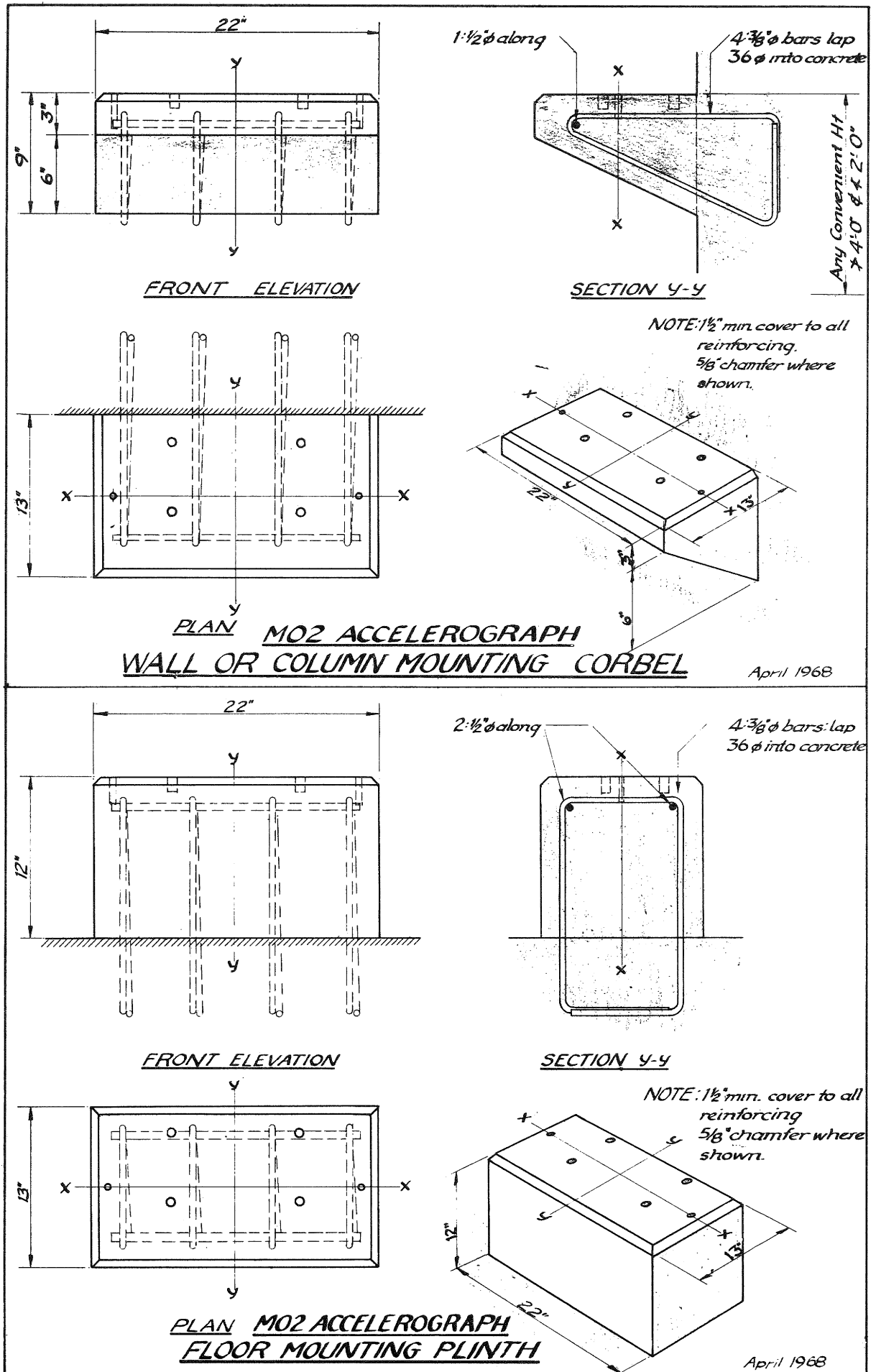

Fig. 5

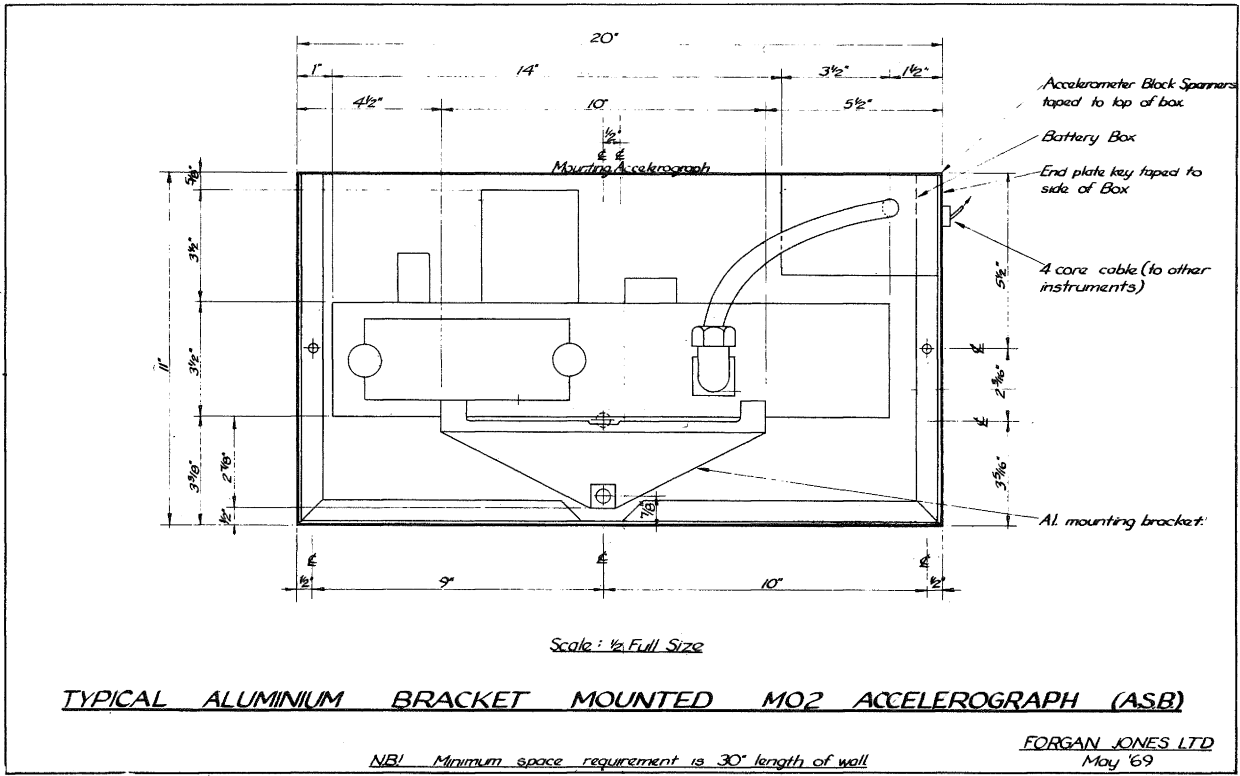

Fig. 6

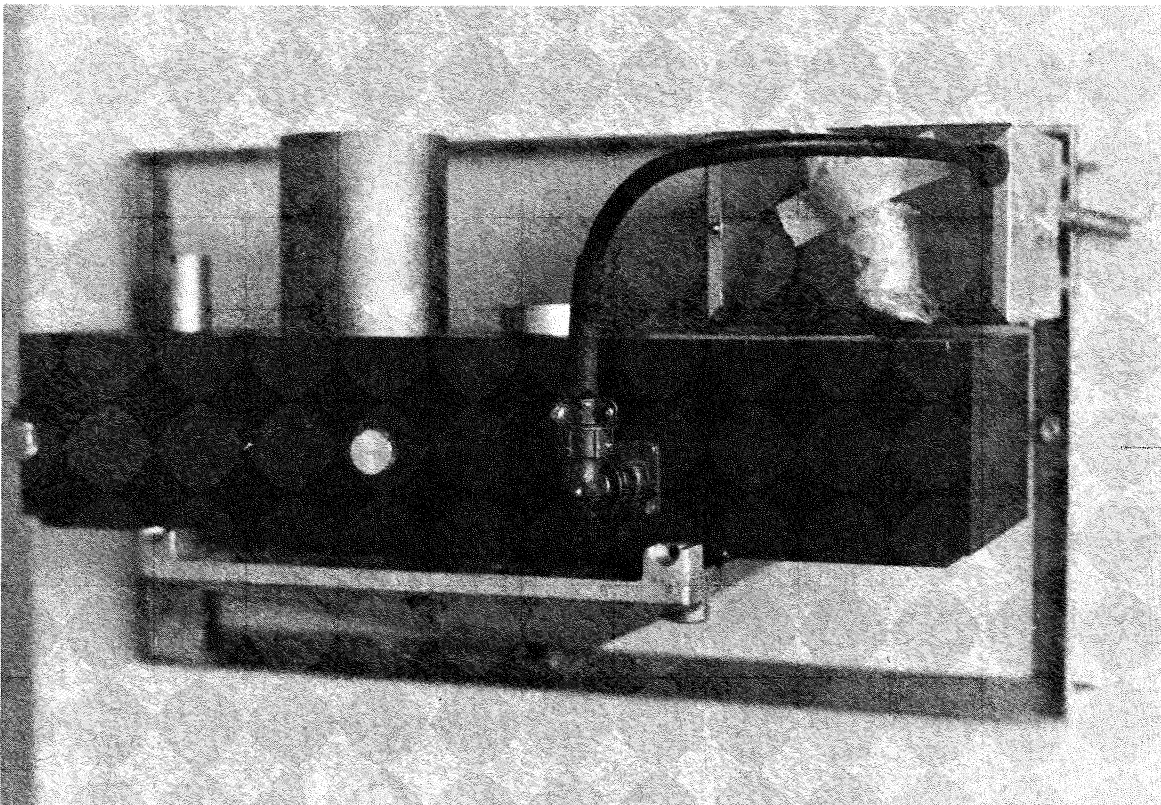

Fig. 7: Aluminium Bracket Mounting

Fig. 7 shows a typical aluminium bracket mounted instrument (A.S.B. Auckland). It is emphasised that the instrument is designed for floor mounting and this is the recommended method. With the aluminium mounting bracket the single 3/8"Ø bolt penetrates to a depth of 2" into the concrete. If possible, the Accelerograph should be positioned in a North-South, East-West plane, unless building design or other factors dictate otherwise.

The 3 Accelerographs should be electrically connected to ensure that all 3 start simultaneously in response to an earthquake. For this purpose, it is necessary to provide a 4-core cable connection between the 3 instruments. This cable which is approximately 1/4" diameter, should be protected within a duct or conduit to avoid damage, since it carries only low amperage 12 VDC current. It is not affected by adjacent AC cabling. Each instrument is equipped with a separate battery to obviate additional wiring complications. Moreover, as wiring circuits may be disrupted in a major earthquake, each instrument with its own battery ensures reliability of performance.

In the case of some important engineering structures such as large bridges, it is desirable to have an instrument mounted at ground level close to each abutment to measure ground movements adjacent to the structure. External ground measuring instruments outside a building, but connected to the internal instruments, are also considered desirable, since building foundation interaction will disguise to some extent, the actual ground motion attacking the building and an instrument located in the basement may not necessarily be recording actual ground motion.

## 6. Pricing

A typical 3 unit installation comprises:-

One (1) Master Instrument, i.e. with Time Marking Device	\$1,100.00 each
Two (2) Slave Instruments at \$1,000.00	\$2,000.00
Supply and running of inter-instrument - 4-core cabling, instrument installation and testing, approx.	\$ 500.00
Total Approx. Cost	<u><u>\$3,600.00</u></u>

A fourth master unit located external to the main structure, for recording actual ground motions would be priced at \$1,100 plus cost of cabling and mounting.

## 7. Interpretation of Accelerograph Records

The Accelerogram is a record of acceleration vs time. From it the following information can be deduced:-

1. Plots of both the velocity and displacement vs time.
2. The maximum accelerations, velocities and displacements that occurred in the structure at the accelerograph stations.
3. The accelerograph located in the basement of a structure measures the accelerations of the foundation. A time dependent mathematical analysis can be made using the foundation movements at the base. These motions are then related to the measured values at the accelerograph levels above the ground. Thus, a time-history of each floor displacement may be derived.
4. Response spectra.
5. A set of three structural and one ground accelerograph, besides providing a basis for calculating response spectra and assigning damping can tell how much each resonant mode participated.

### Mathematical Analysis Information.

The accuracy of information obtained from the mathematical analysis depends on how sophisticated the analysis is. Accurate structural information about the building is essential. An accurate assumption of unknown coefficients (damping), based on experience gained through testing, is essential. For a standard, elastic, time-dependent analysis, the responses (stresses, deflections, etc.) predicted will be fairly accurate provided none of the stresses in the structural members exceed their proportional limit. In most strong earthquakes, however, the stress levels in the structural members exceed their proportional limit, and the validity of an elastic analysis lies only in the fact that it indicates where yielding is most likely to have occurred. In these cases, a more sophisticated elasto/plastic analysis is necessary to accurately predict the responses of the structure.

### The Response Spectrum:

A response spectrum is a plot of the absolute maximum responses (displacement, velocity and acceleration) for different natural periods of vibration and damping of a single, degree-of-freedom oscillator to a specified input motion.

Damping characteristics of the structure influence the amplitude of response to different frequencies of earthquake vibration, and each earthquake will differ in character with certain frequencies dominating.

Response spectra for various earthquakes are, therefore, plotted as families of curves, representing different values of damping as experienced at the various accelerograph sites, and as interpolated for other parts of the structure.

Comparison of the response spectra so obtained, with computed spectra for systems with a single degree-of-freedom are valuable in terms of ultimate improvement in structural design methods.

Typical accelerogram records obtained from the Wellington earthquake on 1st November 1968 are shown at Fig. 8.

Since the value of the interpretation of the instrument records depends upon accurate structural information, it is essential that "as built" drawings, calculations and specifications should be retained by the building owner, his professional advisers or other approved authorities in a place of safe custody, for the whole life of the building.

These records should be made available only to approved scientific authorities, for the purpose of conducting the analysis and interpretation of the records.

## **8. Reasons for Installing Accelerographs In Buildings and Civil Engineering Structures**

### Value to Owner:

Buildings and large structures in the known seismic regions of the world can be expected to experience several earthquakes during their useful lives. These earthquakes will normally be random in magnitude with few, if any, sufficiently strong to cause a building to collapse. However, one or several moderately strong earthquakes may cause excessive stressing of some elements of the structure which could ultimately result in the failure of key members of the structure.

WELLINGTON EARTHQUAKE 1 NOVEMBER 1968.

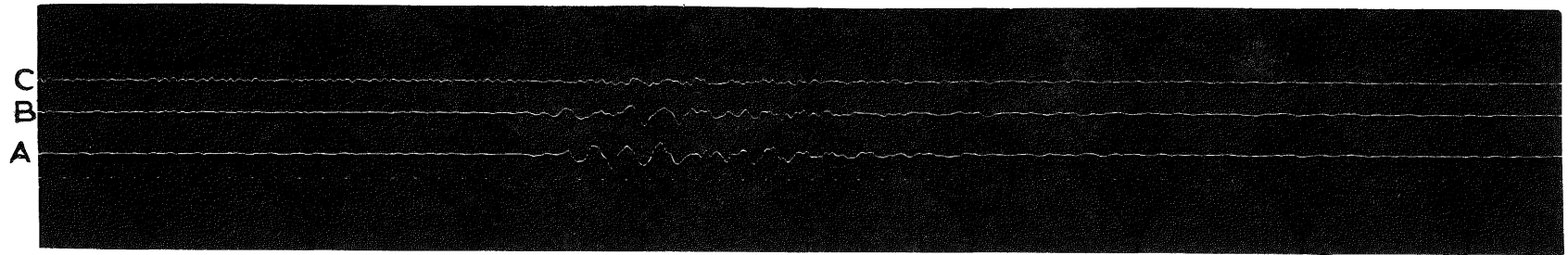

HAYWARDS      A    225°      B    135°      C    Vertical.  
                          1.72 cm/g      1.81 cm/g      2.55 cm/g  
                          1g                    1g                    1g

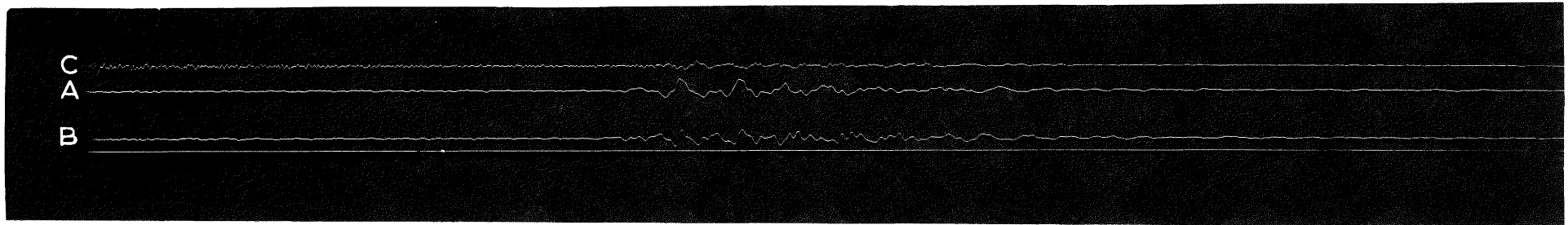

P.E.L.            A    345°      B    255°      C    Vertical.  
                          1.63 cm/g      1.66 cm/g      2.31 cm/g  
                          1g                    1g                    1g

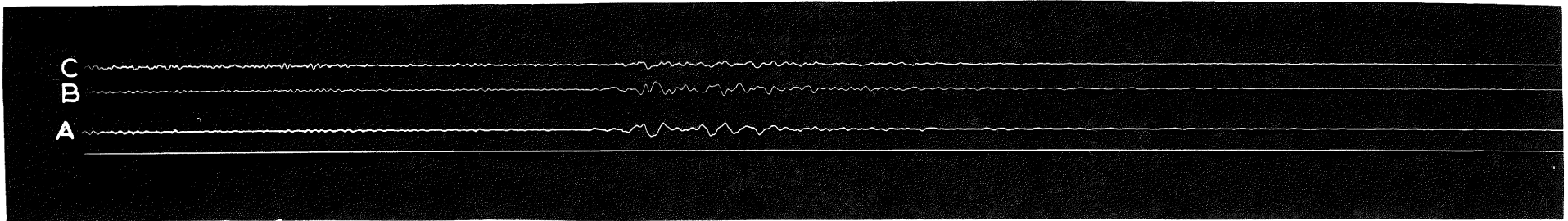

INS                A    99°      B    9°      C    Vertical  
                          1.60 cm/g      1.51 cm/g      2.31 cm/g  
                          1g                    1g                    1g

Fig.8: Accelerograms - Wellington Earthquake, 1 November 1968

The strong motion accelerograph is a means by which the building owner, through his Consulting Engineer and with the aid of the Department of Scientific & Industrial Research, can continuously monitor the performance of the building as it experiences earthquake motion.

After an earthquake, the intensity of motion at a building location will, of course, determine how the building is affected. If the accelerograph were not actuated, then the maximum accelerations were below that required to actuate the equipment, and little superficial damage would be expected. The next level of excitation is that which actuates the instrument, but a visual inspection of which indicates small accelerations. If the accelerations recorded on the instrument indicate that the design base shear has not been exceeded, it can usually be assumed that there will be little or no structural damage although there may be some superficial damage evident, e.g. plaster cracking, etc. In both of these cases, the owner may be immediately advised that his building is safe.

If the accelerations are large, then a more sophisticated analysis will be necessary. Considerable information will be obtained about the building's performance from the mathematical analysis of the accelerograph records. The evaluation of this information may indicate that no damage was incurred; thus, saving the expense of a detailed structural engineering survey.

If the building should be structurally damaged, then a further analysis should be performed to isolate the suspected area before removing partitions, plaster, etc., in order that the Engineer may determine the extent of the total damage and make a decision with respect to the remedial work required.

This final analysis would involve considerably less cost than exposing large parts of the frame for visual inspection.

Obviously, people occupying or using large and important structures will have fewer reservations about returning to the building if they are aware of the extent to which the structure's performance was monitored.

Value to the Community:

The data obtained from accelerograph records can also be used by Scientists and Engineers in the development of more refined Earthquake Resistant Building Codes and design techniques.

The concentration of large buildings in cities, housing many people or large civil engineering structures providing vital public amenities, makes it imperative that there be a better understanding by Engineers of the nature of earthquakes, and the way such structures react. Only by studying many records from many different types of construction on many different types of foundations can better design requirements and techniques be developed.

#### Accelerograph Ordinances:

The reduction in cost of monitoring large areas, due to the development of the economically priced M.O.2, made it possible for Californian Building Authorities like the cities of Los Angeles, Beverley Hills, Berkeley and various counties in that state, to adopt mandatory accelerograph installation ordinances. Moreover, proposals for strong motion recording instruments in all areas classified Seismic Zone 3 in the United States are now being carefully examined. These Building Codes require the installation of three accelerographs in certain new high-rise buildings (vide City of Los Angeles Ordinance No. 129,237), the instruments being required on the ground floor (or basement), mid-height and top floor. The equipment is purchased by the building owner. Following the introduction of these Ordinances, the number of accelerograph installations in U.S.A. amounts to about 300, of which approximately 200 are in the Southern Californian area, primarily due to the ordinance requirements introduced in 1966.

Similar requirements now exist in Mexico City, Caracas, Venezuela, Lima (Peru).

The Japanese Government actively supports the installation of accelerographs and there are perhaps 300 such installations in Japan.

In New Zealand, the installation is maintained, tested, read and interpreted by the D.S.I.R. The records are released by P.E.L. only to the building owner, bona fide research workers or the structural engineer who was directly responsible for the design of the building, and no others. This clearly enunciated policy avoids any use of the records which could be detrimental to the interests of Consulting Engineers.

In the light of the experience gained in these earthquake prone areas, there seems to be a very strong case for similar provisions to be written into N.Z. Building Codes. The N.Z.

Ministry of Works have provided a positive lead, by recommending to their client departments, that earthquake recording instruments be installed in buildings of appropriate size (vide PW 81/10/1:1968, Design of Public Buildings, Para 6.10).

A schedule of N.Z. accelerograph installations in N.Z. is set out in Appendix A. The very limited number of instruments deployed throughout the country falls far short of that required to carry out effective blanket monitoring. The small number of instruments installed in Wellington City is of particular concern when related to the large number of high rise buildings recently erected in that city. Wellington City is in the highest seismic risk zone, has an established record of relatively severe earthquake activity and, despite the fact that on almost every one of these high rise building projects a recommendation for earthquake instrumentation has been made by the Structural Engineer concerned to the owner, there are very few installations. State-owned buildings are not exempt from this criticism.

One eminent authority on earthquake research has publically stated - "Earthquake research is something which cannot be left to public opinion or the layman".

## 9. Appendix A.

N.Z. Installations (As at 31 July 1969):

<u>Owner</u>	<u>Installed At</u>	<u>No. Of Instruments</u>
Wright, stephenson & Co. Ltd.	Wright Stephenson H.O. Building, Lambton Quay, Wellington.	4
N.Z. Electricity Dept.	Haywards Substation	1
University of Canterbury	School of Engineering, Christchurch	3
Auckland Savings Bank	Auckland Savings Bank, H.O. Building, Queen Street, Auckland	3
Ministry of Works	Vogel Building	4
Post & Telegraph Dept.	Postal Centre, Jervois Quay, Wellington	4

Ministry of Works	Proposed Nuclear Power Station Site, Kaipara Harbour, Auckland	2
D.S.I.R.	Wellington Microzoning	5
Auckland University	Science Building, Symonds Street, Auckland	5
Auckland City Council	A.C.C. Administration Bldg, Civic Centre, Auckland	6
Ministry of Works	Benmore Hydro-Electric Dam	7
Ministry of Works	Matahina Hydro-Electric Dam	5
Ministry of Works	Proposed Wanganui Power Development Project, Atene	6

## 10. Acknowledgements

The writer extends his thanks to the Director, Physics and Engineering Laboratory, D.S.I.R. and to the Managing Director, Victoria Engineering Ltd. for their ready assistance, guidance and help in preparing this paper.

## 11. Editorial Footnote .

Mr G. K. Bunce B.E., M.N.Z.I.E., was invited to write this paper because information about strong motion earthquake recording instruments was not available generally to New Zealand practitioners; and as the management committee of the Society had received requests from architects and engineers to present information in the Bulletin. The type M.O.2. instrument is the only strong motion earthquake recorder manufactured in New Zealand; and has appeared as a cooperative venture of Government and private enterprise. In this special circumstance, and in view of the importance of the subject, the committee has considered that there is no impropriety in including relevant information of the manufacturer's specification and pricing.