

REVIEW OF RECENTLY CONSTRUCTED CONCRETE WALL- STEEL FRAME HYBRID BUILDINGS

Claire Pascua¹, Rick Henry² and Charlotte Toma³

(Submitted *March 2022*; Reviewed *April 2022*; Accepted *August 2022*)

ABSTRACT

Around New Zealand there has been an increasing trend of ‘hybrid’ multi-storey buildings that combine reinforced concrete walls with structural steel framing systems. This study aims to characterise and understand this type of building, focusing on buildings constructed in Auckland and Christchurch from 2014 onwards. Drawings from a total of 50 buildings were reviewed, and their structural features were documented, including building use, building height, lateral load resisting system, ductility, wall configuration, wall construction method, steel framing system and suspended floor system. Meetings with structural engineers were conducted to validate the review findings and to further understand design principles and decisions that lead to these outcomes. A typology comprising five building types with distinct lateral load-resisting systems was proposed based on the building review. Results showed regional differences between Auckland and Christchurch, owing to building use and seismic hazard in the respective cities. Auckland buildings surveyed tended to be residential buildings five storeys or higher made of precast walls connected with steel beams. Christchurch buildings, on the other hand, were primarily commercial buildings three to seven storeys high with dual frame-wall systems. Structural connections between steel frames and concrete walls were also documented, showing that bolted connections with headed stud embedment were most common. The results can be used to identify critical aspects of these mixed structural systems for further investigation and to develop archetype building designs that can be used for modelling and testing.

<https://doi.org/10.5459/bnzsee.1602>

INTRODUCTION

In recent years, hybrid buildings that combine concrete walls and steel frames have become a popular choice for commercial and residential buildings in New Zealand. Structural steel has become an increasingly common choice for structural systems due to availability, price, speed of construction, and post-earthquake reparability [1]. Its weight-to-strength ratio also makes it suitable for specific soil conditions. However, concrete walls continue to be used for the lateral load resisting system in many buildings due to their strength and stiffness, with the added advantage of built-in fire rating and insulation, and functional use for access/services, cores, and property boundaries.

It should be noted that in this paper, “hybrid building” refers to any building that use a combination of concrete walls (both precast and in-situ) and steel beams or steel frames as part of the gravity system and/or lateral load-resisting system. On the other hand, a “dual system” uses two different lateral load resisting systems in parallel. A dual system can therefore be a subset of hybrid buildings if different structural materials are used.

A study conducted by Bruneau and MacRae [1] describes how construction practice in Christchurch moved toward the dominant use of structural steel during the rebuild following the 2010/11 Canterbury earthquakes. Despite this paradigm shift, 35% of the Christchurch buildings constructed post-earthquake used concrete walls as the primary lateral load resisting system combined with steel framing systems. Similar trends have been observed in Auckland, with many new buildings using precast concrete walls with steel gravity beams and frames. Despite the growing number of such hybrid buildings constructed in New Zealand, the seismic performance of this building type has not been extensively investigated. Current structural design

standards are compartmentalised into materials and do not explicitly address the design of buildings with mixed-material structural systems [2,3].

Existing international research on concrete wall-steel frame hybrid structures focuses on high-rise or super high-rise buildings [4–7], whereas New Zealand buildings are typically low- to medium-rise. The widespread use of precast floors in New Zealand poses additional questions regarding the seismic performance of diaphragms in such mixed-material and dual-system buildings. There is also little research on concrete wall-steel frame connections, with existing research focusing only on the performance of connections between steel gravity frames and concrete core walls [8–11].

Given the lack of research and literature, especially in the New Zealand context, it is crucial to investigate this emerging form of concrete wall-steel frame hybrid buildings to ensure that they will behave as intended by design. However, doing so first requires an understanding of the current state of practice. The aim of this study was to characterise recently constructed buildings in New Zealand that combine structural steel frames and concrete walls by undertaking a review of structural designs and developing typologies to categorise buildings with similar structural features.

LITERATURE REVIEW

Concrete Wall-Steel Frame Hybrid Buildings

The practice of combining concrete walls with steel frames is considered an attractive and economical building solution in high seismicity areas in the USA and China [4,6,7,9,10,12,13]. Typically, concrete core walls are used together with outer steel frames, as shown in Figure 1.

¹ Corresponding Author, PhD Candidate, The University of Auckland, Auckland, mpas592@aucklanduni.ac.nz (Student Member)

² Associate Professor, The University of Auckland, Auckland, rs.henry@auckland.ac.nz (Member)

³ Lecturer, The University of Auckland, Auckland, charlotte.toma@auckland.ac.nz (Member)

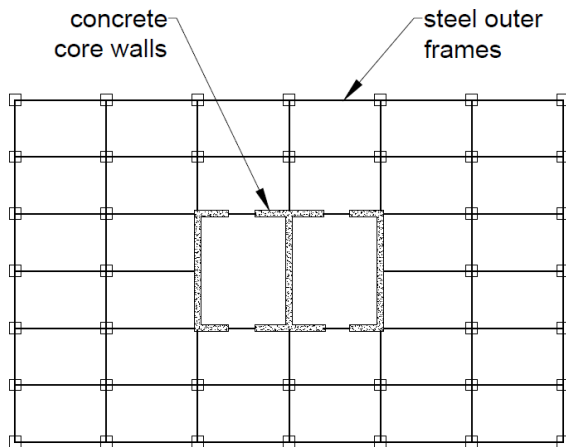

Figure 1: Example floor plan of a mixed-material building with concrete core walls and outer steel frames.

Where concrete walls provide lateral stiffness and deformation control in the lower storeys, steel frames provide added energy dissipation and deformation control for upper storeys [12]. The interaction between concrete walls and steel frames also allows for reduced steel member sizes resulting in larger floor areas, reduced self-weight, quicker construction time, and economic savings [1,4,9,12,13].

Studies on mixed-material hybrid buildings started as early as the 1980s when Hawkins et al. [8] performed tests on welded end plate connections between steel beams and concrete columns, as shown in Figure 2. Several test variables were investigated, such as stud spacing, edge distance, plate sizes and stud embedment lengths. It was found that this form of connection can transfer shear and moment, but the moment capacity was controlled by the tensile capacity of the studs. High moment demands resulted in brittle failure, particularly when the studs were not deeply embedded. Hawkins et al. [8] suggested that until further studies were conducted, such connections should be designed conservatively by adding more

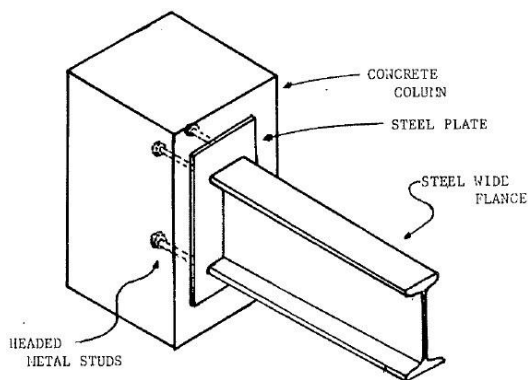

Figure 2: Concrete column to steel beam welded end plate connection [8].

tensile studs.

Roeder and Hawkins [9] further investigated concrete wall-steel frame connections by modelling several prototype structures with RC core walls and outer steel gravity frames and examining different geometries and connection conditions (i.e. pinned and moment-resisting). It was established that pinned connections were preferable due to their potential to fail in a ductile manner. Roeder and Hawkins [9] then conducted experimental tests on bolted web plate connections, as shown in Figure 3. These bolted connections consist of a web plate

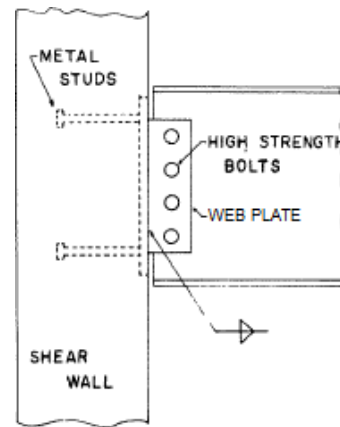

Figure 3: Concrete column to steel beam bolted web plate connection [9].

welded onto an endplate, which is embedded onto the wall with headed studs. Though commonly assumed to be pinned, these connections still develop significant moments due to friction and bearing on the bolts [14]. A design procedure was proposed to ensure ductility of the connection, where the studs are designed for 1.5 times the original moment and shear demands. Though the experiment results validated this design approach, it was found that inelastic cyclic loading caused significant strength degradation in the connections.

In 2004, Shahrooz, Deason, et al. [10] tested bolted web plate beam-to-wall connections for a 15-storey prototype building with perimeter steel gravity frames and a central reinforced concrete (RC) core wall. A design methodology was proposed to ensure yielding of the web plate to avoid brittle failure in the connections, which was successfully validated using the test results. Ductile failure of the web plate through yielding was attained, and the walls around the connection did not experience cracking or damage. Moreover, the specimen designed using the proposed methodology had twice the tensile capacity of other specimens based on then-standard design methods, thus requiring fewer studs. Shahrooz, Tunc, et al. [11] also attempted to quantify the connection capacity in terms of wall drift, which is a critical design parameter. Tests were conducted on sub-assemblies consisting of a concrete wall with two steel beams and a portion of the slab. It was found that despite significant damage to the walls (e.g., spalling, longitudinal bar yielding), the connection capacity could still exceed design loads. Wall boundary elements also increased stud capacity by providing confinement and preventing pull-out failure.

In China, dual systems consisting of steel perimeter frames and central RC core walls are extensively used in high-rise and super high-rise buildings such as the LG Twin Towers shown in Figure 4 and the Fortune Financial Centre shown in Figure 5. The increase in number of such mixed-material buildings prompted several studies including connection tests, numerical analyses and small-scale (1:20) shake table tests [4–7,15]. There is a consensus that even with major wall damage at lower storeys, the dual concrete wall-steel frame system demonstrated good seismic capacity and deformation capacity in all buildings, provided the connections between core walls and surrounding elements were adequately detailed. In Liu and Zhou [6]’s study, proposed semi-rigid connections showed a good compromise between pinned and moment-resisting connections for high-rise concrete wall-steel frame buildings, providing good strength, ductility and energy dissipation. Zhou and Li [7] also acknowledged possible uncertainties relating to composite floor actions and connection performance due to the scale of the shake table tests.

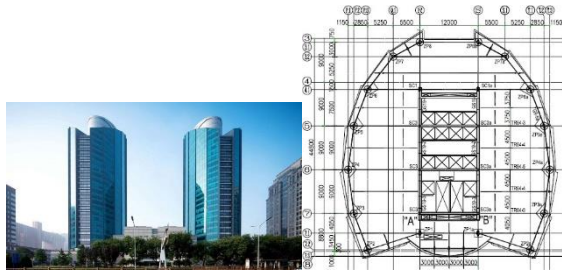

Figure 4: The LG Twin Towers in Beijing, China is a 31-storey building comprised of an RC core tube and steel outer frames. (Photo: GIC [16], Floor plan: Hou et al. [4])

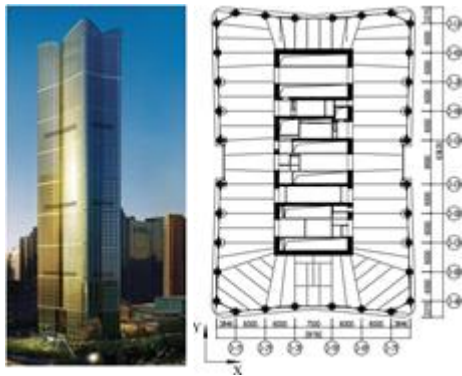

Figure 5: The Fortune Financial Centre in Beijing, China is a 61-storey office building with an RC core tube and steel outerframes. (Photo and floor plan: Jiang et al. [5])

New Zealand Construction Practice

Bruneau and MacRae [1] described and quantified a paradigm shift in construction practice observed in the Christchurch rebuild following the 2010-2011 Canterbury earthquakes. The study involved a review and documentation of structural drawings of 74 buildings in the Christchurch Central Business District (CBD), which comprise 60% of post-earthquake reconstructed buildings consented for the area between February 2011 and March 2017. This was followed by a series of interviews and workshops with structural engineers and other stakeholders (e.g. project manager, architect, and developer). Findings showed that Christchurch construction trends have moved from the dominant use of RC buildings towards structural steel for a variety of reasons including speed of construction, improved workmanship due to computer-controlled fabrication, and relatively lower prices of steel compared to previous years. Furthermore, in the post-earthquake environment in Christchurch, factors such as reparability and easier on-site quality assurance and damage identification also make steel an attractive choice. Lastly, the high strength-to-weight ratio of steel reduces building self-weight, which is favourable for poor soil conditions prevalent in Christchurch.

Despite the increased use of structural steel for structural framing, Bruneau and MacRae [1] found that 44% of the total number of buildings in the Christchurch rebuild used RC walls as the primary lateral load resisting system, with RC walls particularly prevalent in smaller scale buildings. It was also noted that most buildings with RC walls were combined with steel framing systems, such as the examples shown in Figures 6 and 7. According to many of the engineers interviewed during the study, RC walls can provide good seismic performance alongside functional uses. Especially for low-rise buildings that required fire rating between property boundaries, RC walls



Figure 6: A five-storey commercial building in Christchurch with steel gravity frames, core and perimeter concrete walls, and an internal eccentrically-braced frame. (Photo: Bruneau and MacRae [1])



Figure 7: A three-storey retail building in Christchurch with steel moment-resisting frames and perimeter walls acting as a dual system.

designed for lower ductility response were a good solution. In particular, one engineering firm interviewed during the study found that for their projects, RC walls resulted in overall lower building costs as braced frames require fire protection and insulation [1]. While this may not be true for all buildings, it appears applicable to certain cases.

It is interesting that RC walls remain a common choice of structural system despite the performance of buildings in the 2010/2011 Canterbury earthquakes highlighting a range of potential design issues with RC walls [17]. This is attributed to a combination of extensive research that has resulted in improved design provisions for RC walls [18], as well as engineers using walls to achieve stiffer buildings with lower drift demands to minimise damage to both structural and non-structural components.

The combined advantages of RC walls and steel framing systems has given rise to concrete wall-steel frame hybrid buildings. Bruneau and MacRae [1] found that 75% of the buildings with RC walls as the primary lateral load resisting system used steel frames instead of RC frames, equating to 35% of the total number of buildings in the study. The authors also remarked that even before the 2010/2011 Canterbury earthquakes, a similar construction trend had been observed in Auckland. Recent examples of Auckland buildings that use such mixed-material structural systems are shown in Figures 8 and 9.

Some, but not all, of the interviewees in Bruneau and MacRae [1]'s study speculated that concrete wall-steel frame buildings could be the future of multi-occupancy residential buildings in Christchurch. This is because concrete walls do not require further fire-rating or acoustic insulation, and they allow for lower storey heights, resulting in faster and more economical construction. As construction in Christchurch was starting to shift from commercial to residential, concrete wall-steel frame hybrid buildings will likely be observed more frequently in the coming years.

BUILDING SURVEY



Figure 8: A hotel building in Auckland that utilises RC walls with steel gravity frames.



Figure 9: A hotel building in Auckland with a combined RC core with eccentrically-braced steel frames.

Building Typologies

Developing a building typology is a necessary exercise in the seismic performance assessment of a building stock. It involves categorising buildings into several types with similar features and layouts, which can be used to develop representative model buildings (also known as archetypes). It is challenging to study every individual building in a specific region, so defining typologies can narrow the scope into a handful of representative archetypes that can be studied in detail.

A building typology is generally developed by surveying or observing a building stock, understanding its structural features, and identifying parameters that influence seismic performance [19-23]. Typical building typology parameters include occupancy, building height, construction material, structural system, lateral load resisting system, roof system, flooring system, building age, and seismic design level [24-27]. These parameters are defined according to the local building practices for which the seismic performance assessment is carried out. Parameters can also be customised when investigating a specific building stock. For example, a study by Fikri et al. [19] indicated wall material and wall morphology as the relevant typology parameters for the seismic performance of unreinforced masonry buildings. Though these parameters are not commonly found in other generic typologies, it was deemed most applicable for that specific structural system.

Data Collection

A review of structural design features of recently constructed multi-storey buildings in Auckland and Christchurch was undertaken to understand the current state of practice for concrete wall-steel frame buildings in New Zealand. Auckland and Christchurch were selected as study areas due to significant construction activity in these cities.

An initial list of buildings was developed through desktop research, sidewalk surveys, and discussions with engineers. Structural drawings were obtained from council property files and structural engineers. The drawings were examined to confirm that the buildings fit the following study criteria:

1. Buildings located in either Christchurch or Auckland.
2. Recently constructed (defined as 2014 onwards).
3. Structural concrete walls formed part of the lateral load resisting system.
4. Structural steel frames or beams formed part of either the lateral or gravity load resisting systems.

Overall, 50 buildings were included in the database, comprising 28 in Christchurch and 22 in Auckland. The buildings were designed by 18 different structural engineering firms, indicating that combining steel frames with concrete walls is becoming a trend, rather than just a practice limited to a few engineering firms.

The structural drawings were reviewed, and significant structural features relevant to seismic performance were identified. These features included building use, building height (number of storeys), importance level, lateral load resisting system, design ductility, type of steel framing system, wall construction method, wall configuration, type of suspended floor system, and any unique design features (e.g. low-damage solutions). Data were aggregated by city to determine regional differences in concrete wall-steel frame building trends between Christchurch and Auckland, representing two distinctly different geographic regions and seismic hazards.

Following the building survey, meetings were conducted with three structural engineering firms based in Christchurch and another three in Auckland to examine the design philosophies further and validate observations from the building survey. The three Christchurch firms designed 16 of the surveyed Christchurch buildings, and the three Auckland firms designed 10 of the surveyed Auckland buildings.

Structural Features of Surveyed Buildings

The collated data from the building survey aggregated by city is plotted in Figure 10. The features summarised include building use, building height, importance level, lateral load resisting system, design ductility, steel framing system, wall construction, wall configuration, and suspended floor system.

A wide variety of building use was observed, with distinct differences between Auckland and Christchurch, as shown in Figure 10a. A total of 90% of the surveyed Auckland buildings were communal residential use (e.g. apartments, hotels, retirement homes). In Christchurch, 70% of the surveyed buildings were commercial use (e.g. offices, retail, car parks), only 20% served communal non-residential use (e.g. schools, universities, hospitals), and only 10% were communal residential use. However, this regional trend is not unique to concrete wall-steel frame buildings, but reflects the construction demands in each city with the Christchurch rebuild focused on commercial buildings in the CBD and higher demand for multi-unit residential buildings in Auckland [28].

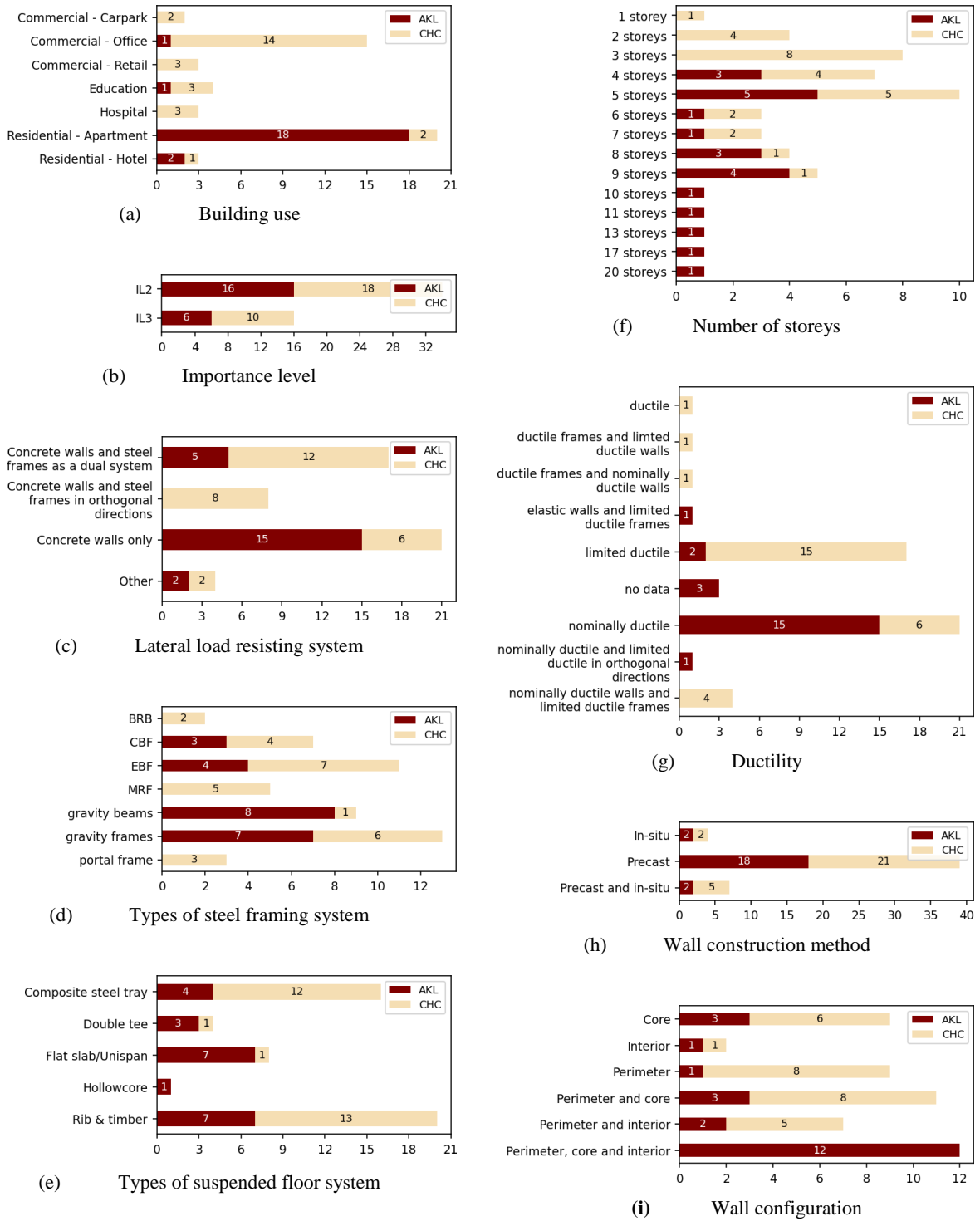

Figure 10: Summary of building structural features.

As for importance level, Figure 10b shows that the surveyed buildings were approximately two-thirds IL2 and one-third IL3.

Figure 10f shows that 60% of the surveyed buildings in Christchurch were three to five storeys high, and 75% were three to seven storeys high. This can be attributed to the Christchurch District Plan implemented post-earthquake, which indicates maximum building heights anywhere between 8m to 28m depending on the location [29], in addition to economic drivers for development based on land values in Christchurch. On the other hand, Auckland buildings were taller, with 90% being five storeys and above and 60% being eight storeys and above. This can be attributed to the Auckland Unitary Plan,

which enables construction of taller and higher density buildings in the central city [30] as well as the higher land values in Auckland compared to other cities. Nevertheless, the building height data indicates that concrete wall-steel frame hybrid construction has applications across a range of multi-storey building heights.

In examining the lateral load resisting systems, Figure 10c shows that over 40% of the surveyed buildings in Christchurch were designed as dual systems, where both the frames and walls acted together to resist lateral loads in at least one direction. A total of 30% of the buildings had steel frames resisting the lateral load in one direction and concrete walls in the other

direction. A further 20% of the buildings had steel frames designed for gravity loads only and concrete walls resisting all of the lateral loads. In Auckland, 70% of the surveyed buildings used solely concrete walls to resist lateral loads and 20% used a dual system. There were a few buildings in each city where the lateral load resisting system was complex, varying in different areas or different storeys of the building. For example, one building in Christchurch had concrete walls and concentrically braced frames (CBFs) acting orthogonally in the first storey, and eccentrically braced frames (EBFs) and moment-resisting frames (MRFs) acting orthogonally in upper storeys. Such buildings with complex or highly irregular structural designs were lumped together in the “Other” category, comprising 10% of the overall surveyed buildings.

Figure 10g shows that in Christchurch, 54% of the surveyed buildings were designed for limited ductile response ($\mu = 2.0$ to 3.0), while 21% were designed to be nominally ductile. A total of 14% of the buildings had walls designed for nominally ductile response ($\mu = 1.25$) and frames for limited ductile. In Auckland, buildings designed for nominally ductile response comprised at least 68% of the surveyed buildings. Design ductility assumptions could not be found in 11% of the surveyed buildings. Nevertheless, an educated assumption can be made that most of these were designed to be nominally ductile, which would result in roughly 80% of the surveyed Auckland buildings. The prevalence of buildings designed for actions derived from a nominally ductile response is expected in a low-seismicity area such as Auckland [31]. In contrast, higher seismicity in Christchurch prompted buildings to be designed for a more ductile response. Nevertheless, it was noted that concrete wall reinforcement in at least 42% of buildings in both cities were detailed for higher ductility (up to $\mu = 6.0$).

Figure 10d shows that a variety of steel frame systems were implemented in the surveyed buildings. A quarter of the Christchurch buildings had steel frames that were designed to resist gravity loads only (i.e. RC walls resist all lateral loads). This corresponds to six instances of steel gravity frames and one instance of steel gravity beams. Meanwhile, the remaining three quarters were designed for lateral loads. EBFs, MRFs, and CBFs correspond to 25%, 18%, and 14%, of all the surveyed Christchurch buildings respectively. One of the buildings that used CBFs was configured as part of a rocking frame system. Despite the popularity of buckling-restrained brace (BRB) frames in the Christchurch rebuild [1], only two instances were observed in this survey of BRB frames used in conjunction with concrete walls. In one building, the BRB frames were designed to resist 100% of the base shear, and concrete walls with a pinned based detail were used to protect against storey-sway mechanism. In the other case, BRB frames were used with post-tensioned rocking walls that act in orthogonal directions. Three instances of buildings with portal frames were also observed in Christchurch. The steel frames in Auckland buildings were more commonly gravity load resisting only. In particular, steel gravity beams used together with load-bearing concrete walls (e.g. shown in Figure 11) comprised around 40% of the surveyed buildings in Auckland. This appears to be a trend among apartment buildings, as concrete provides effective acoustic and fire protection between apartment units. A further 30% of Auckland buildings used gravity frames, and 30% used braced frames (i.e. CBFs and EBFs).

In both cities, precast concrete wall panels were most common as the construction method. As shown in Figure 10h, 78% of the total surveyed buildings had precast concrete walls only and 14% had a combination of precast and in-situ walls. For example, one building had thick in-situ walls in lower storeys



Figure 11: An apartment building in Auckland made of precast walls connected with steel beams.

and thinner precast walls in upper storeys. Only 8% of buildings used in-situ walls exclusively. One of the Christchurch engineers remarked that while they typically use precast walls, the decision to use in-situ walls for one of their buildings was influenced by the contractor who had invested in in-situ wall formworks prior.

For precast walls, grouted panel-to-foundation and panel-to-panel connections were used for most cases. Only one building had an in-situ stitch at the wall base connection. On the other hand, 20% of surveyed buildings had in-situ stitches for vertical panel-to-panel connections, all of which were located in Auckland. At least one Christchurch building used embedded plates for vertical panel-to-panel connections.

Wall configurations were a mix of core walls, rectangular walls, perimeter walls, and combinations thereof. However, the presence of perimeter walls in almost 80% of the total surveyed buildings, as shown in Figure 10i, demonstrates that the built-in fire rating of concrete walls is a key advantage and may influence the preferred structural layout. Furthermore, only 18% of the surveyed buildings were found to use solely core walls, suggesting that existing literature on concrete wall-steel frame buildings that focused primarily on tall core wall structures with perimeter steel frames may not be relevant in a New Zealand context. In Auckland, another trend can be observed as almost 60% of buildings used a combination of core, perimeter, and interior walls. This can be attributed to the prevalence of apartment buildings in the city and the effectiveness of concrete walls in separating apartment units. Again, this trend highlights the functionality of concrete walls as a critical driver in the selection and layout of the structural system.

Almost all surveyed buildings used cantilevered RC walls. Exceptions include two buildings with coupled RC walls using steel coupling beams, two buildings with post-tensioned rocking walls, and one building with pinned-base RC walls used to protect against soft storey failure.

Precast concrete rib & timber was the most common suspended floor system, accounting for 40% of the total surveyed buildings, closely followed by composite steel tray (32%), as shown in Figure 10e. Rib & timber and composite steel tray were almost equally dominant among Christchurch buildings, comprising 48% and 44% respectively. The popularity of these two suspended floor systems may be attributed to their lightweight nature and compatibility with steel frames. In Auckland, on the other hand, a wider variety of suspended floor systems were found. One-third of the buildings used Flat slab / Unispan floors, and roughly another one-third used rib & timber. The remainder of the Auckland buildings used composite steel trays (20%), precast double tees (15%), and one instance of precast hollowcore floor units.

TYOLOGIES FOR CONCRETE WALL-STEEL FRAME HYBRID BUILDINGS

The lateral load resisting system in each direction was the main parameter used to develop specific typologies for concrete wall-steel frame buildings. Buildings were classified as to whether the lateral loads were resisted by (1) concrete walls only, (2) concrete walls and steel frames acting as dual systems, (3) concrete walls and steel frames in orthogonal directions, or (4)

other irregular systems. For buildings that solely utilise concrete walls as the lateral load resisting system, it was necessary to distinguish those with steel frames and those with steel beams only (i.e. concrete walls resisting all vertical loads). Five different building typologies are proposed and outlined in Table 1, along with corresponding typical wall configurations and steel framing systems. Example model sketches of buildings for each type are shown in Figure 12.

Table 1: Proposed typology for concrete wall-steel frame hybrid buildings.

Label	Typology	Description	Typical wall configuration	Steel framing system
A	Concrete core walls with steel gravity frames	Concrete walls solely resist lateral loads. The steel frames are designed for gravity only.	Core	Gravity frame
B	Concrete walls and steel frames acting as a dual system	A dual concrete wall-steel frame system resists lateral loads in one or both directions.	Core; Combination of core and perimeter	MRF, or braced frame
C	Concrete walls and steel frames in orthogonal directions	Concrete walls resist the lateral load resisting system in one direction and steel frames in the other direction.	Perimeter	MRF, braced frame, or portal frame
D	Concrete walls with steel beams	Concrete walls resist both lateral and gravity loads. Steel beams are used to connect the walls. There may be a few RC or composite beams or columns.	Combination of core, perimeter and interior	Gravity beams only
E	Other	Buildings with complex or irregular designs that do not fit into any other categories. May include buildings that use steel frames and concrete walls in certain storeys/areas but different lateral force resisting systems in others.	Any	Any

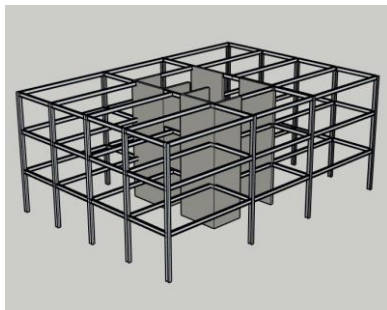

(a) Type A - Concrete core walls with steel gravity frames



(b) Type B - Concrete walls and steel frames acting as a dual system

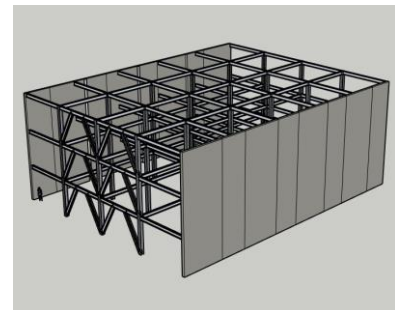

(c) Type C - Concrete walls and steel frames in orthogonal directions

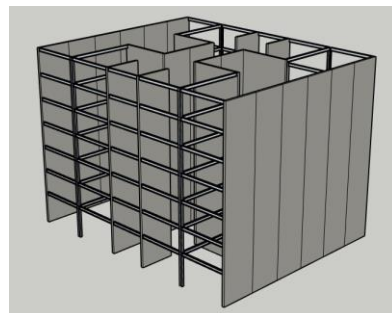

(d) Type D - Concrete walls with steel beams

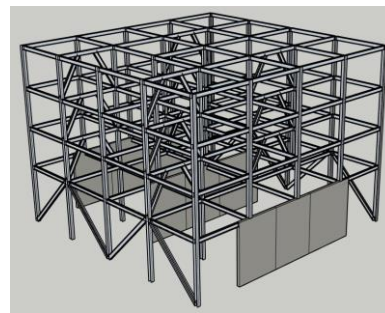

(e) Type E - Other

Figure 12: Example model sketches of building types A, B, C, D, and E.

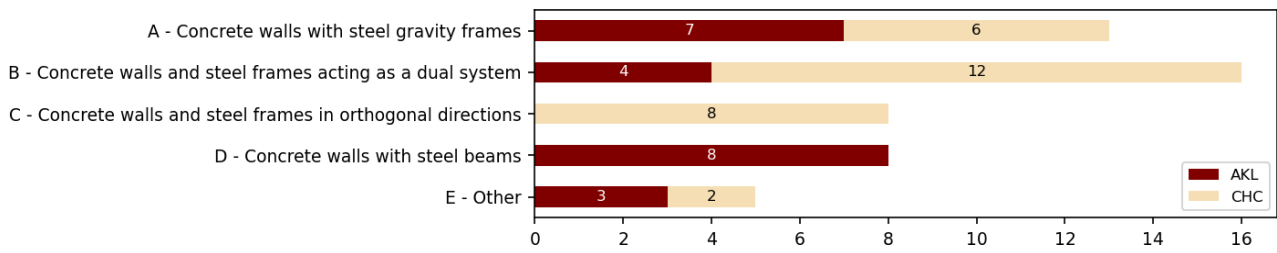
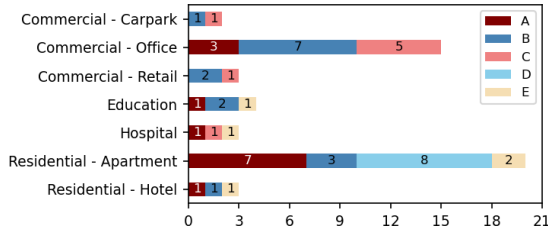
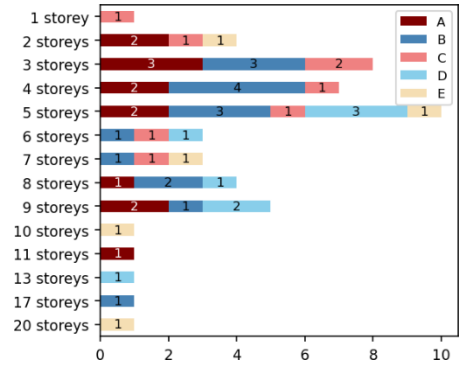

Figure 13: Number of surveyed buildings for each building type aggregated by city.



(a) Building use aggregated by typology



(d) Number of storeys aggregated by typology

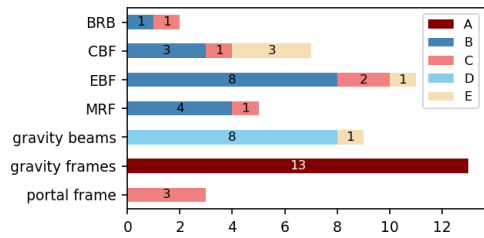

(b) Types of steel framing system aggregated by typology

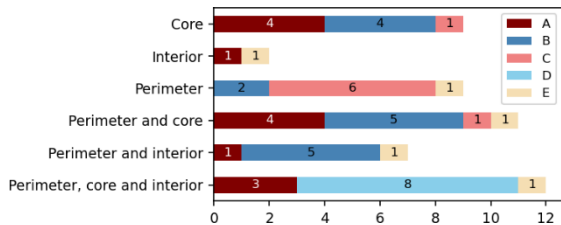

(c) Wall configuration aggregated by typology

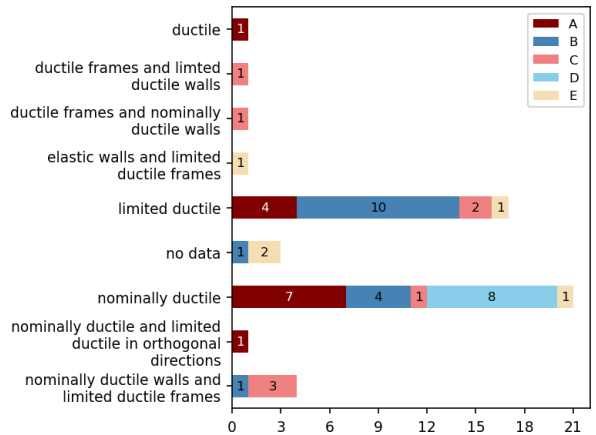

(e) Ductility aggregated by typology

Figure 14: Summary of building structural features aggregated by typology.

To illustrate trends among concrete wall-steel frame buildings, structural features from the surveyed buildings were mapped against the proposed typologies. Figure 13 shows that Type A buildings were equally located in both Auckland and Christchurch. Two-thirds of Type B buildings were located in Christchurch, and one-third were in Auckland. Type C was only located in Christchurch, and Type D was only located in Auckland. Rather than location, this trend can be attributed to the dominant building use and the seismic hazard levels in each city. As shown in Figure 14a, commercial buildings commonly found in Christchurch were usually Type B or C and residential buildings commonly found in Auckland were usually Type A or D.

Figure 14d shows that building typology was generally not influenced by building height. Dual systems were not necessarily found in taller buildings, and different types were observed in various building heights. Instead, building use and level of seismic hazard dictated the building typology. Design ductility also does not appear to influence building typology as Figure 14e shows that Type A buildings in Christchurch and

Auckland were an equal mix of nominally ductile and limited ductile. Type B buildings, all located in Christchurch, were predominantly designed as limited ductile. Type C, also located in Christchurch, were either designed as limited ductile or had nominally ductile walls and limited ductile frames. Type D buildings, all found in Auckland, were designed as nominally ductile.

Typical steel framing systems and wall configurations can be observed among building types, as shown in Figure 14b. Type B buildings utilised EBFs, CBFs and MRFs. Type C also had a variety of steel framing systems, including portal frames. Figure 14c confirmed that Type A buildings typically had core walls, similar to core wall-outer gravity frame buildings found in past literature. However, perimeter walls were also used in instances where there are neighbouring properties. Type B had core and perimeter walls, while Type C usually had perimeter walls. Finally, Type D had combined perimeter, core and interior walls. The trend in Type D buildings is expected as the concrete walls are more abundant, providing separation between tenancies as well as load bearing capacity.

Key Factors Influencing Design

Overall, there is a preference toward structural steel for Christchurch buildings because speed of construction and its lightweight nature makes it suitable for local site conditions. However, the presence of adjacent properties prompts the use of concrete walls around the property boundaries for low maintenance and fire rating. In cases where there are neighbouring properties along both sides of the building, concrete walls tend to be used in one direction and steel frames in the other resulting in Type C buildings (e.g. Figure 14c).

Where there are neighbouring properties on three sides, concrete walls are used along three sides of the building (i.e. two sides and the back), and steel frames are used on the side that faces the street, resulting in a dual system in the direction parallel to the street.

One engineer stated a preference to make the most out of concrete walls required around lifts and property boundaries by using them as the primary lateral load resisting system. Steel frames are added when additional lateral load capacity is needed, resulting in a dual system. This usually happens in taller buildings where concrete walls may not be enough to control drift in the upper storeys or in irregular buildings where torsional demands are an issue. The layout and design of lateral load resisting systems buildings with dual systems (type B) can create additional complexity when considering the torsional response. Such irregularities need to be carefully considered in design with the respective systems sized to minimise torsional demands.

In Auckland, the prevalence of apartment buildings that require separation between tenancies results in the frequent use of concrete walls. Low seismic demands and taller construction in Auckland also result in wind load becoming the primary design driver. As such, concrete walls are the prevalent choice of lateral load resisting system, and there is little need for dual systems except in very tall buildings or highly irregular buildings. Nevertheless, steel beams or steel frames are used together with concrete walls because they require smaller sections compared to concrete frames, resulting in larger floor areas and lower storey heights. One engineer also noted that architects find it undesirable for apartment buildings to have columns protruding from the walls and so concrete walls with steel beams (i.e., Type D) are a practical structural solution. However, this is not an issue with commercial buildings where open spaces are favoured.

One engineer commented that while many engineers liked to use EBFs, the need for open spaces without obtrusive diagonal bracings in commercial buildings drove the use of MRFs. Three instances of portal frames were also observed in Christchurch, built with concrete walls running along the side perimeters, resulting in a structural system similar to that commonly used in industrial warehouse buildings but with multiple storeys, as shown in Figure 15.

According to Christchurch engineers, designing for lower ductility values was prompted by lessons learned from the Canterbury earthquakes to reduce drift and prevent significant inelastic demands at the design level earthquake intensity. The slightly lower design ductility values of concrete walls were also governed by diaphragm capacity and deformation compatibility. For example, in a dual system, an assumed maximum ductility of 2.0 to 3.0 for steel frames would result in an expected ductility value of around 1.25 to 2.0 for concrete walls. One engineer further remarked that these values are a good compromise between ductility and reparability. However, the concrete wall reinforcing was still designed to meet ductile detailing requirements in at least 10% of the surveyed buildings.

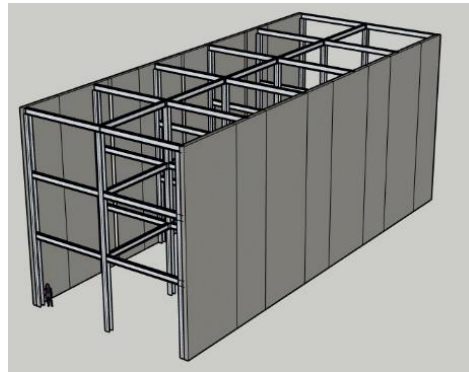

Figure 15: Model sketch of a multi-storey warehouse-like structure with portal frames and concrete walls along the sides.

Regional Trends

Distinct trends were observed among the surveyed Auckland and Christchurch buildings. Auckland buildings tended to be residential apartments five storeys and above. Precast concrete walls that resisted lateral and gravity loads were connected with steel gravity beams. These Auckland buildings were usually designed for a nominally ductile response.

On the other hand, Christchurch buildings were usually office or retail buildings three to five storeys high, with rib & timber or composite steel tray floors. Higher seismic demand resulted in a wider variety of structural systems than in Auckland. A total of 40% of surveyed buildings had dual systems comprising precast concrete walls with EBFs, MRFs or CBFs, and were usually designed for a limited ductile response. Almost 30% of the buildings used steel frames and precast concrete walls as lateral load resisting systems in orthogonal directions. In such cases, the buildings were either designed for a limited ductile response, or the steel frames were designed as limited ductile and the walls as nominally ductile. This included three warehouse-like structures that had portal frames or MRFs with concrete walls running along the sides. A total of 20% of the surveyed buildings used steel gravity frames with core walls.

CONNECTION DETAILS

Beam-to-Wall Connections

For steel beam to concrete wall connections, bolted web plate connections were found in at least 60% of the surveyed buildings. This type of connection is composed of a web plate (also known as 'shear tab' or 'cleat') welded to an endplate that is anchored into the wall and bolted to a steel beam, as shown in Figure 16. These bolted web plate connections were used to connect beams of various sizes (from 310UB to 800WB) to concrete walls. When designing these connections, some engineers considered shear only (i.e. zero moment) while others took into account a small moment produced by bolt eccentricity. With the prevalence of this form of connection and lack of guidelines, it will be necessary to study how different design actions (i.e. shear only vs. shear and moment due to eccentricity) affect connection performance and establish design action guidelines.

On the other hand, welded end plate were observed in at least 12% of the buildings, wherein a steel beam is directly welded to an endplate, which is connected to the wall using post-installed anchors, as shown in Figure 17. These welded end plate connections were usually used for roof purlins and smaller gravity beams.

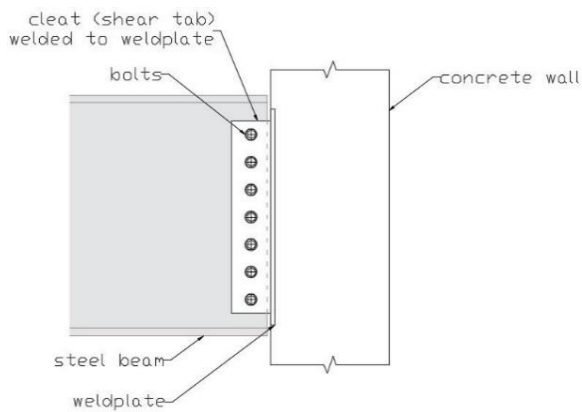

Figure 16: Bolted web plate connection.

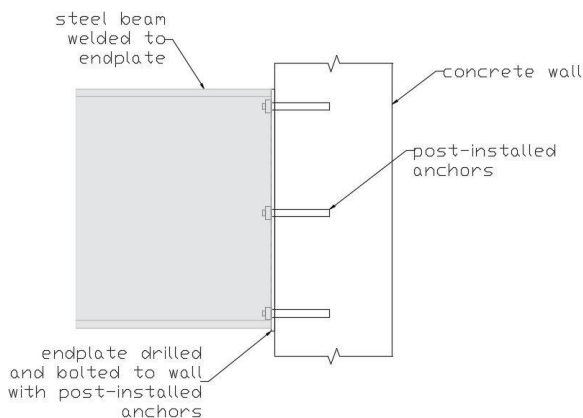

Figure 17: Welded end plate connection.

In bolted connections, the bolt holes were found to be either round or slotted depending on the design engineer. In some buildings, the engineers took into account the slotted holes in design calculations. Whereas others noted that the slots were merely added for improved constructability and calculations were still based on standard circular holes. Although the design of slotted holes is a well-established practice for steel connections [3], no studies have been found on how the use of slotted holes can affect the performance and failure mechanism of concrete wall-to-steel beam connections.

In buildings with welded end plate connections, post-installed anchors were the only form of embedment used to attach the endplate to the wall. Guidelines for post-installed anchors are not present in NZS3101:2006 [2]. However, in buildings where this detailing was implemented, some design engineers were found to have used ACI 318, upon which NZS3101:2006 was based [2,32]. In one instance, the design engineer used manufacturer data.

On the other hand, various kinds of anchors were found among bolted connections. Around 60% of the bolted connections had cast-in endplates embedded onto the concrete wall using headed studs, as shown in Figure 18a. This detailing is prevalent most likely because it is a convenient solution for precast walls and design guidelines are found in Chapter 17 of NZS3101:2006 [2].

Post-installed anchors were found in 15% of the bolted connections, as shown in Figure 18b. These were primarily used in in-situ concrete walls, but were also found in the occasional precast wall. The design practice used for post-installed anchors was found to be the same for both bolted web plate and welded connections.

Other anchors for bolted connections were also found, consisting of reinforcing bars or flat bars in various configurations, such as those shown in Figures 18c, 18d, 18e, 18f. In designing these anchors, the same design procedure for headed studs were adopted by engineers. While it seems logical that reinforcing bars or flat bars can be used as wall anchors and even configured for higher breakout capacity than headed studs, tests should be undertaken to verify their effectiveness and compare the performance of different anchor materials and configurations. Overall, there is a variety of design practices used for steel beam- concrete wall connections in New Zealand, and engineers are found to use different guidelines to design detailing including NZS3101:2006, NZS3404:1997, ACI 318, and manufacturer data. This situation emphasises the necessity to establish design guidelines for concrete wall-steel beam connections.

Floor-to-Wall Connections

In some buildings, the floor systems were seated directly on the walls without the use of secondary steel beams. Examples of floor-wall connections found in the surveyed buildings are shown in Figure 19. Although the figure shows a rib & timber floor, these connections were similarly found in other types of suspended floor systems. Precast floors were typically seated on a steel angle that was attached to the concrete wall with post-installed anchors. It should be noted that such floor to wall seating connections have not been previously tested and therefore their seismic performance is less understood than typical floor seating details for beams.

Floor starters or threaded inserts were used to interface the floor topping to the wall. Similar detailing have been observed in panel-to-foundation connections of low-rise precast concrete wall buildings. A series of tests by Hogan et al. [33] indicated that starter bars exhibit good seismic performance while shallow embedded threaded inserts can result in brittle failure which can be ameliorated by additional reinforcement. As such, tests on floor-to-wall connections should be conducted to check if there will be similar issues.

CONCLUSIONS AND FUTURE WORK

A building survey and typological analysis of 50 concrete wall-steel frame hybrid buildings in Auckland and Christchurch was conducted to investigate recent construction trends. Based on this review the following key findings were drawn:

- New Zealand concrete wall-steel frame buildings are not limited to core wall-outer frame designs found in past literature. These mixed-material structural systems are designed with a variety of wall configurations and steel framing systems and have applications to buildings of different occupancies, heights, and importance levels.
- The functionality and cost-effectiveness of concrete walls, coupled with the reparability, quick construction time, and high strength-to-weight ratio of structural steel, are critical drivers in the decision to combine steel frames and concrete walls.
- Five typologies were developed for recently constructed concrete wall-steel frame hybrid buildings in New Zealand. A total of 30% of the surveyed buildings had concrete wall-steel frame dual systems, most of which were located in Christchurch. A further 25% had concrete walls with steel gravity frames and were equally found in Auckland and Christchurch. A total of 15% of the surveyed buildings had concrete walls in one direction and steel frames in the other, all of which are located in Christchurch. Finally, concrete wall buildings with steel beams comprised 15% of the surveyed buildings, all of which were apartment buildings in Auckland.

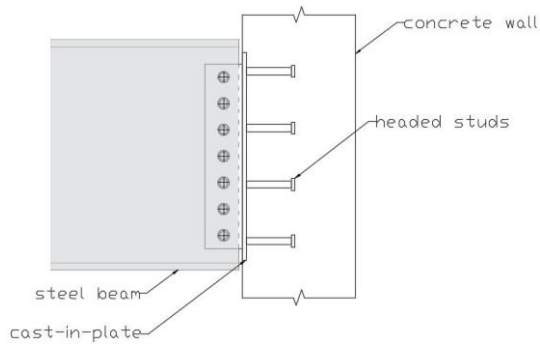

(a) Bolted beam-wall connection anchored to the concrete wall with headed studs.

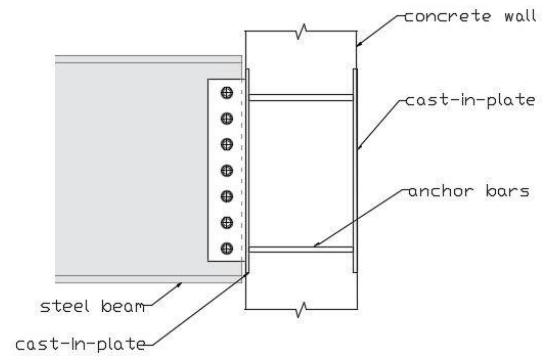

(d) Bolted beam-wall connection anchored to both sides of the concrete wall using round or flat bars.

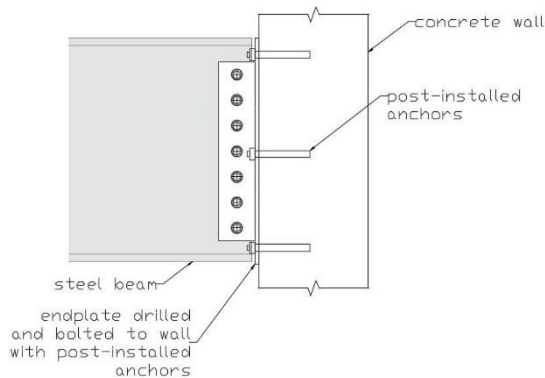

(b) Bolted beam-wall connection with post-installed anchors.

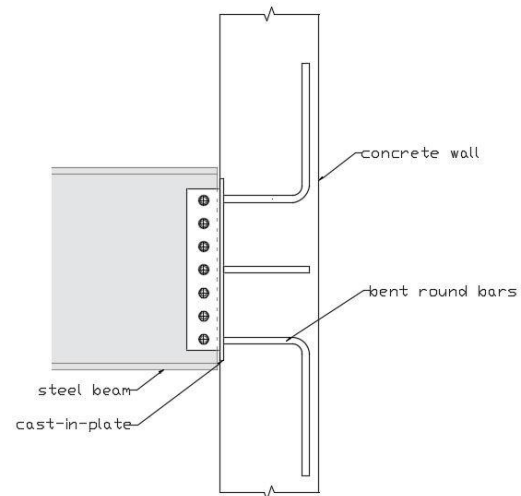

(e) Bolted beam-wall connection anchored to the concrete wall using round bars bent all around.

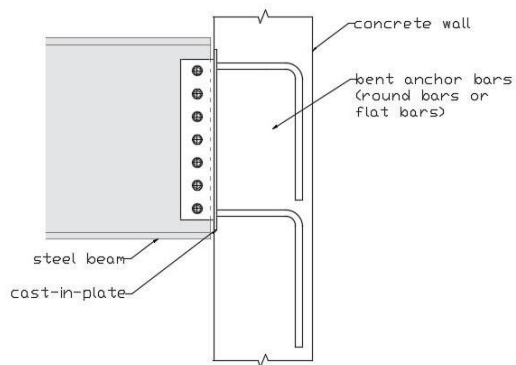

(c) Bolted beam-wall connection anchored to the concrete wall using bent bars.

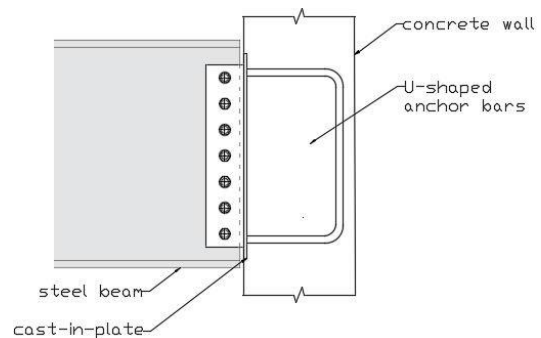

(f) Bolted beam-wall connection anchored to the concrete wall using U-shaped round bars

Figure 18: Different anchor configurations observed in bolted steel beam-concrete wall connections.
(Note: Wall reinforcement has been omitted for clarity)

- Lessons learned after the 2010/2011 Canterbury earthquakes have prompted Christchurch engineers to design buildings with lower ductility and drift demands, regardless of building material and structural system. Nevertheless, concrete wall-steel frame buildings provided a stiff lateral load resisting system to control drifts, and diaphragm compatibility resulted in lower design ductility values.
- Different trends in structural features were observed in Auckland and Christchurch, stemming from regional differences in seismicity and construction demand. Commercial buildings three to seven storeys high with dual frame-wall systems were more common in Christchurch, whereas residential concrete wall structures five storeys and above were prevalent in Auckland.

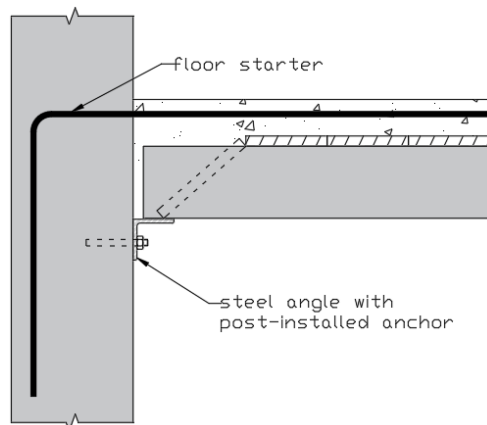

(a) Floor-wall connection with floor starters.

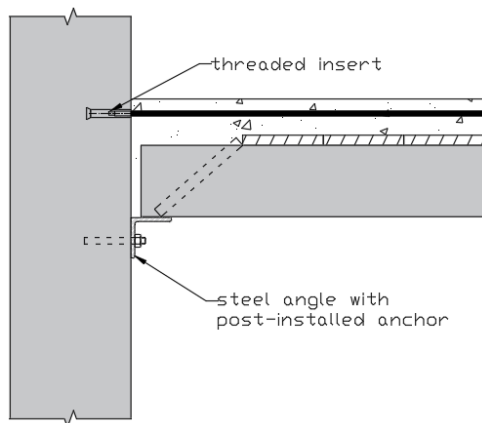

(b) Floor-wall connection with threaded inserts.

Figure 19: Floor-wall connections.

- Bolted connections composed of a web plate and headed stud embedment were found in at least 60% of the buildings in the survey. These connections are commonly assumed as pinned and are designed to carry either shear only or shear and moment due to bolt eccentricity.

The results of this study will be utilised to develop archetype buildings for modelling and testing. Although connections in steel frames are well understood and have detailed design methodologies, connections between steel beams and concrete walls are less understood and do not have established design guidelines. The lack of guidance is evident from the wide range of connection detailing observed in the building survey. Further research on concrete wall-steel frame connections is considered essential to ensure satisfactory seismic performance. Given the concerns on whether current design practices are adequate, an investigation into the rotational capacity and possible failure modes of typical bolted web plate connection detailing found in this study is currently underway. The effects of slotted holes in such connection detailing as well as using a different anchor configuration are also being examined. In addition, the irregular nature of these hybrid dual system buildings means that the compatibility forces in the diaphragms, ductility demands and on each system, and the torsional response may require additional consideration.

ACKNOWLEDGMENTS

The authors would like to acknowledge Auckland Council, Christchurch City Council, Andrew Thompson, Tim Shannon, Jamaledin Borzouie, Cameron MacPherson, Chris Hurst, Andrew Clarke, Hsen-Han Khoo, Karl Dawe, and Andrew Gaul for their assistance and input during the study.

REFERENCES

- 1 Bruneau M and MacRae G (2017). "Reconstructing Christchurch: A Seismic Shift in Building Structural Systems". The Quake Center, University of Canterbury, Canterbury, New Zealand.
- 2 Standards NZ (2006). "NZS3101: Concrete Structures Standard Part 1: The Design of Concrete Structures". Standards New Zealand, Wellington, 309 pp.
- 3 Standards NZ (1997). "NZS3404: Steel Structures Standard Part 1". Standards New Zealand, Wellington.
- 4 Hou G, Chen B, Miao Q, Liu X and Huang J (2006). "Design and research on composite steel and concrete frame-core wall structure". *Jianzhu Jiegou Xuebao, Journal of Building Structures*, **27**(2): 1–9.
- 5 Jiang HJ, Fu B and Liu LE (2012). "Seismic performance evaluation of a steel-concrete hybrid frame-tube high-rise building structure". *Applied Mechanics and Materials*, **137**: 149–153. <https://doi.org/10.4028/www.scientific.net/AMM.137.149>
- 6 Liu A and Zhou D (2005). "Experimental study on seismic behavior of semi-rigid connection between steel beam and concrete wall". *Earthquake Engineering and Engineering Vibration*, **4**(1): 129–137. <https://doi.org/10.1007/s11803-005-0031-x>
- 7 Zhou X and Li G (2010). "Shaking table model test of a steel-concrete composite high-rise building". *Journal of Earthquake Engineering*, **14**(4): 601–625. <https://doi.org/10.1080/13632460903193949>
- 8 Hawkins NM, Mitchell D and Roeder CW (1980). "Moment resisting connections for mixed construction". *Engineering Journal*, **17**(1): 1–10.
- 9 Roeder CW and Hawkins NM (1981). "Connections between steel frames and concrete walls". *Engineering Journal*, **18**(1): 22–29.
- 10 Shahrooz BM, Deason JT and Tunc G (2004). "Outrigger beam-wall connections. I: Component testing and development of design model". *Journal of Structural Engineering*, **130**(2): 253. [https://doi.org/10.1061/\(ASCE\)0733-9445\(2004\)130:2\(253\)](https://doi.org/10.1061/(ASCE)0733-9445(2004)130:2(253))
- 11 Shahrooz BM, Tunc G and Deason JT (2004). "Outrigger beam-wall connections. II: Subassembly testing and further modeling enhancements". *Journal of Structural Engineering*, **130**(2): 262–270. [https://doi.org/10.1061/\(ASCE\)0733-9445\(2004\)130:2\(262\)](https://doi.org/10.1061/(ASCE)0733-9445(2004)130:2(262))
- 12 Garcia R, Sullivan T and Della Corte G (2010). "Development of a displacement-based design method for steel frame-RC wall buildings". *Journal of Earthquake Engineering*, **14**(2): 252–277. <https://doi.org/10.1080/13632460902995138>
- 13 Zhang L and Guo F (2004). "Review of seismic research on steel-concrete mixed structures". *Journal of Earthquake Engineering and Engineering Vibration*, **24**(2): 51–56.
- 14 Crawford SF and Kulak GL (1971). "Eccentrically loaded bolted connections". *Journal of the Structural Division*, **97**(3): 765–783. <https://doi.org/10.1061/JSDEAG.0002844>
- 15 Dai SB, Huang J, Zhang LQ and Zhu J (2007). "Research on mechanical performance of high strength bolt connection joint between steel beam and concrete wall". *Wuhan Ligong Daxue Xuebao, Journal of Wuhan University of Technology*, **29**(11): 103–107.
- 16 GIC (2020). "GIC acquires LG Twin Towers in Beijing". <https://www.gic.com.sg/news-and-resources/gic-acquires-lg-twin-towers-in-beijing/>

- 17 Sritharan S, Beyer K, Henry RS, Chai YH, Kowalsky M and Bull D (2014). "Understanding poor seismic performance of concrete walls and design implications". *Earthquake Spectra*, **30**(1): 307-34.
- 18 Shegay AV, Dashti F, Hogan L, Lu Y, Niroomandi A, Seifi, P, Zhang T, Dhakal RP, Elwood KJ, Henry RS and Pampanin S (2020). "Research programme on seismic performance of reinforced concrete walls: Key recommendations". *Bulletin of the New Zealand Society for Earthquake Engineering*, **53**(2): 54-69. <https://doi.org/10.5459%2FBNZSEE.53.2.54-69>
- 19 Fikri R, Dizhur D and Ingham J (2018). "Typological study and statistical assessment of parameters influencing earthquake vulnerability of commercial RCFMI buildings in New Zealand". *Bulletin of Earthquake Engineering*, **17**(4): 2011–2036. <https://doi.org/10.1007/s10518-018-00523-x>
- 20 Gautam D, Fabbrocino G and de Magistris FS (2018). "Derive empirical fragility functions for Nepali residential buildings". *Engineering Structures*, **171**: 617–628. <https://doi.org/10.1016/j.engstruct.2018.06.018>
- 21 Lang DH, Kumar A, Sulaymanov S and Meslem A (2018). "Building typology classification and earthquake vulnerability scale of Central and South Asian building stock". *Journal of Building Engineering*, **15**: 261–277. <https://doi.org/10.1016/j.jobbe.2017.11.022>
- 22 Russell AP and Ingham JM (2010). "Prevalence of New Zealand's unreinforced masonry buildings". *Bulletin of the New Zealand Society for Earthquake Engineering*, **43**(3): 182–201. <https://doi.org/10.5459/bnzsee.43.3.182-201>
- 23 Tingatinga EAJ, Pacheco BM, Hernandez JYJ, Pascua MCL, Tan LRE, Suiza RM, Mata WL, Longalong REU, Ignacio UJP and Germar FJ (2019). "Development of seismic vulnerability curves of key building types in the Philippines". *New Zealand Society for Earthquake Engineering Annual Conference*.
- 24 Brzev S, Scawthorn C, Charleson AW, Allen L, Greene M, Jaiswal K and Silva V (2013). "GEM Building Taxonomy Version 2.0". Technical Report, GEM Foundation, Pavia, Italy. <https://doi.org/10.13117/gem.exp-mod.tr2013.02>
- 25 Federal Emergency Management Agency (2013). *Hazus®-MH 2.1 Advanced Engineering Building Module (AEBM) Technical and User's Manual*. Department of Homeland Security, Washington, D.C.
- 26 RiskScape (2010). "RiskScape User Manual". <https://wiki.riskscape.org.nz/index.php/Overview>
- 27 Uma SR, Bothara J, Jury R and King A (2008). "Performance assessment of existing buildings in New Zealand". *New Zealand Society for Earthquake Engineering Annual Conference*.
- 28 Statistics New Zealand (2019). "High-density housing on the rise". <https://www.stats.govt.nz/news/high-density-housing-on-the-rise>
- 29 Christchurch City Council (2017). "Christchurch District Plan". <https://districtplan.ccc.govt.nz/pages/plan/book.aspx?exhibit=DistrictPlan>
- 30 Auckland Council (2016). "Auckland Unitary Plan". https://unitaryplan.aucklandcouncil.govt.nz/pages/plan/Book.aspx?exhibit=AucklandUnitaryPlan_Print
- 31 Brooke NJ (2015). "How nominal is a structure's ductility". *The New Zealand Concrete Industry Conference*.
- 32 ACI (2011). "ACI 318-11: Building Code Requirements for Structural Concrete and Commentary". American Concrete Institute, Farmington Hills, Mich., ISBN 9780870317446.
- 33 Hogan L, Henry R and Ingham J (2018). "Performance of panel-to-foundation connections in low-rise precast concrete buildings". *SESOC Journal*, **31**(1): 26–36.