

BEHAVIOUR OF STEEL BEAM-COLUMN CONNECTIONS, MADE USING BOLTED END PLATES.

N.D. Johnstone¹ and W.R. Walpole²

Summary:

Simulated earthquake loading was applied to four cruciform specimens, that represented part of a multistorey frame, including the half-beams and half-columns framing into a typical interior joint. This was made by welding plates on to the ends of the beams and bolting these plates to the column flanges using high strength proof loaded bolts. The joints were designed so that recommendations, previously developed elsewhere for monotonic loading, together with the rules given by New Zealand Standard 3404:1977, could be studied. When the existing rules were followed ductile specimens were obtained; however, when some of the joints were deliberately designed to be understrength, failure modes were obtained that were not predicted by the existing simple design methods.

1. INTRODUCTION:

Bolted end plate steel beam to column connections can facilitate quick structural erection and provide reasonable strength, stiffness and ductile characteristics. In the past there has been a significant amount of research^(1,2,3,4,5), into the behaviour of these connections especially with respect to medium and smaller sized beam members in monotonically loaded situations, for which design recommendations have been developed. This paper describes some recent tests which were carried out to determine the applicability of these recommendations when the connections were subjected to reversing cyclic loads. Plastic analysis was used for assessing the strengths of the connections and their associated beams and columns.

NZS 3404:1977⁽⁶⁾ Clause 12.4.7 requires that the columns be overstrength to discourage the formation of plastic hinges in them, and Clause 12.4.8 requires that the design of connection should allow for moment gradient and strain hardening effects in the beams. A 25% increase in the plastic moment of the beams was allowed above the experimental yield moment when designing the connection of specimens one and two. The connections of specimens three and four were under-designed so that their behaviour could be studied more closely at failure.

It was not intended that this joint should be used as part of a three dimensional frame. The connection tested here can resist significant actions from members in one plane only. Inertia forces normal to this plane must be resisted by a structural system constructed in a normal plane. The form of the experiment was chosen so as to be reasonably representative of a beam-to-column connection in a multi-storey plane under earthquake loading as shown in Figure 1. The beam loads were applied at their ends by means of a hydraulic jack through a tie rod system, and the column axial compression load was applied by two hydraulic jacks

and four macalloy bars. This system did not allow P-delta effects to be generated from relative interstorey lateral displacements as indicated in Figure 1.

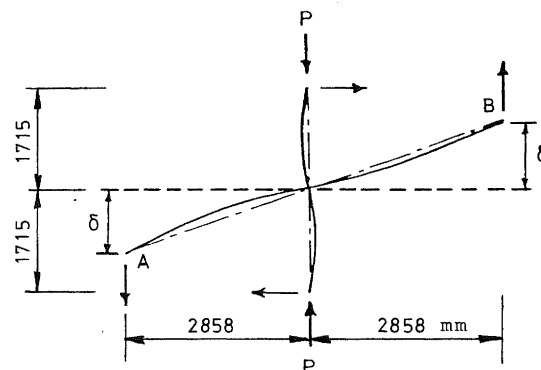

Figure 1 - Arrangement of Test Specimens.

2. DESIGN OF SPECIMENS:

The 310 UB 46 beam size was used for all specimens and has a flange outstand to flange thickness ratio of 6.73 which is reasonably squat compared to the limit, $136/\sqrt{F_y}$ required by NZS 3404:1977 Clause 10.8.1 for a ductile plastic hinge. The column sizes, shown in Table 1, were chosen for specimens one and two so that a moment 25% in excess of the experimental yield moment could be reached in the beam, together with an axial load in the column, which was fixed so that the column was close to forming a plastic hinge. The column size was reduced for specimen three so that a column flange mechanism would develop. This size was maintained for specimen four. The reduced plastic moment allowing for axial load was calculated from NZS 3404:1977⁽⁶⁾ Clause 10.5.2 for preliminary design:

$$M_{pc} = 1.18 \left(1 - \frac{P}{P_y} \right) M_p$$

1. City Engineers Department, Wellington City Council.
2. Department of Civil Engineering, University of Canterbury, Christchurch.

Specimen Number	1	2	3	4
Beam size	310 UB 46	310 UB 46	310 UB 46	310 UB 46
Column size	250 UC 89	250 UC 89	250 UC 73	250 UC 73
End plate thickness mm	32	32	20	16
High strength bolt diameter mm	30	30	24	24
Doubler plates position	Adjacent to column web	On column flange tips	On column flange tips	On column flange tips
Doubler plates thickness mm	2 @ 16	2 @ 16	2 @ 12	2 @ 12
Beam flange weld to end plate	Single bevel butt weld	Pair of 10 mm fillet welds	Single bevel butt weld	Single bevel butt weld
Beam web weld to end plate	Pair of 6 mm fillet welds	Pair of 6 mm fillet welds	Single bevel butt weld	Single bevel butt weld

TABLE 1 - COMPARISON OF SPECIMEN COMPONENT SIZES

For final selection of the axial load, the moment capacity was checked from the more accurate formula given on Page 40 of the AISC Safe Load Tables⁽⁷⁾. The column size chosen must have a flange thick enough to resist the tension bolt forces. Many of the UC sections rolled were found to be adequate for this purpose, but most UB sections were noted to be too thin and would require flange reinforcing plates. The tension force, P_{ms} in the beam flange to form the yield pattern shown in Figure 2 for a column flange with horizontal stiffeners as shown in Figure 3, was calculated for specimen one from the equation recommended by Packer and Morris⁽⁴⁾

$$P_{ms} = F_{yc} T_c^2 \left[\left(\frac{1}{v} + \frac{1}{w} \right) (2m + 2n - D') + \frac{2v + 2w - D'}{m} \right]$$

where $w = (m(m + n - 0.5 D'))^{1/2}$,

F_{yc} = Yield stress of the column flange

T_c = Thickness of the column

& v, m, n, D' are defined in Figure 2.

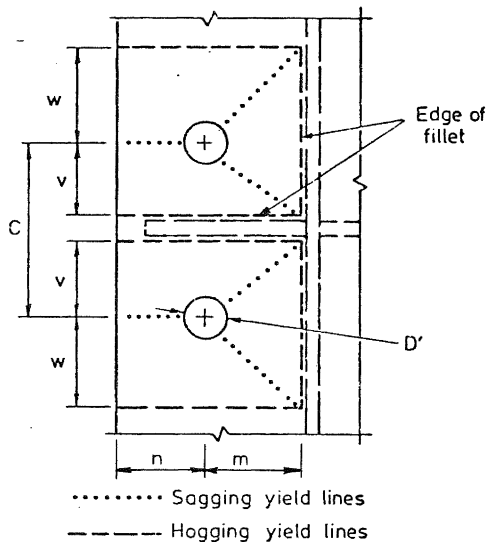

Figure 2 - Yield line pattern for P_{ms} with horizontal stiffeners.

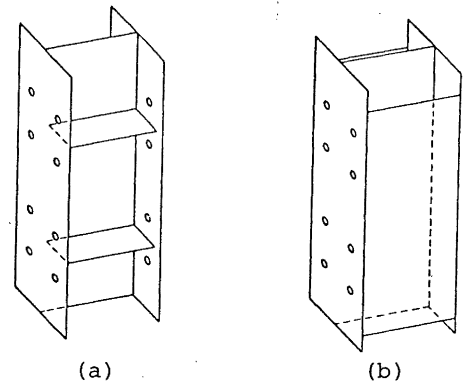

Figure 3

- (a) Horizontal column flange stiffeners, both sides.
- (b) Doubler plates welded to column flange tips both sides.

The tension force, P_{mr} in the beam flange to form the yield pattern shown in Figure 4 was also given by Packer and Morris. The smaller of P_{mr} and P_{ms} was taken to give the capacity of the horizontally stiffened column flange.

$$P_{mr} = F_{yc} T_c^2 \left(\left(\frac{1}{v} + \frac{1}{m} \right) (n - 0.5 D') \right. \\ \left. + \frac{n}{m} + \frac{n}{v} + \pi + \pi \sec^2 \tan^{-1} \left(\frac{2}{\pi} \ln \frac{v}{m} \right) \right)$$

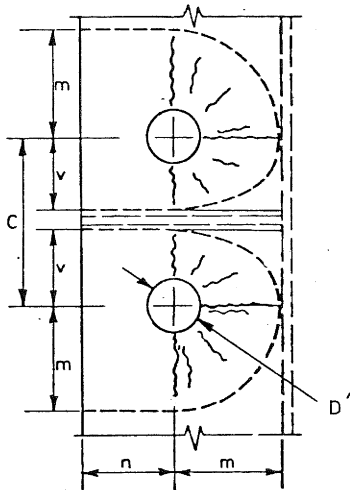

Figure 4 - Yield line pattern for P_{mr} with horizontal stiffeners.

For specimens two, three and four where the doubler plate was butt welded to the column flange tips, and there were no horizontal stiffeners, as shown in Figure 3b, the tension force, P_{mp} in the beam flange was derived⁽⁸⁾ for the yield line pattern shown in Figure 5 and calculated from the following equation:

$$P_{mp} = F_{yc} T_c^2 \left(\frac{2m + 2n - D'}{g} + \frac{2g + c - D'}{m} \right. \\ \left. + \frac{(1 + r)(2g + c) - 2D'}{2n} \right)$$

where $g = \left(\frac{mn(2m + 2n - D')}{2n + (1 + r)m} \right)^{\frac{1}{2}}$

When the vertical distance, c , between adjacent bolts becomes large, then individual mechanisms occur around each of the bolts, as shown in Figure 6 for which the flange force, P_{mq} was derived⁽⁸⁾.

$$P_{mq} = 2 F_{yc} T_c^2 \left(\frac{2m + 2n - D'}{g} \right. \\ \left. + \frac{g(r + 1) - 0.5 D'}{n} + \frac{2g - 0.5 D'}{m} \right)$$

where "g" is the same as for P_{mp} .

The tensile load in each bolt was calculated using the equation recommended by Surtees and Mann⁽⁹⁾

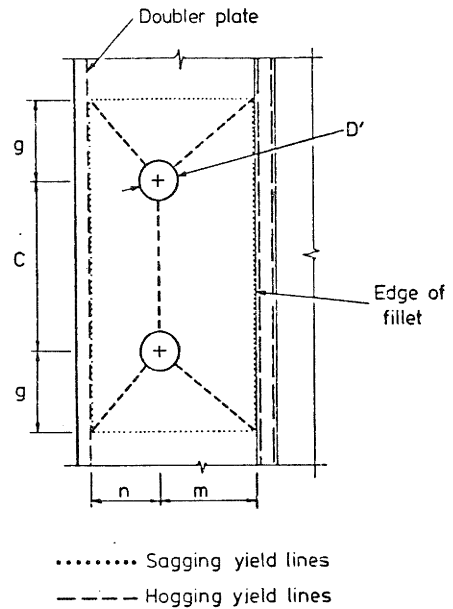

Figure 5 - Yield line pattern for P_{mp}

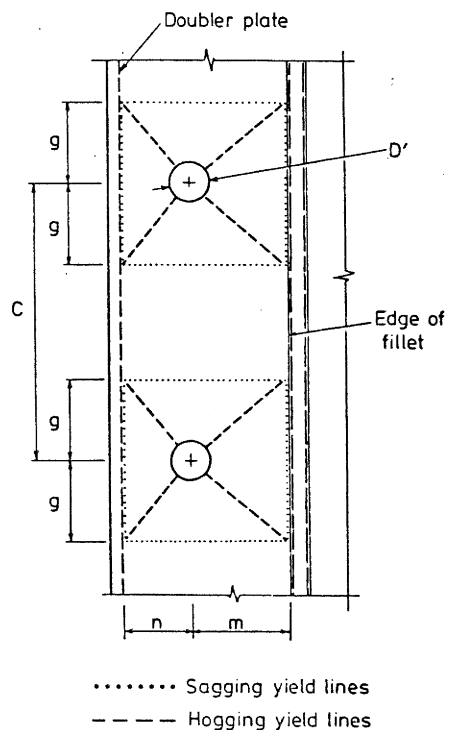

Figure 6 - Yield line pattern for P_{mq}

$$P_f = \frac{M_B}{3 d_f}$$

This assumes that the tension flange loads are distributed equally to the four bolts near the flange, together with an allowance of 33.3% for prying forces. The beam shear was assumed to be carried equally by all eight bolts in the connection. The effect of shear in the bolts was checked using the equation from AS 1511:1973⁽¹⁰⁾

$$\left(\frac{0.6 P_f}{P_{to}}\right)^2 + \left(\frac{0.6 V}{V_{ob}}\right)^2 < 1.0$$

and was found to be minimal. The values of P_{to} and V_{ob} used were taken from the maximum permissible applied loads given in AS 1511, Table 2.

The end plate thickness for specimens one and two was calculated using the equation recommended by Mann and Morris (1)

$$T = \left(\frac{M_B b}{d_f F_{yp} B} \right)^{\frac{1}{2}}$$

This equation may be derived by regarding the beam flange and end plate as a T-stub. The additional strength from the connection of the end plate to the web had been earlier taken into account by Surtees and Mann (9) who suggested the yield line pattern shown in Figure 7, but if the thickness of an end plate is based on their equation below, the end plate will contribute to the flexibility of the structure.

$$T = \left(\frac{M_B}{d_f \left(\frac{2B}{C} + \frac{d_f}{A} \right) F_{yp}} \right)^{\frac{1}{2}}$$

For comparative purposes the loads required to form the yield line pattern of Surtees and Mann (9) were calculated and these were compared to the load to reach the capacity of the other joint components, in Table 2. Specimens three and four had weak end plates.

The panel zone was checked by Clause 12.4.9 of NZS 3404:1977:

$$\left(\frac{P}{A_s F_{yc}} \right)^2 + \left(\frac{V}{0.55 A_w F_{yw}} \right)^2 < 1.0$$

where A_s was taken to be the area of the column the cross-sectional area and A_w to be the cross-sectional area of the column web and doubler plates.

Where no horizontal stiffeners are provided the column web and doubler plates should be checked for crushing under the beam flange forces, by the equation recommended by Hogan and Thomas (11)

$$P_{TB} < F_{yc} t_c (T_B + 5 k_c + 2T).$$

They should also be checked for buckling under these forces, the capacity being determined from the safe load for an unstiffened web from Clause 5.13.2.1 of NZS 3404:1977 divided by 0.6.

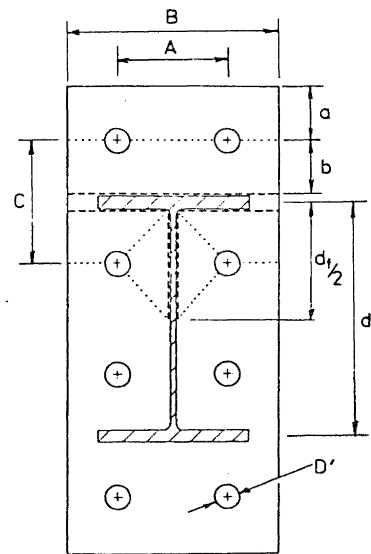

Figure 7 - Yield line pattern for the end plate.

Specimen number	1	2	3	4
Beam hinge	1.00	1.00	1.17	1.67
Column hinge	1.30	1.30	1.21	1.70
End plate mechanism	Mann & Morris (5) 1.38	1.54	0.99 beam A 1.18 beam B	0.94 A - load 0.79 A + load 0.82 B ± loads
Surtees & Mann (9)	2.12	2.12	1.13	1.00
Yielding of panel zone (6)	1.10	1.10	1.00	1.41
Column flange mechanism (8,9)	1.13	1.56	1.08	1.60
(Specified) proof load of bolts with 33% prying	1.37	1.37	1.00	1.43

TABLE 2 - RELATIVE EXPERIMENTAL STRENGTHS OF SPECIMEN COMPONENTS

The deflections of the specimens one and two, under loading sufficient to cause yield moments in the beams, gave a sway angle of 0.0135 which exceeded the ratio of 0.010 recommended in Clause 3.8.3 of NZS 4203:1976⁽¹²⁾ with separated non-structural elements under code loading increased by the modification factor given by Clause 3.8.1. Hence this requirement would govern over strength requirements with this code and as a result ductility demands are likely to be reduced.

The details of the specimens tested are shown in Figures 8, 9 and 10.

3. TEST RESULTS:

The loading sequence followed the method generally used at Canterbury University, whereby the deflections at ductilities ± 0.75 are determined experimentally, by applying forces to cause 75% of the experimental beam yield moment, based on coupon tests for yield stress and a known geometric section shape. The following cycles are deflection controlled, with gradually increasing peak displacement magnitudes, which are multiples of the average deflections in cycle one.

The member displacement ductility factors quoted in this paper follow the definition of Clause C12.2.1 of NZS 3404:1977 i.e. "the ratio of the maximum transverse deflection developed in a member to its yield deflection". The "yield deflection which produces yield point stresses in the extreme fibres, multiplied by the shape factor for the section". These definitions modify those given in NZS 4203:1976⁽¹²⁾, and are intended to cover the situation where a plastic hinge is formed in the beams

adjacent to the column flange face. The above procedure was followed with specimens one and two. For specimens three and four the imposed deflections were essentially similar to those used for specimens one and two, except that higher deflections were achieved, with some extra cycles of loading.

The relationship obtained for specimen one between the load at the right-hand end of the beam and the deflection of that end is shown in Figure 11. The relationship at the left-hand end was practically identical. After ductilities of four had been reached, the beams started to bend and twist, out of the plane of loading, and this was only partially restrained by the bracing. The load carrying capacity continued to rise, with strain hardening until ductility five, after which the load carrying capacity dropped a little, with further lateral and local buckling. The end plate did not deform significantly, although some yielding occurred. Similarly shear deformations in the panel zone were small although strains well in excess of yield were obtained, as would be expected from Table 2 where it is noted that only 10% extra beam load was required to cause yield in the panel zone above that required to form a plastic hinge in the beam, without strain hardening. Elongation and bending of the bolts was minimal.

For specimen two the relationship obtained between the load at the left-hand end of the beam and the deflections at this end is shown in Figure 12. The relationship at the right-hand end was practically identical to the left-hand end and the performance of this specimen without horizontal stiffeners was similar to specimen one.

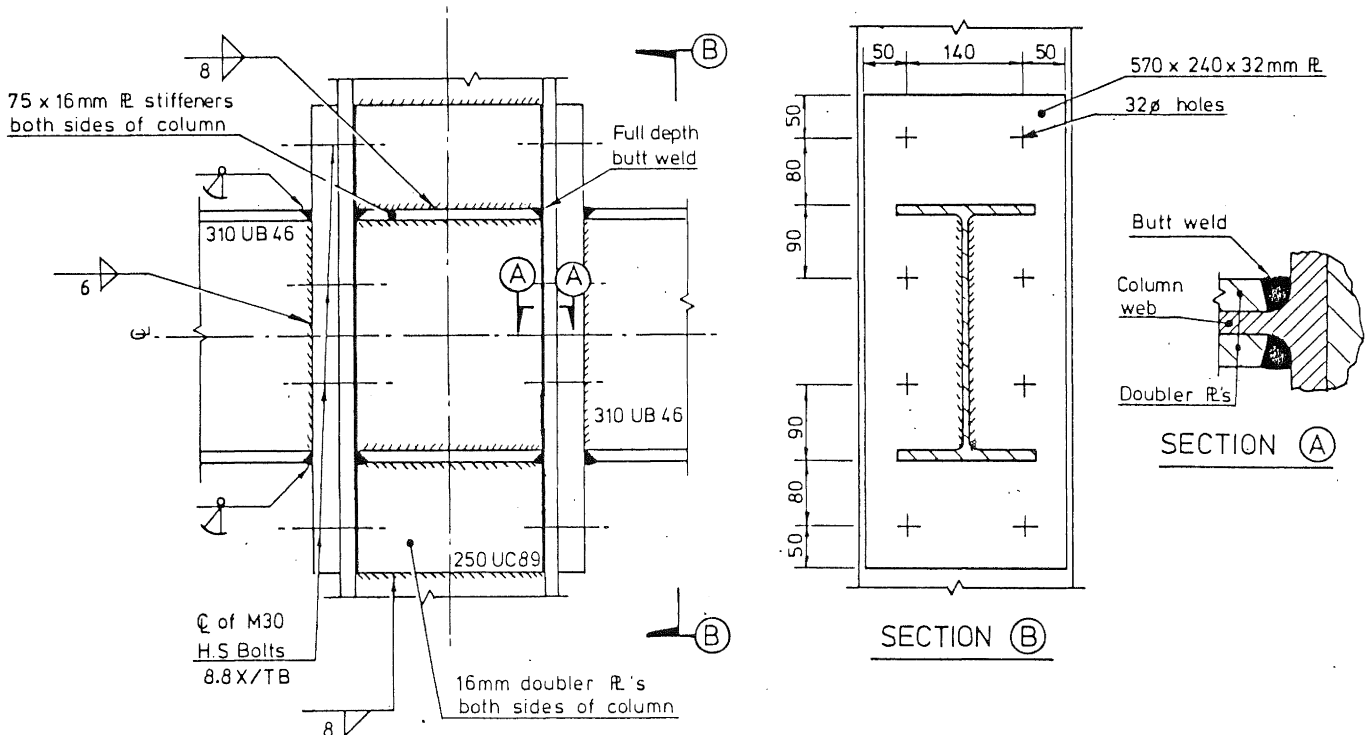

Figure 8 Joint Details for Specimen One

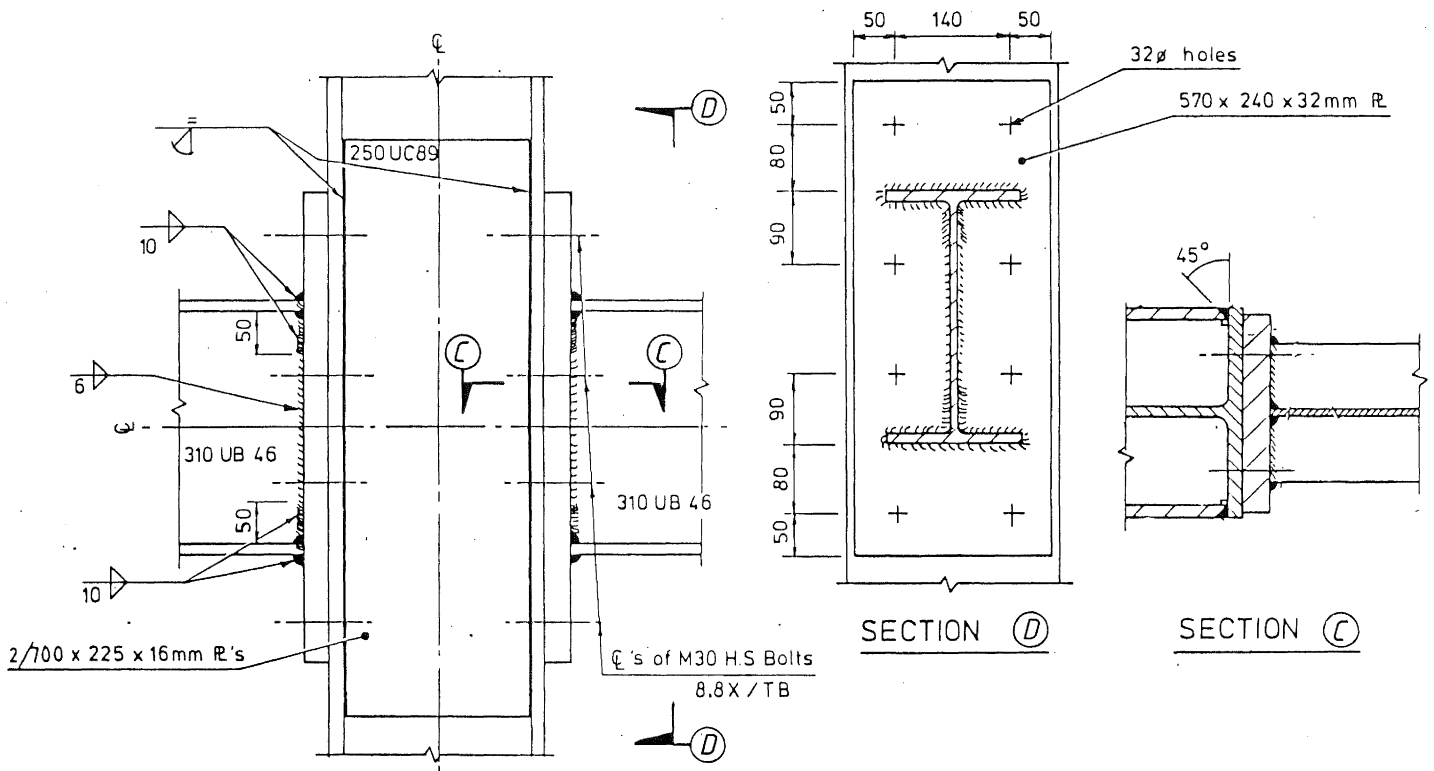

Figure 9 Joint Details for Specimen Two

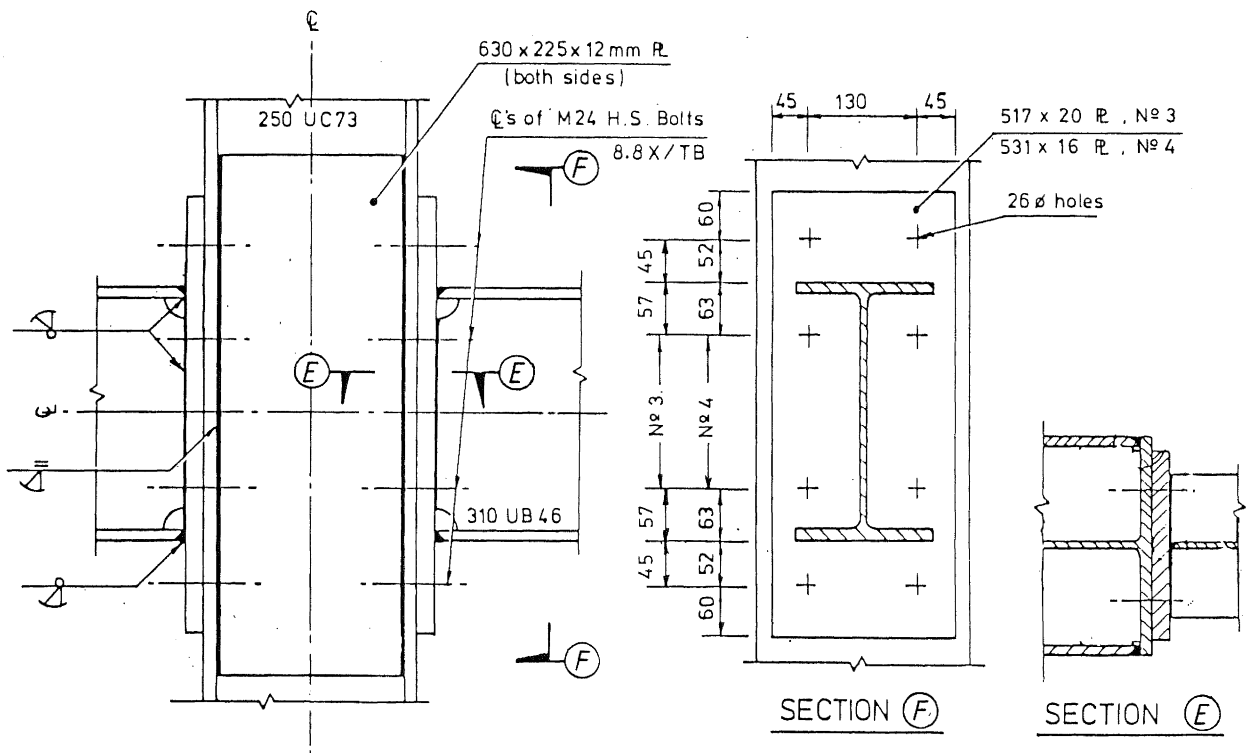

Figure 10 Joint Details for Specimens Three and Four

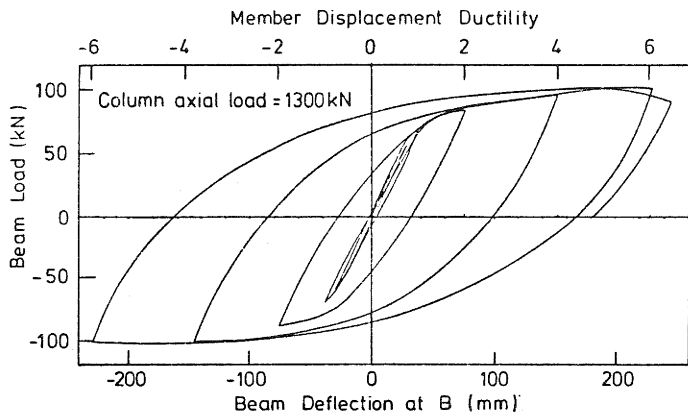
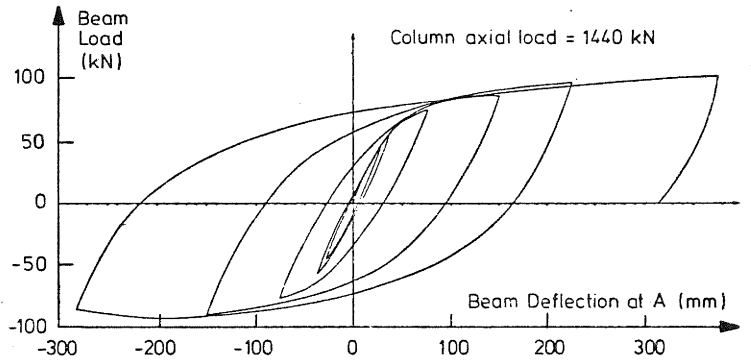
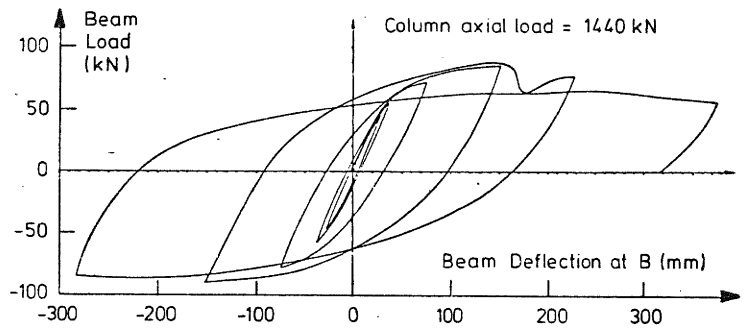

Figure 11 - Load-deflection relationship for Specimen 1.



(a) Left-hand beam



(b) Right-hand beam

Figure 13 - Load-deflection relationship for Specimen 3.

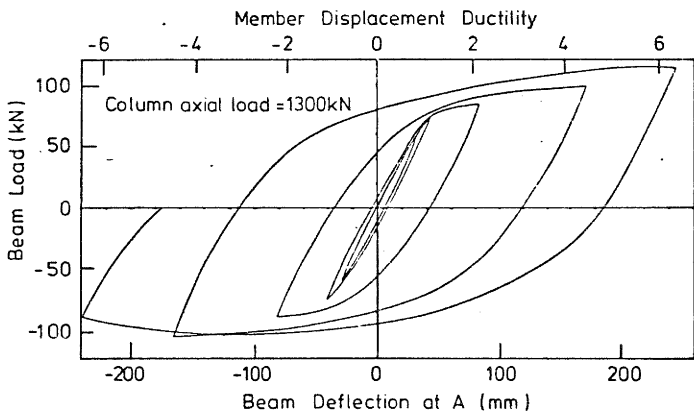
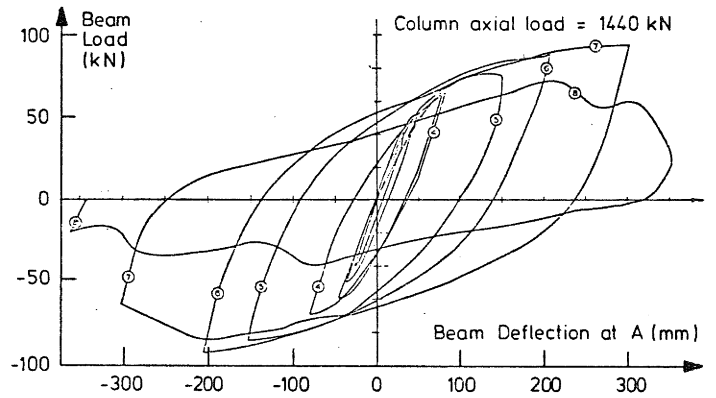

Figure 12 - Load-deflection relationship for Specimen 2.

The plots of load versus deflection for the ends of the left-hand and right-hand beams for specimen three are shown in Figure 13. Out of plane bending and twisting in the beams, together with local buckling was of less importance in specimens three and four, because the spacing of the lateral bracing was reduced to half that used for specimens one and two, and also the stresses in the beams were lower for specimen three and four. At a beam end deflection of 152 mm in the fourth cycle, for the right-hand beam of specimen three, a cleavage fracture started to spread through the end plate just outside the edge of beam flange butt weld. This fracture caused a sudden drop in the load carried as shown in Figure 13b, because only the inner bolts now carried load. It was found that the column flange deformed significantly under the action of the tension bolt loads. This was particularly marked for the two bolts carrying all the flange load after the end plate fracture; and eventually this local overload and deformation caused the doubler plate to column flange tip butt weld to fail. Yielding of the column flanges and webs was occurring just beyond the edge of the doubler plates.

The load-deflection performance for the left-hand and right-hand beams of specimen four are shown in Figure 14. It



(a) Left-hand beam

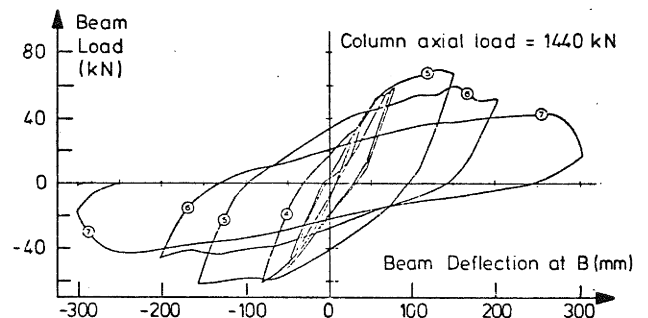

(b) Right-hand beam

Figure 14 - Load-deflection relationship for Specimen 4.

was found that specimen four was initially about 30% more flexible than specimen three. It was also found that there were perceptible differences in stiffness between the two beams of specimen four and also differences for either beam between stiffness in each direction. There were noticeable differences in the dimension b between all four beam flanges. This was compensated to some extent by the differences in $(c - b)$. This problem is unavoidable because of rolling tolerances on the beam depths, unless the end plate hole positions are fixed after measuring the beam depth. Also the weld reinforcement or splay varied significantly between flanges. The left-hand beam was noticeably weaker than the right-hand beam throughout the test, in both the initial elastic region and the plastic region. Lower loads were required to reach the same deflection. The difference in behaviour became particularly pronounced after cycle 5, with the formation of cracks at the edge of the beam flange to end plate butt welds, and the eventual spread of this crack through the end plate.

The deformation of the end plate into double curvature was evident near the end of cycle 4 at beam deflections of - 81 mm. Half-way through cycle 5 at a deflection of 150 mm, all the significant plastic deformation was occurring in the end plate. The waviness in Figure 14 for cycle 6, is caused by loss of strength due to cracking, then strain hardening followed by further crack penetration and more strain hardening. Just before reaching the maximum deflection in cycle 6 the crack near the edge of the butt weld between the beam flange and the end plate penetrated right through the end plate at deflection of - 169 mm. On reloading in the positive direction the right-hand beam exhibited significantly less stiffness in cycle 7 with the crack at the edge of weld between the end plate and the beam flange propagating through the end plate of beam B at a deflection about + 260 mm together with the failure of one of the inside bolts before a deflection of + 302 mm was reached. On completing cycle 7 to deflection - 302 mm, there was significant loss of stiffness and a further inside bolt failure on the right-hand beam. Also during cycle 7 a cleavage crack started to spread through the end plate of the left-hand beam at the edge of the flange butt weld, at a deflection of about - 220 mm. Only the left-hand beam was loaded in cycle 8 and at a deflection of about 220 mm a cleavage crack again started to spread through the end plate and the inside bolts failed. On reloading in the negative direction a cleavage crack spread through the end plate with only the inside bolts carrying significant load until they failed, leaving only a small amount of load to be carried by the outside bolts.

4. DISCUSSION OF RESULTS

In these tests all four specimens were generally well behaved, although the specimens three and four, where the connections were deliberately underdesigned, produced degrading hysteresis loops as higher ductilities were achieved. Hence this type of design would only be acceptable where low ductilities were required.

Specimens one and two produced well-formed ductility loops and it would appear that connections designed in this way, or possibly even less conservatively, would produce the ductilities required by the commentary of NZS 4203:1976. However it is unlikely that structures, which are as flexible as these specimens, would require the ductilities as high as suggested by that commentary. The cycling of specimens one and two was discontinued when the deflection of the specimens reached the limits of the rig at that time. Significant twisting of the beams occurred although the bracing complied with the rules of NZS 3404:1977; however the connection showed no signs of distress even at the high ductilities reached.

The connections in specimens one and two were strong enough to transmit beam actions and to encourage most of the inelastic deformations to occur in the beams. In specimen three the left-hand side of the connection behaved very well with respect to its design strength. The right-hand side was strong enough to surpass its design strength but it did not have the ductile characteristics in the end plate, and possibly in the column flange stiffening, to carry the ultimate load to as high a ductility as the other side. In specimen four where the end plates were the weakest elements of the specimen, it was found again that the end plates did not provide sufficient ductility, and cleavage fractures through the end plates eventually occurred.

In specimens one and two, lateral bracing was provided for the beams at a distance of 2130 mm from the end plate. This length may be compared with the code⁽⁶⁾ requirements (Clause 10.9) of $960 \alpha r_y / \sqrt{F_y}$ which was calculated to be 2370 mm for Y these specimens, with α as one, r_y as 39.0 mm and F_y as 250 MPa. Significant lateral bending and twisting had occurred when the tests one and two were stopped, at a beam end deflection of 238 mm, because of the magnitude of the end deflections, caused by in-plane beam bending. The beams were still able to carry high loads at this stage despite their lateral twist and local buckles. To reduce these out-of-plane deformations, additional braces were placed on the beam at 980 mm from the end plate, for specimens three and four.

When proof loading bolts, with the 32 mm thick end plates in specimens one and two, it was difficult to bring the joint surfaces into contact without a very high bolt load. In these circumstances it is better to use shims to pack the joint. In specimen three the loads in the left-hand beam bolts exceeded their design capacity, based on specified proof stress, without failure by a factor of 1.54. After fracture had occurred in the end plate of the right-hand beam the bolts just inside its tension flange had to carry a very large load. The load on these bolts exceeded their design capacity by a factor of 1.7, ignoring prying. For this type of connection it appeared that the load was shared equally among the four tension flange bolts, because whilst the bolts inside the beam flanges carry more of the tension flange load, the bolts outside it appear to be subjected to

higher prying effects. One feature which was evident in these tests, was the reduction in the prying effects due to the deformation of the column flanges. If these column flange deformations had not occurred then the bolt prying effects would have been larger. The beam shear force in all four specimens was transferred across the interface between the end plate and the column flange predominantly by friction. This was deduced from the fact that there was no significant relative sliding movements.

In specimens one to three the portion of the end plate outside the beam tension flange did not deform in double curvature to the extent that was initially assumed. In specimen three the deformation of the column flange relaxed the constraints that encourage the end plate to stand out to develop a reverse curvature in itself. Subsequently most of the inelastic deformation, that occurred in the end plate, was concentrated in the area immediately adjacent to the beam tension flange. The end plate inside the beam flanges seemed to behave generally in the way that was predicted by Surtees and Mann⁽⁹⁾. This was perhaps most obvious after fracture had occurred in the right-hand beam end plate of specimen three. After this fracture had formed the bolts and end plate immediately inside the beam tension flange were able to support a beam moment of 70% of what it was immediately prior to the fracture event. This decrease in load carrying capacity is shown in Figure 13b and indicates that the larger portion of the beam tension flange force was carried by the end plate immediately inside that flange. Close inspection of that end plate in the region between the beam flanges after testing showed that it had deformed in much the same way as that assumed by Surtees and Mann⁽⁹⁾. In particular the deformation in the end plate due to the restraining effect of the beam web went to zero at the mid depth of the beam. One variable that Surtees and Mann's equation, for end plate thickness does not include is the thickness of the beam flange and web and the thickness reinforcement or splay of the welds, e.g. fillet welds or butt welds. It was apparent throughout the tests that the end plate deformations around the beam tension flange were quite sensitive to the magnitude of "b", see Figure 7.

The fracture in the specimen three right-hand beam end plate occurred in an area of high stress concentration. These stresses were due to bending in the end plate and tension from the beam tension flange. The magnitude of these stresses was thought to have been increased by the close proximity of the bolts to the beam tension flange. Their close proximity may have prevented the stresses from dispersing more evenly across the end plate width. The curvature ductility demand was greater in the end plate immediately outside of the beam tension flange than it was immediately inside it. Similar cleavage fractures occurred in all the end plates of specimen four. There, the end plate was significantly understrength and most of the plastic deformations were concentrated into a short

length of end plate, where sharp curvatures occurred. The simple theory used to analyse the end plate behaviour does not take account of the high stresses which must occur in transferring the beam flange stresses into the bolts.

In these four specimens two different types of column flange stiffening were used. The first and more conventional type used in specimen one resulted in some significant welding distortions although it would probably have still been acceptable in practice. The second type of stiffening tested here in specimens two to four was more easily fabricated and resulted in only relatively small welding distortions. The column flanges of specimens one and two both had adequate strength and deformed very little. In specimens three and four significant plastic deformations occurred in the column flange under tension bolt loads.

5. CONCLUSIONS

- 5.1 Four bolted end plate beam to column connections were tested here. The first two were designed to comply with the NZS 3404:1977. This was done by using the equations set out in Section 2 of this paper and assuming beam strain hardening of 25% above the actual yield stress. The third and fourth connections were underdesigned so that their behaviour at high ductilities could be more closely studied.
- 5.2 In the first two tests the connections were able to support the ultimate plastic hinge beam loads in a relatively stiff manner with significant ductilities and strain hardening.
- 5.3 In the third and fourth tests the connections underwent larger ductile deformations at relatively higher loads without any strength degradation until later in the tests when failures occurred in the end plates and bolts. Although each of these individual components provided only limited ductility, the overall beam behaviour was still ductile, but some degradation occurred.
- 5.4 The tests indicated that the beams needed laterally restraining at closer intervals than those required by the Standard AS 1250:1975 if higher ductilities were to be achieved in the beams.
- 5.5 The tests carried out here have not been able to cover a wide range but their results indicate that these connections can be designed and fabricated to reliably withstand reversed cyclic loads from yielding beams.
- 5.6 Further research is required to establish a theory which predicts the formation and spread of cleavage fractures through the end plates.

- 5.7 Further research is required into other configurations of end plated connections, such as these utilizing eight bolts per flange, haunched beams, and other forms of column flange stiffening.
- 5.8 This type of connection could be used for other member sizes; but with heavier sections more bolts will be required to be accommodated in a limited space or else large bolts will be required. Difficulties can arise in proof loading M 30 or larger bolts without special equipment.
- 5.9 It is hoped that standardised connections can be developed, because they would avoid the trial and error process of design.

6. ACKNOWLEDGEMENTS

The first three specimens were tested by the first author during project work for his Master of Engineering studies⁽¹³⁾ under the supervision of the second author, who tested specimen four.

The financial support and interest of the New Zealand Heavy Engineering Research Association (Inc) is gratefully acknowledged.

Thanks are due to the University of Canterbury for the provision of laboratory technicians, equipment and space.

Ajax GKN Ltd kindly supplied all bolts for specimens and rig construction.

Professors R. Park, T. Paulay and I.R. Wood are thanked for their interest and encouragement.

7. REFERENCES

1. Sherbourne, A.N., "Bolted Beam to Column Connections", The Structural Engineer, Vol. 39, June 1961, pp. 203-210.
2. "Plastic Design in Steel - A Guide and Commentary", ASCE Manual No. 41, American Society of Civil Engineers, New York, 1971.
3. Fisher, J.W. and Struik, J.H.A., "Guide to Design Criteria for Bolted and Riveted Joints", John Wiley and Sons, New York, 1974.
4. Packer, J.A. and Morris, L.J., "A Limit State Design Method for the Tension Region of Bolted Beam/Column Connections", The Structural Engineer, No. 10, Vol. 55, Oct. 1977, pp. 446-458.
5. Mann, A.P. and Morris, L.J., "Limit Design of Extended End-Plate Connections", Journal of Structural Division, American Society of Civil Engineers, ST3, March 1979, pp. 511-526.
6. NZS 3404, "Code for Design of Steel Structures", Standards Association of New Zealand, Wellington, 1977.

7. "Safe Load Tables for Structural Steel", Third Edition, Australian Institute of Steel Construction, Sydney, 1975.
8. Johnstone, N.D. and Walpole, W.R., "Bolted End Plate Beam to Column Connections Under Earthquake Type Loading", Research Report 81-7, Department of Civil Engineering, University of Canterbury, Sept. 1981.
9. Surtees, J.O. and Mann, A.P., "End-Plate Connections in Plastically Designed Structures", Proceedings of Conference on Joints in Structures, Vol. 1, Paper 5, University of Sheffield, England, July 1970.
10. AS 1511, "SAA High Strength Structural Bolting Code", Standards Association of Australia, Sydney, 1973.
11. Hogan, T.J., and Thomas, I.R., "Standardised Structural Connections, Part B: Design Models", Australian Institute of Steel Construction, Sydney, 1978.
12. NZS 4203, "Code of Practice for General Structural Design and Design Loadings for Buildings", Standards Association of New Zealand, Wellington, 1976.
13. Johnstone, N.D., "Bolted End Plate Beam to Column connections Under Earthquake Type Loading", Unpublished M.E. Thesis, University of Canterbury, Feb. 1981.

8. NOTATION

- | | |
|----------|-----------------------------------------------------------------------------|
| A | = Horizontal distance between bolt holes (gauge) |
| A_s | = Area of column section |
| A_w | = Cross-sectional area of column web and doubler plates |
| B | = Width of end plate |
| b | = Distance from centre of outer bolt hole to edge of beam flange weld |
| C | = Vertical distance between bolt holes (pitch) |
| D' | = Bolt hole diameter |
| d_f | = Distance between the centres of the beam flanges |
| F_y | = Yield stress of the beam |
| F_{yc} | = Yield stress of the column |
| F_{yd} | = Yield stress of the doubler plate |
| F_{yp} | = Yield stress of the end plate |
| F_{yw} | = Weighted average of the yield stress of the column web and doubler plates |

- g = Distance from bolt centre line to sagging yield line for minimum collapse load
- k_c = Thickness of the column flange plus web root fillet
- M_B = Overstrength yield moment of the beam i.e. probable yield moment increased by strain hardening
- M_p = Plastic moment capacity of the column
- M_{pc} = Plastic moment capacity of the column, allowing for axial load
- m = Distance from the bolt hole centre to the edge of the root fillet
- n = Distance from the bolt hole centre to the edge of the doubler plate
- P = Axial load in the column
- P_f = Tensile load in the bolt
- $P_{ms}, P_{mr}, P_{mp}, P_{mq}$ = Tension force in the beam flange to cause the yield line patterns of Figures 2, 4, 5 and 6 respectively
- P_{TB} = Compression flange force in the beam
- P_{to} = Maximum permissible tensile force in the bolt from Table 2 AS 1511 - 1973
- P_y = Squash load of column i.e. area of column multiplied by the column yield stress
- r = Ratio of the moment capacity of doubler plate to the column flange i.e. $F_{yd} T_d^2 / F_{yc} T_c^2$
- r_y = Radius of gyration of the beam about its minor axis
- T = Thickness of the end plate
- T_B = Thickness of the beam flange
- T_c = Thickness of the column flange
- T_d = Thickness of the doubler plate
- t_c = Thickness of the column web
- V = Shear force carried by the bolt or by the panel zone from the resultant of beam flange forces and the column shear force
- V_{ob} = Maximum permissible shear force on the bolt from Table 2 AS 1511 - 1973
- v = Distance from the centre of the bolt hole to the edge of the weld to the horizontal stiffener
- w = Distance from the centre of the bolt hole to the yield line for the minimum value of the collapse load