

## THE SHEAR STRENGTH OF SHEAR WALLS

T. Paulay \*

**ABSTRACT** : To enable a comparison between the shear strength of shear walls and that of reinforced concrete beams to be made, the behaviour of the latter is briefly reviewed.

The findings of research projects, related to deep beams and the effects of repeated cyclic loading, are summarised. More detailed information on the shear strength of deep beams, tested at the University of Canterbury, is presented. Particular problems associated with four classes of typical shear walls of multi-storey structures are briefly highlighted. The current recommendation of the SEAOC code, as applied to shear walls, are critically examined and certain anomalies, which may ensue from their interpretation, are illustrated. Areas of research, related to the full evaluation of reinforced concrete shear wall behaviour, are suggested. The paper concludes with a number of design recommendations which suggest themselves from this review.

### 1. INTRODUCTION

The use of shear walls, as major lateral load resisting components in multistorey structures is standard design procedure. The assessment of their required strength, likely behaviour and aspects of detailing are largely based on "good engineering practice". This draws from the analogy to other similar structures, such as reinforced concrete beams, and from the observed behaviour of structures which were exposed to seismic shocks.

It is only recently that attempts were made to codify certain aspects of shear wall design. These recommendations were based on a limited amount of experimental evidence and presumably on some theoretical considerations. Some features of existing code rules will be discussed later. Because of the lack of factual information on many features of shear wall behaviour, understandably, code writers approach the problems with considerable caution or they do not mention them.

A brief review of our present understanding of the shear resistance of reinforced concrete beams is presented to assist in the evaluation of the likely behaviour of shear walls. Certain features, such as the effect of cyclic loading, deep beam behaviour are discussed in greater detail. Much of this information was obtained from a continuing research project on shear walls at the University of Canterbury. It is attempted to interpret some of these findings in terms of likely shear wall behaviour. After a brief examination of code requirements a number of design recommendations are made.

The emphasis is placed on various aspects of shear strength. The discussion of other equally important features of shear wall design is omitted.

### 2. THE SHEAR RESISTANCE OF REINFORCED CONCRETE BEAMS

\* Reader in Civil Engineering, University of Canterbury.

In many situations the shear strength of a shear wall appears to be the governing criterion. Therefore it is appropriate to review briefly our existing interpretation of the shear problem. In spite of tremendous efforts to explore fully all aspects of the shear strength of reinforced concrete beams we do not understand them as well as we do flexure. However, a complete break in our thinking, away from that associated with homogeneous isotropic materials, has been achieved.

The shear in uncracked concrete members is seldom a problem. The traditional concept of principal stresses appears to predict satisfactorily the tensile stresses which are responsible for the initiation of cracking. In beams of normal proportions flexure is the primary cause of cracking. When shear is present these cracks may incline. In flanged beams, with relatively thin webs, and in short deep beams, the first cracks may be the diagonal ones, which can form in the web and subsequently propagate towards the flanges.

Once substantial diagonal cracking has developed, the concept of shear stress must be abandoned. Stress equations are interpreted as giving only an index of shear intensity for an area of a beam where most of a shearing force is being resisted. After cracking various mechanisms may be available which are capable of transferring shear. Whether we allow for them or not in our strength computation, the existence of such mechanisms must be recognised.

#### 2.1 Beams without Web Reinforcement

Across a potential failure section, such as an extended diagonal crack, the shear force can be transmitted in three ways<sup>(1)</sup>. A part of the transverse force is transferred by shearing stresses in the compression zone and the remainder by means of aggregate interlock action along the crack and dowel forces across the flexural reinforcement. The mathematical models of analytical studies are, with few exceptions, based on the first mode of shear transfer. In most beams, however, aggregate interlock and dowel action accounts for at least 75% of the

shear strength. These actions, which will always be generated when shear displacements along cracks occur, must also be present in shear walls.

When the widening of diagonal cracks is not restricted, as is the case of unreinforced webs of slender beams, it is generally found that the ultimate shear strength is not much in excess of that load which caused diagonal cracking. On the other hand, for short beams, with a shear span to depth ratio of less than 2, considerable shear may be carried in excess of that causing cracking. Diagonal compression between load points, generally termed arch action, accounts for this. Adequate flexural reinforcement and its full anchorage are prerequisites of arch action. This mode of load transfer is more easily achieved in laboratory beams than in frame components because the load and reactions are generally applied to the top and bottom faces of a test specimen. When the shear is introduced by means of secondary members the favourable conditions for arch action do not exist. These two cases are illustrated in Fig. 1. It will be shown that this observation is very important in relation to shear walls.

The geometric dependence of arch action is usually expressed by the  $a/d$  parameter (see Fig. 1a). For a point loaded beam this is equivalent to the  $M_{max}/Vd$  ratio. In a cantilever, carrying a point load at its free end, the  $H/D$  ratio is usually considered as being the corresponding parameter. (See Fig. 4)

The shear strength of beams without web reinforcement depends primarily upon the tensile strength of the concrete. The failure, when it occurs, is of brittle nature. For this reason such members cannot be used in earthquake resistant structures.

## 2.2 Beams with Web Reinforcement

The mechanism of shear transfer, based on the analogy of a truss consisting of diagonal concrete compression members and tension members, formed by the web reinforcement, is familiar. This simple concept, introduced by Morsch at the turn of the century, has since been verified in numerous experiments.

The web reinforcement engages in load resistance only after the formation of diagonal cracks. The load resisted by the truss mechanism is generally the load in excess of that which caused diagonal cracking. This has been observed in a very large number of test beams. However, no satisfactory theory has been put forward so far to explain why the diagonal cracking load, and not a force substantially different from this, can be sustained by the mechanisms other than the web reinforcement.

It is now an accepted design practice to allocate a fraction of the external shear to the "concrete" and the remainder to the web reinforcement. However, the share of the concrete is assessed rather conservatively (3).

An important role of the web reinforcement, generally overlooked in the relevant literature, is that of crack control. Within the elastic range the web reinforcement inhibits the excessive opening of diagonal cracks and by

doing so it preserves the integrity of those mechanisms which sustain shear in a beam without web reinforcement. Stirrups arrest excessive crack propagation into the web or along the flexural reinforcement and thus enable aggregate interlock and dowel actions to remain operative. Alternatively, for short beams, they enable effective arch action to be maintained by preventing a diagonal splitting failure.

When the ultimate strength of the web reinforcement is attained these secondary, but by no means unimportant, effects cease to function. After yielding of the stirrups the diagonal cracks open very rapidly. In normal beams shear capacity due to aggregate interlock or crack friction is lost, and sudden collapse follows. Only negligible ductility can be observed. For this reason the web reinforcement must be so proportioned that it operates in the elastic range when the ultimate flexural capacity of the member is being approached.

In short beams the ultimate shear strength may be in excess of the sum of the diagonal cracking load and the strength of the web reinforcement. This excess strength may be derived from arch action when the loads are introduced suitably. However, arch action may tax the flexural strength of the beam by imposing large diagonal compression forces at the sections of maximum moments.

In thin webbed beams with flanges the diagonal compression, which is at least twice as much as the nominal shear stress corresponding with the shear force across the truss, may lead to diagonal crushing. Therefore an upper limit must be set to the desired web steel content in the same way as in the case of flexure, when a primary compression failure is to be avoided.

## 2.3 Repeated and Cyclic Loading

Most of the shear research was concentrated on simply supported beams under static loading. For this reason little information exists on those aspects which are particularly important in the assessment of seismic behaviour.

In the extensive research projects of Leonhardt and Walther (2) the development and possible widening of diagonal cracks for different types and amounts of web reinforcement was also observed. Several load repetitions, up to and above full dead and live load intensity, indicated that the load-stress pattern of stirrups becomes stable after a few load applications, and that a fraction of the shear can always be sustained by mechanisms other than the web reinforcement. This indicates that the important contribution of aggregate interlock action does not deteriorate as long as the web and flexural reinforcement do not yield.

Recent tests at the University of Canterbury, specifically designed to explore aggregate interlock action, verified this behaviour. After a certain amount of permanent shear displacement shear stresses of the order of 700 psi across a preformed crack were attained ten times without significant additional deformations. It is important to note, however, that this can be achieved only if cracks are prevented from opening. Therefore it may be said that,

within the elastic performance of the reinforcement in a beam, the three components of shear resistance, as outlined previously, remain operative even after several repetitions of high load intensity.

An excursion of the flexural reinforcement into the postelastic range can have serious consequences upon the shear strength of the affected area. As diagonal and flexural cracks cannot be separated, the widening of the latter, after yielding of the flexural reinforcement, can cause the widening of the diagonal cracks. With this the shear transfer by aggregate interlock drastically reduces or it vanishes. Thus the web reinforcement must be capable of accepting the additional shear force. It is for this reason that over the likely length of a possible plastic hinge, web reinforcement should be provided to resist the whole of the shear force.

In fig. 2a the shear force - stirrup strain history, observed in a deep beam during cyclic alternating loading, is presented\*. The drastic increase of strains in the stirrups were caused by widening cracks when the flexural steel yielded at the end of a load cycle. The strains generated at two points along the flexural reinforcement, as shown in Fig. 2b, can be related to the stirrup performance. The web reinforcement in this beam was provided to resist 104% of the shear generated when the theoretical flexural capacity was to be attained. The load  $P_1$  is expressed in terms of the theoretical ultimate capacity.

#### 2.4 Deep Beams

For want of other and better information it was often attempted to predict the likely behaviour of shear walls from tests carried out on deep beams. Geometric similarities suggested such a procedure. There were two notable groups of tests which were used in the present formulation of the clauses of the SEAOC<sup>(4)</sup> Code, related to the shear strength of shear walls.

The first test series, studied by Slater, Lord and Zipprodt in 1926, is of historical interest<sup>(5)</sup>. The 172 beams tested were to form a basis for the design of concrete ships during the first World War. Most of the beams were of I shaped cross section and contained various types of rather heavy web reinforcement. Nearly all specimens, centrally loaded over a simply supported span, could be classified as deep beams. Of particular interest was a 10 ft. deep beam spanning over 20 ft., i.e.  $a/d = 1.0$ . The 4" thick web contained No. 6 single stirrups at 4½" centres. The beam was subject to reversed load and to 40 repetitions of loading corresponding with  $v = 10 \sqrt{f'_c}$  nominal shear stress, the maximum presently allowed by the ACI Code<sup>(3)</sup>. Failure occurred under 1,360,000 lbs central load, generating a nominal shear stress of about 1500 psi ( $22 \sqrt{f'_c}$ ), in a form of explosive diagonal crushing. The web reinforcement ( $p_w = 2.5\%$ ) did not yield.

In 1965 de Paiva and Siess<sup>(6)</sup> reported on 19 moderately deep beams which carried two central point loads, applied to the top face of the beams, over a simply supported span.

These tests showed that considerable load can be carried after diagonal cracking by arch action. The addition of web reinforcement of up to 1.42% had little effect on ultimate strength.

Both groups of deep beams have the common feature, that the load was applied to the top and bottom faces of the test specimen, as shown in Fig. 1a. It was pointed out earlier that this considerably enhances the effectiveness of arch action. Stirrups crossing the main diagonal crack are not engaged in efficient shear resistance because no compression struts can form between their anchorages. The arch disposes of the shear along the shortest possible route. For this reason the shear will avoid the longer paths, via stirrups, which are associated with larger deformations. The failure is usually brought about by crushing of the concrete near the load point or splitting at the anchorages of the flexural reinforcement.

Two deep beams in a recent series of tests, carried out by Leonhardt and Walther at the University of Stuttgart<sup>(7), (8)</sup>, have particular relevance to shear walls. The loading, principal dimensions, crack pattern and the outline of the reinforcement for one of these beams is shown in Fig. 3. The important feature of the test is the mode of load application. This prevented the formation of a single compression diagonal between the load and reaction points. The crack pattern indicates that a substantial portion of the diagonal struts engage vertical stirrups and that the diagonal compression stresses are more uniformly distributed over the depth of the wall-beam. A comparison of its failure load with its ultimate capacity, as predicted by the ACI and SEAOC codes, is presented in Appendix A.

A number of deep beams, tested at the University of Canterbury, were subjected to high intensity alternating loading. The dimensions and the loading were such that the  $a/d$  ratio varied from 1 to 2. The shear and the equal moments were introduced at both ends of these specimens by means of massive end blocks<sup>(14)</sup>, which prevented the formation of an effective diagonal strut i.e. arch. The beams were so designed that shear stresses in excess of the maximum, currently permitted by the ACI code<sup>(3)</sup>, would have to be developed when the ultimate flexural capacities of the beams were being approached. Some of the beams were deliberately underreinforced for shear to enable diagonal tension failures to be studied. A comparison of the strengths of these beams with those predicted by the ACI<sup>(3)</sup> and SEAOC<sup>(4)</sup> codes is instructive. The results are presented in Table 1.

### 3. SHEAR WALLS

To enable a qualitative examination to be made of shear wall problems it is necessary to establish a classification. One such grouping is shown in Fig. 4. It shows only regular shear walls which occur commonly in multistorey structures. Certain features of these, related to shear strength, may be briefly discussed as follows:

Type A. With a  $H/D$  ratio larger than approximately 2.5 no deep beam effects would need to be considered. The wall could be expected to behave as a large beam, subject to flexure

\* For other details of Beam 244 see Table 1.

shear and moderate compression. The horizontal wall reinforcement would take the role of the stirrups.

Type B. With adequate flexural reinforcement a very large overturning moment would be required to cause yielding. This moment could heavily tax the shear capacity of such a wall. It is doubtful whether foundations could be provided to resist such actions without uplift. There is little known about the development of shear strength in such a wall with a small H/D ratio. The crack formation will be strongly affected by the mode of shear application. If this occurs in a reasonably uniform fashion along the slabs numerous cracks could be expected. This would account for the engagement of vertical web reinforcement. The most likely behaviour could best be assessed by an analogy to the deep beam shown in Fig. 3.

Type C. Theoretical considerations and observations of earthquake damage indicate that the spandrel beams, coupling solid shear walls, are the first ones to be damaged in a well designed structure. Each of the two walls may be considered to be of Type A. When the gravity load is small one of the walls may be subject to considerable tension. Under such an adverse load combination this wall is likely to shed some of the shear to the other wall, which is less likely to be affected by cracking. The only known experiment on a relatively large reinforced concrete specimen of this type has recently been reported from Rumania<sup>(9)</sup>. The crack pattern for two of these test walls is shown in Fig. 5. The behaviour of the spandrel beams has been examined in some detail at the University of Canterbury<sup>(10)</sup>.

Type D. This structure is similar to Type C except for the walls which are considerably weaker than the spandrel beams. The weak links are the short columns across which the x cracks can form. Their behaviour is likely to be very similar to that of the spandrel beams of Type C wall.

The flexural stiffness and strength of the first two types (A and B) may be considerably increased when flanges (return walls) are provided. In the last two walls the short and relatively deep spandrels or columns present the common and critical feature. The Mt. MacKinley<sup>(11)</sup> building, shown in Fig. 6. is a convincing example of both cases.

The relevance of these shear wall types to the previous discussion on shear and deep beams may be shown in three points:

(a) In all cases the lateral shear is introduced to the walls through line loads along the floor slabs. There is very little, if any, resemblance to deep beams subject to face loading. In none of these shear walls can arch action develop to the same measure as in the face loaded test beams.

(b) The shear is similarly introduced, in a continuous form, at the boundaries of the spandrels and short columns. The beneficial arch action, associated with face loading, can not develop. The familiar x cracks observed in numerous buildings<sup>(11)</sup> and in laboratories<sup>(10)</sup> offer a unique evidence of this. If significant diagonal compression existed, these cracks, which divide the deep elements into triangular

halves, would have to close.

(c) As no reliance can be placed on diagonal compression, generated by arch action, the conventional web reinforcement must be considered as the only effective shear resisting device irrespective of the geometry (H/D) of a wall. It may consist of stirrups or diagonal bars supplemented by intermediate longitudinal reinforcement.

#### 4. A CRITICAL EXAMINATION OF THE SEAOC CODE

It is likely that many engineers in New Zealand will use the recommendations of the SEAOC<sup>(4)</sup> code also, where these refer to shear walls. This document follows generally the clauses of the current ACI code<sup>(3)</sup> which has made no specific rules on shear walls.

With the intention to provide a greater range of elastic response in any given dynamic input prior to possible non-ductile shear failure, the SEAOC code imposes rather severe limitations on the intensity of nominal shearing stresses. The first and more severe requirement is the doubling of the load factor, when applied to seismic shear forces. The second set of limitations are represented by equations in which the height to depth (H/D) factor is the major parameter. For convenience these are shown by graphs in Fig. 7. It may be seen that for squat walls the contribution of the web reinforcement is assumed to gradually diminish. The severity of these rules, particularly when compared with the ACI shear requirements, is apparent. In formulating these rules the SEAOC apparently considered mainly the face loaded deep beams<sup>(5)</sup> <sup>(6)</sup>, which were described previously. With respect to Fig. 7 four points deserve comment:

1. The web reinforcement need only be nominal when  $H/D \leq 1$ . This implies that the concrete is expected to resist the whole of the seismic shear, irrespective of the state of cracking. It was pointed out earlier that in deep members, where the shear is applied over the whole depth, the beneficial effect of arch action is not available. This means that failure may occur shortly after the formation of a diagonal crack, as in normal beams. The nominal shear reinforcement may provide little additional strength. In fact the ultimate shear strength of such a wall may be less than that of a similar but higher wall. For example the ultimate shear strength of a wall with  $H/D = 1$  and  $m = 0$  is likely to be less than that of a wall with  $H/D = 3$  and  $m = 3.7$ , all other factors being equal. Because of the absence of effective arch action the SEAOC approach to the shear strength of squat walls appears to be unconservative.

2. There is no evidence to indicate that a shear wall with a particular web steel content and aspect ratio would ensure a better performance (i.e. a wall with  $m = 4$  and  $H/D = 2$ ).

3. Many shear walls may carry considerable gravity loads. The code does not allow for any benefit to be derived from the axial compression for shear resistance.

4. In certain situations the adherence to this code may lead to anomalous solutions. To illustrate this an example is shown in Appendix B<sup>(13)</sup>. A shear wall for a three storey proto-

type building is to be at least 15 in. thick if it is to conform with the code. If two additional storeys are added, the wall thickness need not be increased in spite of 54% load increase. It is not convincing that an equal measure of protection against shear failure is present in both cases.

The new ACI 318 code proposal<sup>(12)</sup> includes for the first time definite recommendations for deep beams which are loaded at the compression faces. Deep beams loaded over their full depth should be treated as ordinary beams. There are few specific recommendations with respect to the shear strength of shear walls. In the commentary of the code reference is made to a case when shear stresses in excess of  $12 \sqrt{f'_c}$  have been attained.

The last column of Table 1 shows the comparison of the actual failure load and the SEAOC requirements for 13 deep beams, when the factor of 2 is disregarded in the shear load factor. Whereas a consistently satisfactory agreement was found with the ACI predictions (Col. 10) the SEAOC requirements appear to be increasingly conservative as the H/D ratio decreases. It also shows that the local increase in strength for H/D = 2 (see Fig. 6 and point 2 above) is not justified.

It is likely that some of these anomalies will be eliminated during the next revision of the SEAOC code<sup>(13)</sup>.

#### 5. FUTURE RESEARCH

From the review of various aspects of shear wall behaviour, it must be evident that our present state of knowledge falls short of that of reinforced concrete frames. The code recommendations that do exist are based on face loaded deep beam experiments. The behaviour of these substantially differs from that of shear walls.

The few tests that simulated conditions which are likely to occur in shear walls or wall components of multistorey buildings indicate that dramatic brittle failures can be avoided. With certain precautions substantial ductility can be attained. There is some indication that the pessimistic view on shear walls, with respect to seismic loads, need not be maintained.

A considerable volume of research work needs to be done in this field. It is essential to explore every aspect of the shear wall performance under seismic conditions. Some of the more important points which need experimental verification are:

(1) The development of flexural and shear strengths in squat elements. Our present approach to the assessment of flexural strength may be optimistic when applied to deep members.

(2) Energy absorption characteristics of pierced walls.

(3) The damping properties of deep members in which shear is significant.

(4) Stiffness degradation and loss of strength, if any, as effected by high intensity alternating loading.

(5) The types of damage and the means of

avoiding the undesirable ones.

(6) The classification of prototype walls for which different design procedures may have to be developed. Height to depth ratio, shape of the cross section and the arrangement of openings could be the major factors in such a classification.

It is the intention to study some of these problems at the University of Canterbury. The existing test frame<sup>(14)</sup>, in which coupling beams of shear walls were examined, will be used to load small scale shear walls with small aspect ratios. The simulated load conditions are illustrated in Fig. 8. It is intended to determine the desirable amount of shear reinforcement to ensure the maximum obtainable ductility, and the effects of cyclic loading. A realistic flexural steel content, typical for a shear wall, will be used.

#### 6. DESIGN RECOMMENDATIONS

From the foregoing discussion certain design recommendations, with respect to the shear strength of shear walls, suggest themselves.

1. The careful consideration of shear strength should not distract from the attention to be paid to flexure. The strength and the post-elastic performance of shear wall must be governed by flexure. In this respect walls with H/D larger than 2 are likely to behave as large doubly reinforced concrete beams with ample ductility.

2. The benefit that may be derived in deep beams from arch action, as a major shear resistant mechanism after cracking, should be disregarded. The shear resistance of various mechanisms, other than the web reinforcement, should be assessed as in an ordinary beam, i.e.  $V_c = 2bd \sqrt{f'_c}$ . Web (horizontal) reinforcement should be provided for the remainder of the seismic shear.

3. The combined shear resistance, i.e.  $V_u = V_c + V_s$ , should be larger than the shear generated at the attainment of the maximum moment. Yielding of the web reinforcement should not occur.

4. Where diagonal cracks could open, as a consequence of yielding in the flexural reinforcement, the whole of the seismic shear should be resisted by suitable shear reinforcement. The height of the shear wall affected by this requirement could be equal to its depth.

5. Vertical reinforcement placed in the core of shear walls, irrespective of this being nominal or not, must be included in the assessment of the ultimate flexural strength, at its true yield strength, to ensure that the shear strength provided is not exceeded. Apart from improving crack control and providing dowel resistance, vertical web reinforcement in shear walls is not likely to contribute towards shear strength.

#### REFERENCES

- (1) Fenwick, R. C. and Paulay, T.: "Mechanisms of shear resistance of concrete beams", Journal of the Structural Division, ASCE,

Vol. 94, No. ST10, Paper 6167, October 1968, pp. 2325-2350.

- (2) Leonhardt, F. and Walther, R.: "The Stuttgart Shear Tests, 1961" Cement and Concrete Association, Library Translation No. 111, p. 134.
- (3) - ACI318-63 Building Code Requirements for Reinforced Concrete.
- (4) - Recommended Lateral Force Requirements and Commentary", Seismologic Committee Structural Engineers Association of California (SEAOC) 1968 Revision.
- (5) Slater, A. W., Lord, A. R. and Zipprodt, R. R.: "Shear Tests of Reinforced Concrete Beams" Department of Commerce, Bureau of Standards, Technologic paper No. 314, 1926 pp. 387-495.
- (6) de Paiva, H.A.R. and Siess, C. P.: "Strength and Behaviour of Deep Beams in Shear", Journal of the Structural Division, ASCE, Vol. 91, No. ST5, October 1965, pp. 19-44.
- (7) Leonhardt, F. and Walther, R.: "Wandartige Traeger", Deutscher Ausschuss fuer Stahlbeton, No. 178, 1966.
- (8) Leonhardt, F.: "Poutres-Cloisons, Structures planes chargees parallelement a leur plan moyen" Comite Europeen du Beton, Bulletin No. 65, February 1968.
- (9) Branzan, I.: "Berechnung von Stahlbetonscheiben mit einer Offnungsreihe im plastischen Bereich", Die Bautechnik, Vol. 46, Dec. 1969, pp. 415-418.
- (10) Paulay, T.: "The Coupling of Reinforced Concrete Shear Walls" Proceedings 4th World Conference on Earthquake Engineering, Santiago, Chile, Jan. 1969, B-2, pp. 75-90.
- (11) Berg, V. B. and Stratta, J. L.: "Anchorage and the Alaska earthquake of March 27, 1964", American Iron and Steel Institute, New York, 1964.
- (12) - Proposed Revision of ACI318-63 Building Code Requirements for Reinforced Concrete, ACI Journal, Proceedings, Vol. 67 No. 2, Feb. 1970 pp. 77-188.
- (13) Fratessa, P. F., H. J. Degenkolb and Associates, San Francisco, Private Communication.
- (14) Paulay, T.: "Reinforced Concrete Shear Walls", New Zealand Engineering, Vol. 24, No. 10, Octo. 1969, pp. 315-321.

TABLE 1. A COMPARISON OF THE SHEAR STRENGTH OF DEEP BEAMS

1	2	3	4	5	6	7	8	9	10	11	12
Beam Number	$\frac{H}{D}$	$V_c$ ACI	$V_s$ ACI	$10\sqrt{f'_c}$ ACI	$V_u^*$ ACI	$P_u^*$	$V_u^*$ SEAO	$V_u$	$V_u/V_u^*$ ACI	$V_u/V_u^*$ SEAO	$V_u/2V_u^*$ SEAO
	-	Kips	Kips	psi	Kips	Kips	Kips	Kips	-	-	-
241	2.00	19.9	20.3	594	40.2	81.0	22.9	63.6	1.58	2.78	1.39
242		23.7	62.0	742	85.7	86.0	47.0	89.0 <sup>+</sup>	1.04	1.90	.95
243**		22.1	62.0	674	84.1	84.0	42.6	83.7 <sup>+</sup>	1.00	1.96	.98
244**		23.3	89.0	726	92.1	85.3 <sup>‡</sup>	46.3	91.0 <sup>+</sup>	1.06	1.96	.98
311	1.29	30.0	83.4	730	113.4	158.0	41.0	146.2	1.29	3.56	1.78
312**		29.3	115.7	712	120.7	157.0	40.2	137.5	1.13	3.42	1.71
313**		32.5	192.0	830	140.0	160.0	46.6	144.2	1.03	3.10	1.55
314**		32.7	192.0	832	140.6	189.0	46.7	165.4	1.17	3.54	1.77
315**		30.7	190.5	742	125.2	184.0	41.8	174.0	1.39	4.16	2.08
391	1.02	34.3	112.0	678	146.3	205.0	40.0	174.5	1.19	4.36	2.18
392**		36.8	112.0	736	148.8	208.0	43.5	166.5	1.12	3.84	1.92
393**		33.3	166.0	666	144.0	216.0	39.5	160.0	1.11	4.06	2.03
394** <sub>o</sub>		38.5	247.5	802	174.0	237.5	47.5	233.9	1.37	4.92	2.46

Notes: \*\*Beams subject to alternating cyclic load.

Col. 1. The first two numbers indicate the depth of beam in inches. All beams were 6 in. wide.

Col. 2. Span to depth ratio.

Col. 3.  $V_c = 2bd\sqrt{f'_c}$

Col. 4.  $V_s = A_f d/s = p_w f_y bd$

Col. 5. The maximum nominal shear stress allowed by the ACI Code.

Col. 6.  $V_u^* = V_c + V_s$  or  $V_u^* = 10bd\sqrt{f'_c}$  whichever is smaller.

Col. 7. The theoretical ultimate load on the beam based on its flexural strength.

Col. 8. The ultimate shear according to Fig. 6.

Col. 9. The actual failure load.

Col. 10. A comparison with the ACI prediction.

Col. 11. A comparison with the SEAO requirement

Col. 12. Same as above but not including the additional load factor of 2.

φ The capacity reduction factor is omitted throughout.

+ Flexural capacity attained.

‡ Flexural strength governs.

o Confining reinforcement at the four corners was also provided.

APPENDIX A

A COMPARISON OF DESIGN PROCEDURES WITH A TEST BEAM  
(See Fig. 3)

Properties:  $\frac{H}{D} = \frac{L}{2D} = \frac{3.92}{5.25} = .75$        $b = 4''$        $d = 55.5''$

Flexural Steel Content       $p = .66\%$        $f_y = 60,000$  psi

Web Steel Content       $p_w = .66\%$        $f'_c = 4,100$  psi

Failure Load = 270 Kips       $v_u^* = 135000/4 \times 55.5 = 608$  psi

Shear Strength:

(a) SEAOC CODE

$$v_u = v_c = \frac{1}{2} \times 5.4 \phi \sqrt{f'_c} = .5 \times 5.4 \times .85 \sqrt{4100} = 147 \text{ psi}$$
$$= .242 v_u^*$$

(b) ACI CODE

$$v_c = 2\phi \sqrt{f'_c} = 2 \times .85 \sqrt{4100} = 109 \text{ psi}$$

$$v_s = \phi p_w f_y = .85 \times .0066 \times 60000 = \frac{336}{445} \text{ psi}$$

$$.735 v_u^*$$

APPENDIX B

THE MINIMUM THICKNESS OF A SHEAR WALL USING THE SEACOC RECOMMENDATIONS

The geometry and the loading are shown in Fig. 9.

The material properties are  $f_c = 3600$  psi and  $f_y = 40,000$  psi.

The base shear is assumed to be as follows:

(NZS 1900, Ch. 8, Zone A)

$$3 \text{ storeys } V_3 = .120 \times 4100 = 492^k$$

$$5 \text{ storeys } V_5 = .115 \times 6600 = 759^k$$

For shear design for ultimate strength the load factor of

$$1.4 \times 2.0 = 2.8 \text{ and } \phi = .85 \text{ are used. } d = 27'6''$$

The relevant quantities are shown in the table below:

Wall Type	H/D	$v_c$	$v_u$	$v_s$	$V_u$	t	$p_w$
	-	psi	psi	psi	Kips	in	%
3 storey	1.00	275	275	-	1377	15.2	.025
5 storey	1.67	207	433	226	2125	14.9	.992

Note:  $v_c = (3.7 - \frac{H}{D}) 2\phi\sqrt{f'_c}$  ;  $v_u = (0.8 + 4.6 \frac{H}{D})\phi\sqrt{f'_c}$

$$p_w = \% \text{ web steel content} = 100 v_s / \phi f_y (H/D - 1)$$

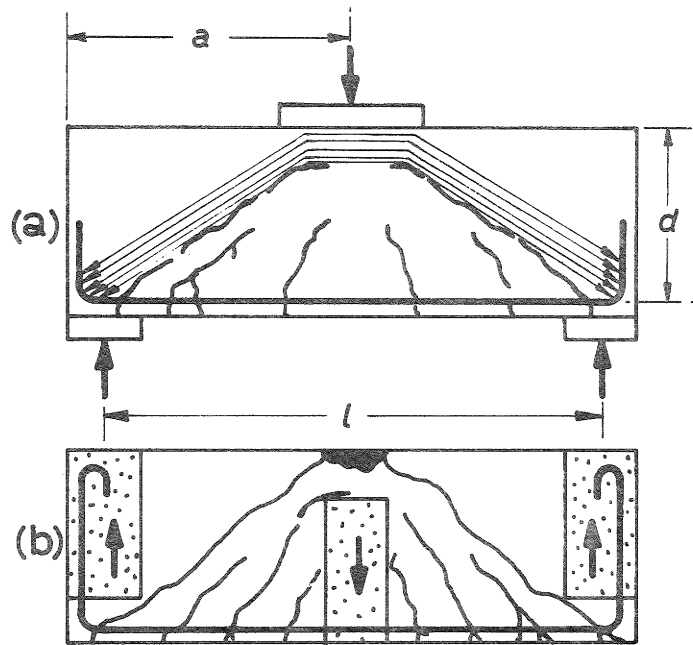

Fig. 1. Arch Action as Affected by the Introduction of Load into a Beam.

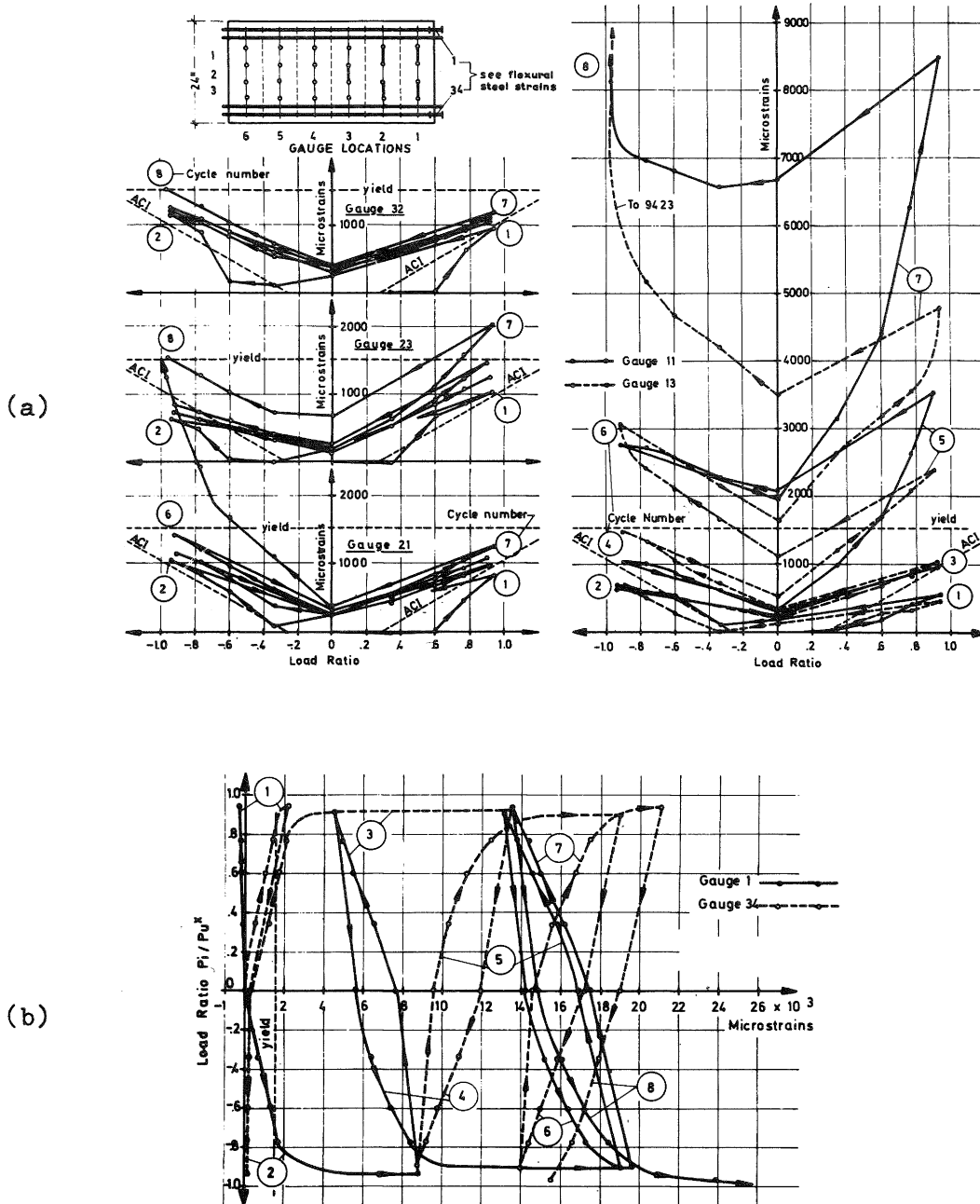

Fig. 2. The Load-Strain relationship for the (a) stirrups (b) flexural reinforcement during cyclic loading of a coupling beam. (Beam 244).

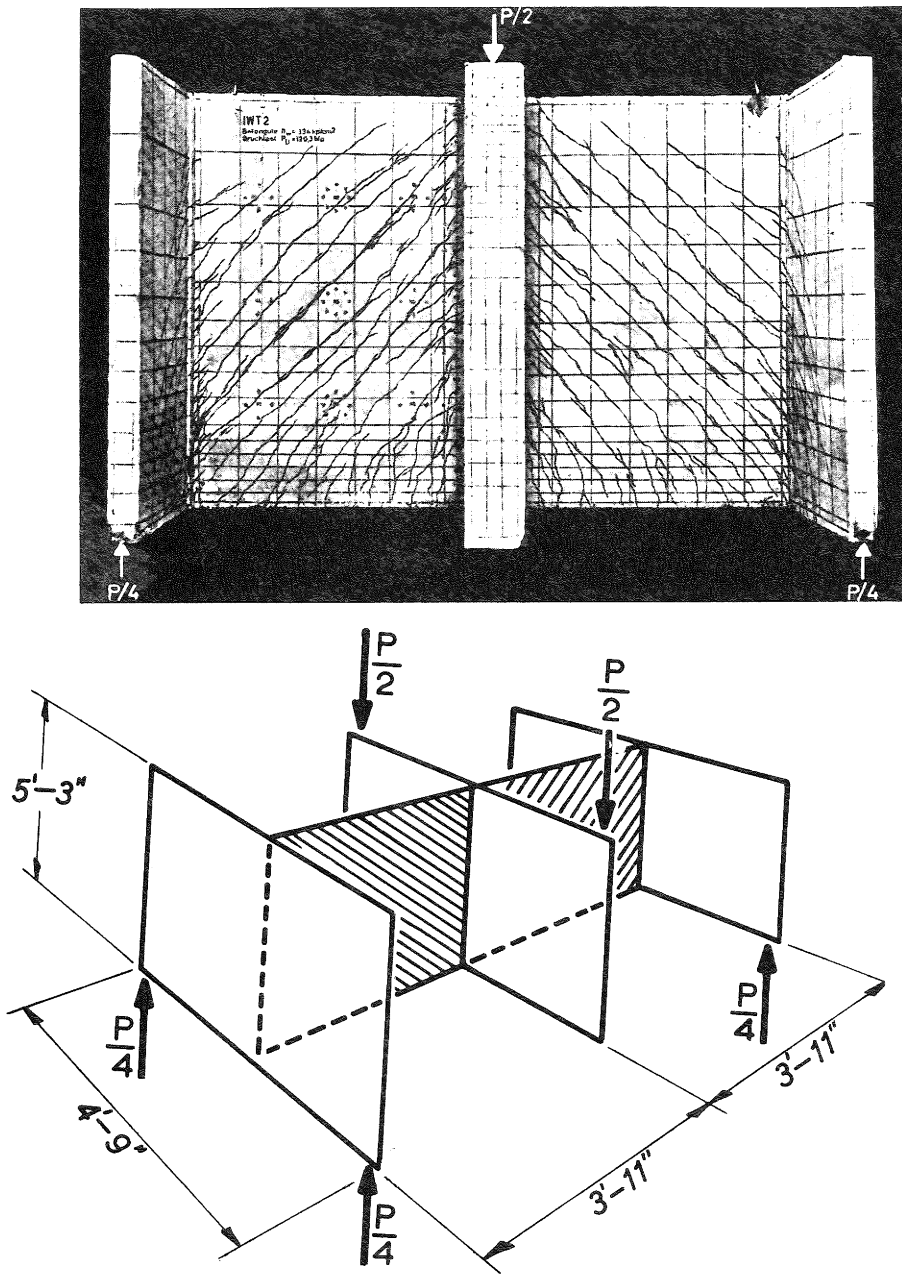

Fig. 3. The Loading and Crack Pattern of a Deep Beam.<sup>(7)</sup>

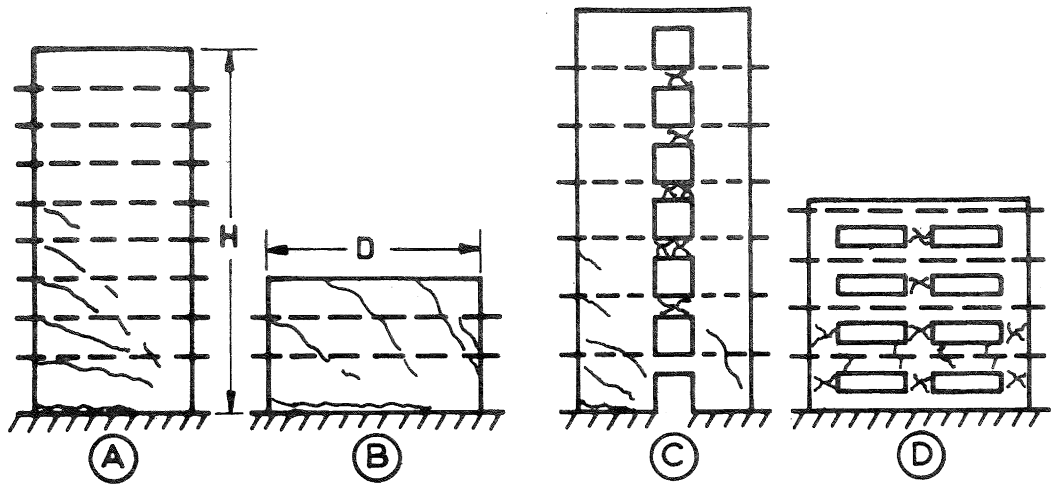

Fig. 4. Types of Regular Shear Walls in Multistorey Buildings.

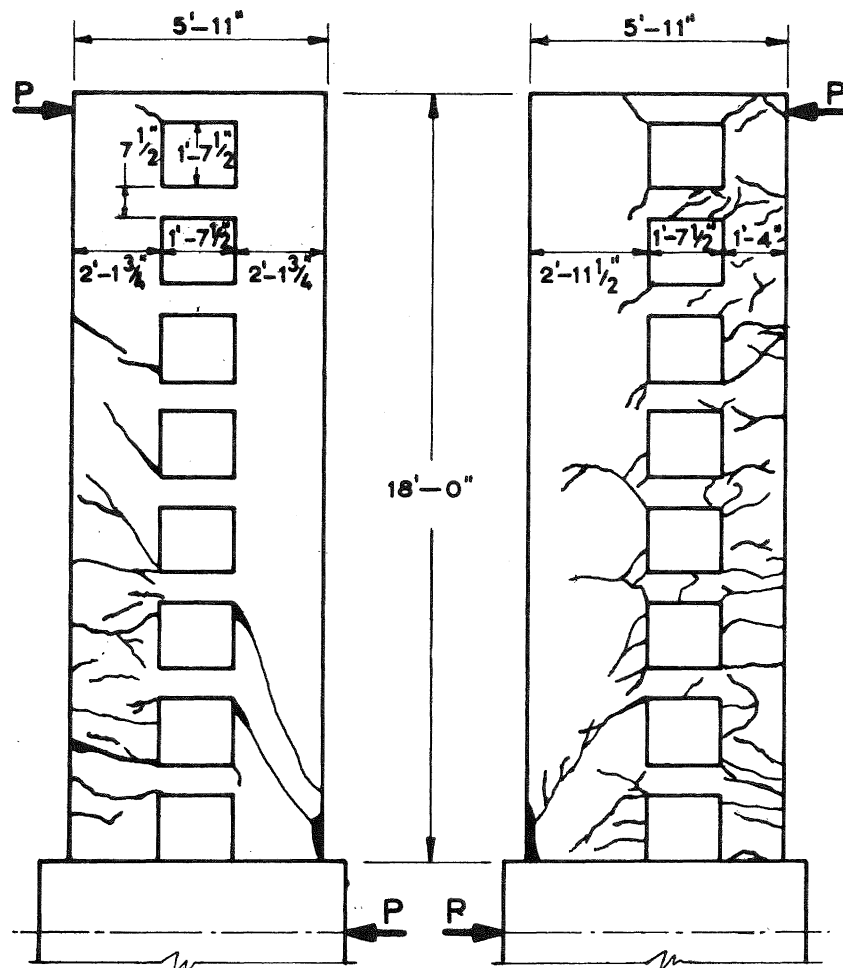

Fig. 5. The Crack Pattern in two Reinforced Concrete Shear Wall Models. (9)



Fig 6. The Mt. McKinley Building in Anchorage, Alaska. (11)

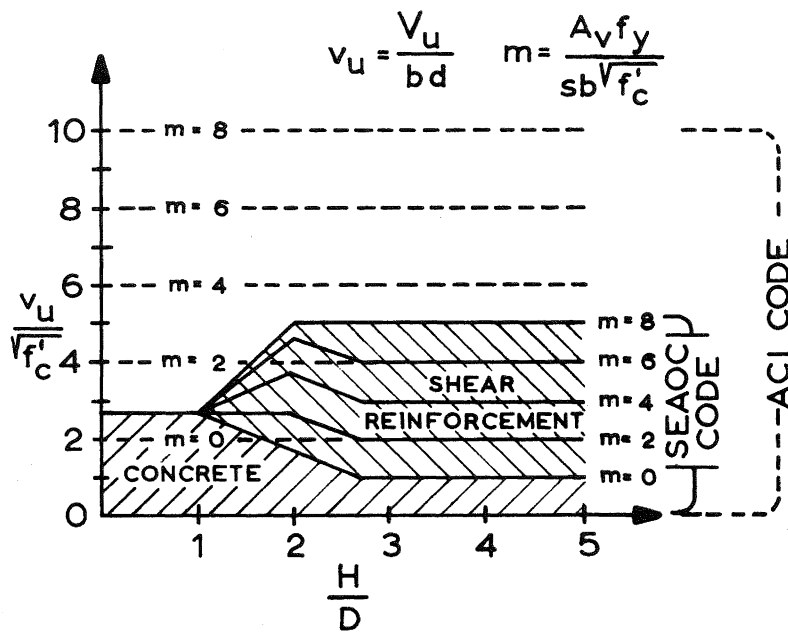

Fig. 7. A Comparison of the Shear Strength Requirements of the SEAOC and ACI Codes.

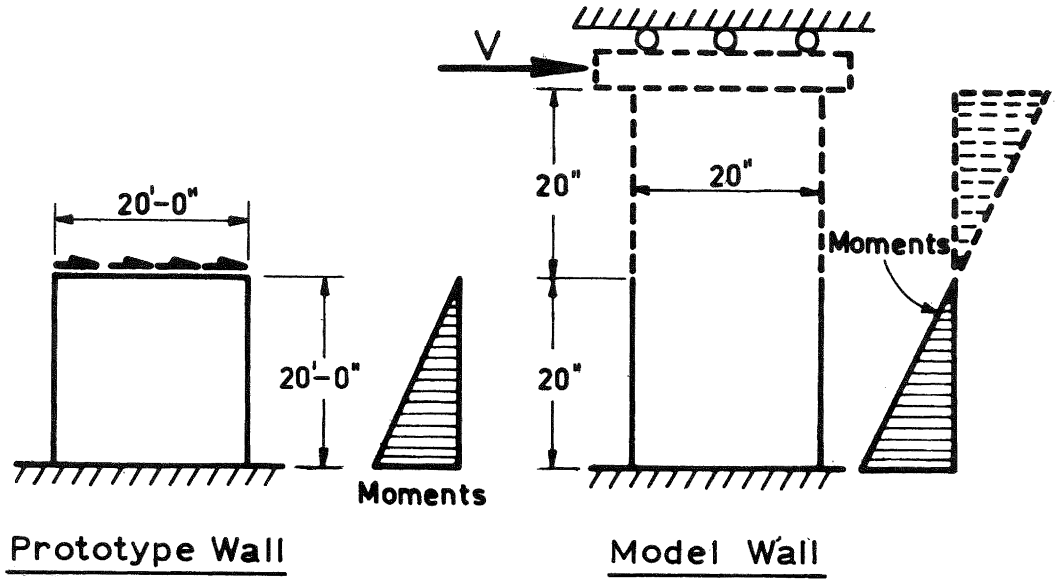

Fig. 8. Prototype and Model Walls for a Test Program.

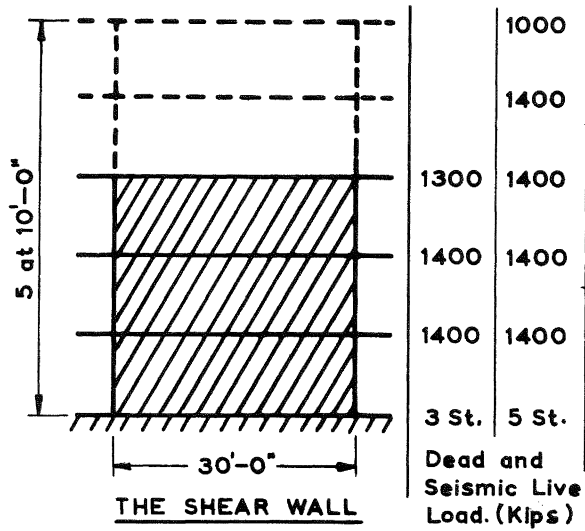

Fig. 9. The Geometry and the Loading of an Example Shear Wall.