

# EARTHQUAKE DAMAGE AT EDGE CUMBE AND KAWARAU ELECTRICORP SUBSTATIONS IN THE BAY OF PLENTY EARTHQUAKE ON 2 MARCH 1987

A. L. Rutledge\*

## SUMMARY

This paper describes the major damage to Edgcumbe and Kawarau substations in the Bay of Plenty earthquake on 2 March 1987. Questions such as why the equipment failed and what actions should be taken to strengthen the equipment are addressed.

Editor's Note : This paper was first published in the Transactions of the 58th Annual Conference of the Electric Supply Authority Engineers' Institute of New Zealand Inc., vol. 57, 1987 and is reprinted with their permission.

## INTRODUCTION

The Electricity Corporation (formerly Electricity Division) has specified relatively high seismic design factors for new electrical equipment since 1968 and has also upgraded many of the more important older installations, especially in the HVDC link, where a better understanding of earthquake effects has indicated weaknesses.

The substation damage sustained in the Bay of Plenty earthquake was confined mainly to equipment installed before 1968 and was a timely reminder that all older substations should be checked for resistance to earthquakes and upgraded when necessary.

In many instances upgrading can be easily carried out and the relatively low cost of the modifications is not difficult to justify. At Edgcumbe and Kawarau a large proportion of the total cost of the damage was due to inadequate holding down of transformers which had originally been designed to only 0.15g. If the transformer fixings had been upgraded to the present requirement of 0.75g it is likely that most of the transformer damage would have been avoided, at a comparatively small cost.

## THE EARTHQUAKE

The main shock on 2 March measured 6.3 on the Richter Scale with an epicentre near the town of Edgcumbe and an epicentral depth of about 10km [1]. Four aftershocks with magnitudes in excess of 5.0 occurred later in the day.

The main shock produced a complex surface scarp about 6km long striking SW from near Edgcumbe. About 1m of extension occurred across the scarp with the area to the northwest being downthrown by about 1.5m.

\* Formerly Earthquake Engineer,  
Electricity Corporation, Wellington

Strong motion accelerographs recorded peak ground accelerations of up to 0.33g at the base of the Mdatahina dam, 15km from the epicentre. Processing of the strong motion data by the DSIR Physics and Engineering Laboratory has produced a response spectrum surprisingly like the 1940 El Centro N-S spectrum. Response spectra are given in Figure 1.

The earthquake was therefore quite representative of the Electricorp design earthquake for which the El Centro 1940 N-S is one of the 8 component spectrum.

## DESCRIPTION OF DAMAGE

Edgcumbe and Kawarau substations were extensively damaged [2]. Detailed inspections revealed that much of the damage was avoidable if better workmanship and current design practices had been used for the holding down of control panels and transformers.

### Control Panels

The control and relay room at Edgcumbe had three parallel rows of 2140mm high x 450mm deep x 600mm wide control panels down on a wooden plinth (NZ Oregon) by 8mm coach screws. Although the panels were tied longitudinally and laterally with 25mm x 25mm x 6mm angle iron they were not braced to the walls. All three rows pulled the coach screws from the wood and fell forward like dominoes until the front row struck the operators cubicle.

Coach screws offer little resistance to overturning and this method of securing panels is no longer standard Electricorp practice. The current practice is to bolt panels to a Unistrut support system as in Figure 2. Some older existing panels on wooden plinths at other Electricorp substations have been strengthened by tying

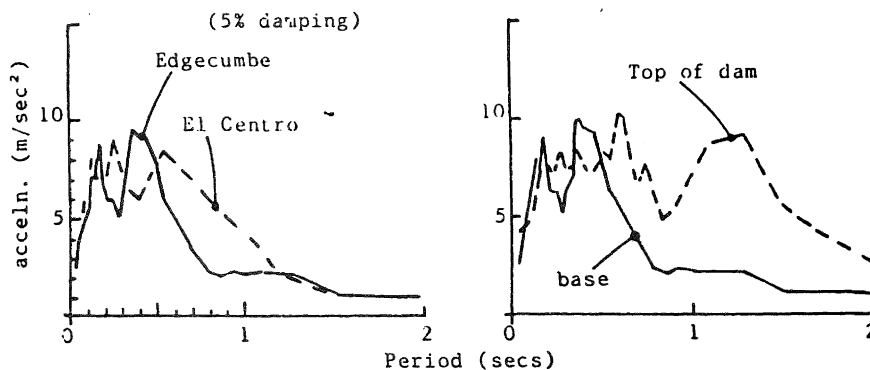

FIGURE 1 RESPONSE SPECTRA AT THE MATAHINA DAM FOR THE EDGECUMBE EARTHQUAKE

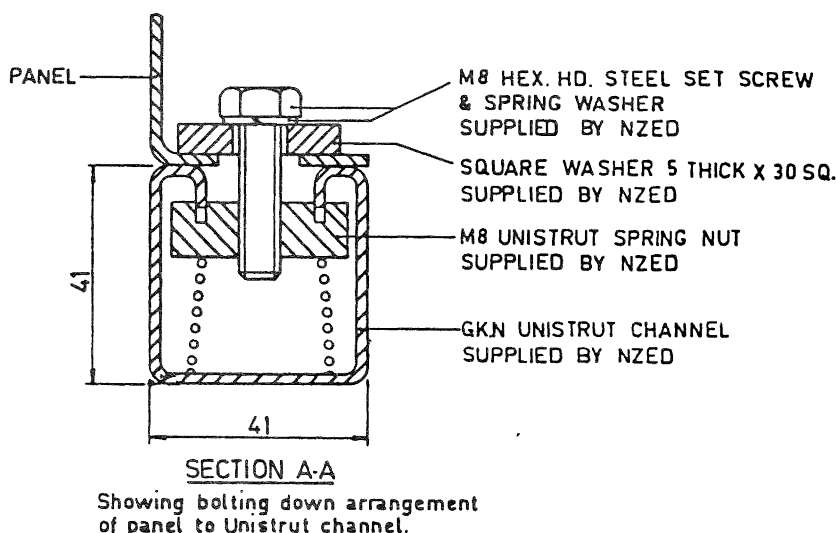

FIGURE 2 UNISTRUT SUPPORT SYSTEM FOR PANELS

together at the top and bracing securely to a structural wall.

At Kawerau three control panels out of 35 fell over. The panels are of modern construction 2100mm high x 600mm deep x 600-800mm wide and are secured to the floor via a Unistrut support system. The panels which fell over were installed with 10mm countersunk screws without washers instead of the hexagonal bolts and large flat washers specified in the original design. The countersunk heads pulled easily through the cabinet base allowing the panels to topple.

Fortunately at both Kawerau and Edgecumbe the damage to the panels and instruments was fairly minimal and there was sufficient slack in the control cables to accommodate the rotations at the panel bases.

Water Tanks

The two water tanks at Edgecumbe were about three-quarters full at the time of the earthquake. The sloshing action of the water buckled the iron roof of the tanks but the tanks and roof support structures, were undamaged.

Spares

In the 80 ton Edgecumbe workshop three out of six unsecured spare 110kV CTs still in their shipping crates fell over (Figure 3). Crates of tools, nuts, bolts and other miscellaneous items were also spread around the workshop floor by the earthquake. The importance of securing spares adequately and good housekeeping practice in general is self evident.

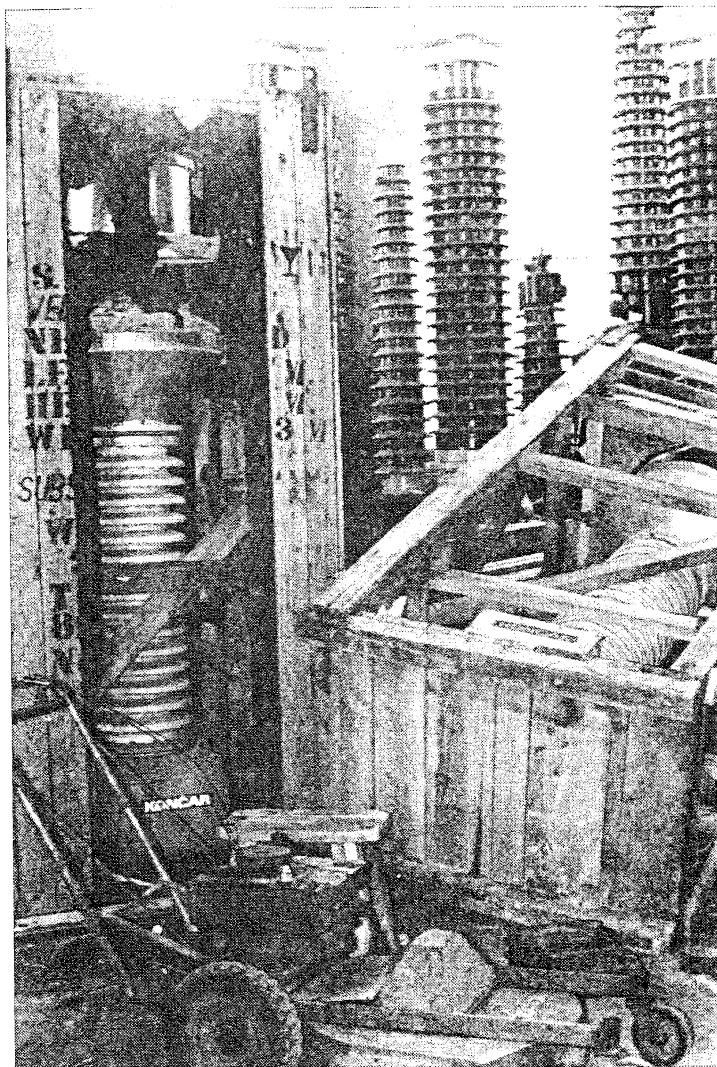

FIGURE 3 SPARE CTS TOPPLED OVER IN THEIR CRATES

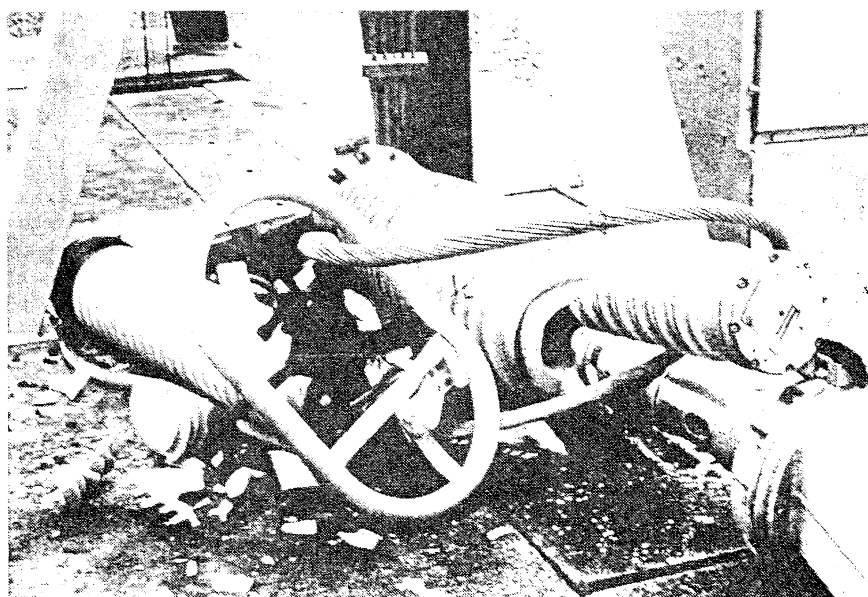

FIGURE 4 220KV CIRCUIT BREAKER AT KAWARAU DESTROYED

At Kawerau the storeroom within the central building was less affected apart from three gas cylinders which broke the chain securing them to the wall.

#### Current Transformers

Seven out of 12 Rade Koncar type APU245 current transformers in the Kawerau 220kV switchyard leaked oil after the earthquake. The cause of the leakage was stretching of the clamping bolts at the base of the porcelain. When the CTs were stripped for inspection the support system for the internal windings was also found to be damaged. Clearly the strength of the end fixing arrangement of the porcelain and the strength of the internal Windings support system need to be considered as well as the cantilever strength of the porcelain in the overall assessment of the earthquake resistance of CTs.

At Edgcombe three 110kV Brown Boveri CTs cracked at the base of the porcelain and allowed oil to escape. A contributing factor to the failures may have been grinding of the porcelain and stress concentration at the base clamping arrangement, as in the CT failures at Tokaanu substation in March 1984 [3].

A Balteau 220kV CT at Edgcombe was also damaged when the adjacent circuit breaker CB482 failed and pulled on the flexible connection to the CT.

#### CVTs

Only one CVT failed and that was a relatively old design ASEA type CT 08 1/22 at Edgcombe. The failure occurred at the base of the capacitor support which is a brittle cast iron component. This weakness in the design could easily be corrected by replacing the bottom two castings with fabricated I-beam sections.

#### Circuit Breakers

In the Kawerau 220kV switchyard the blue phase of CB622, a Merlin Gerin 220kV FA2 CB was totally destroyed (Figure 4). Failure occurred at the base of the top support insulator. The falling interrupter head then broke the support insulator of the adjacent isolator 624.

The Merlin Gerin CBs were installed in 1979 and the design met Electricorp current earthquake design specifications. It is likely that the "tight looking" flexible connection to the isolator caused extra shock loading on the circuit breaker [4].

In the Edgcombe 220kV switchyard all six porcelain support columns of the Oerlikon 220kV type FS9C1 CB broke. The classic cantilever bending failure occurred at the base of a weak porcelain column supporting a heavy interrupter head. The Oerlikon breaker is on the list of Electricorp circuit breaker types to be strengthened.

In the Kawerau 110kV switchyard the red phase upper bushing of CB122, on ASEA 110kV circuit breaker was pulled off its supporting insulator completely, shearing

the four mounting bolts. The cause of this failure was probably insufficient flexibility in the electrical connections.

#### Line Traps

All line trap support insulators survived. However, at the north end of the Kawerau 220kV switchyard the insulator terminals on top of the red and blue phase units were broken. The failure was due to relative movement between the line trap and the solid tubular conductor. This damage would not have occurred if a properly designed flexible connection had been installed.

#### Transformer Holding Down

There were two basic modes of failure of transformer holding down arrangements at both Kawerau and Edgcombe:

- 1) Failure of the transformer undercarriage to rail fastenings.
- 2) Failure of transformer tank to undercarriage fastenings.

An example of the first mode of failure is shown in figure 5 where all the Metropolitan-Vickers 110kV spare transformers at Edgcombe sheared the 16mm bolts securing the holding down brackets to the undercarriage and the rail. As a result the transformers came completely off the rails.

The original holding down brackets are several times taller than the horizontal spacing of the 16mm bolts. Therefore horizontal earthquake load in the direction of the rails subjected the 16mm bolts to very high shear forces. The brackets were also only originally designed for 0.25g.

Another example of the first mode failure is the 8g7 tonne 210kV BTH bank at Edgcombe where failure of the 20mm bolts securing the holding down brackets to the rails allowed the yellow and red phase units to roll along the rails and ram their respective radiator support structures. Consequently the oil pipes between the radiator and transformer were destroyed. The holding down brackets were again only designed for 0.25g.

A third example of the first mode of failure is the Kawerau 110kV ASEA T1 and T3 banks where the holding down arrangement to the rails was overstressed. The weakest part of the design is the 20mm x 150mm long bolt through the rail. The bolt was subjected to high bending stresses under the action of combined horizontal and vertical load and the final fracture was tensile. Consequential failure of low voltage bushings with tap changer mechanisms occurred when the transformers moved on their rails.

An example of the second mode of failure is the Kaweruu T2A and T2B Feranti 110kV banks where the M16 bolts securing the transformers to their undercarriages failed in shear as in Figure 6.

The Kawerau T5 AE1 110kV transformer to undercarriage fixings were also badly designed and the holding down bolts failed in bending.

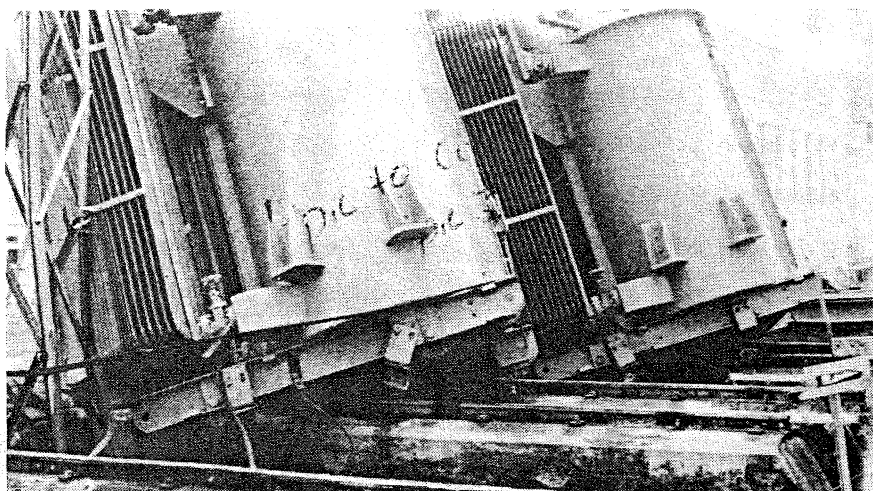

FIGURE 5 110KV TRANSFORMERS AT EDGE CUMBE OFF THEIR RAILS

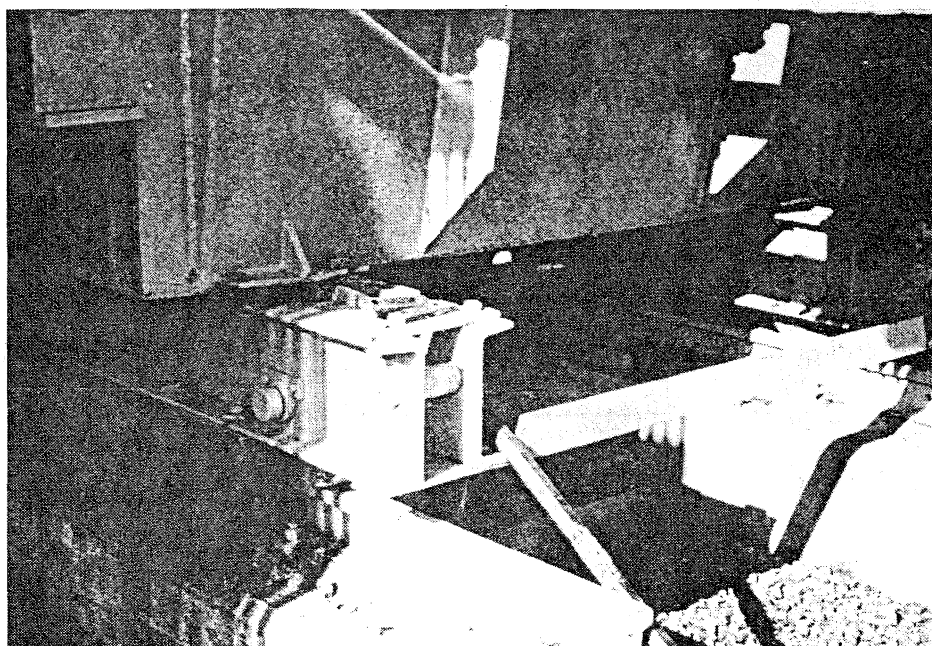

FIGURE 6 110KV TRANSFORMER AT KAWARAU SHEARED UNDERCARRIAGE/TRANSFORMER BOLTS

At Edgecumbe the M16 bolts securing the spare Ferranti 110kV transformer to the undercarriage sheared and came to rest against the adjacent Metropolitan-Vickers transformer.

Some transformers suffered both modes of failure. For example, all Savigliano 210kV T8 transformers at Edgecumbe including the spare came off the rails when the holding down arrangements failed completely. Most of the 20mm studs securing the holding down brackets to the wheels failed in shear as in Figure 7. The studs were subjected to extremely high shear loads because of the

lever action of the relatively long brackets on the narrowly spaced studs as in Figure 8. Even if the transformer wheels had been adequately fastened to the rails the transformers would not have survived because of the weak attachment of the undercarriage to the transformer tank. Several of the wheels were ripped off either when the transformers left the rails or when they hit the concrete. The holding down arrangements for the Savigliano transformers were designed to 0.25g. When the transformers are reinstalled they will be bolted directly to the foundation pad.



FIGURE 7 220KV TRANSFORMER AT EDGE CUMBE OFF THE RAILS

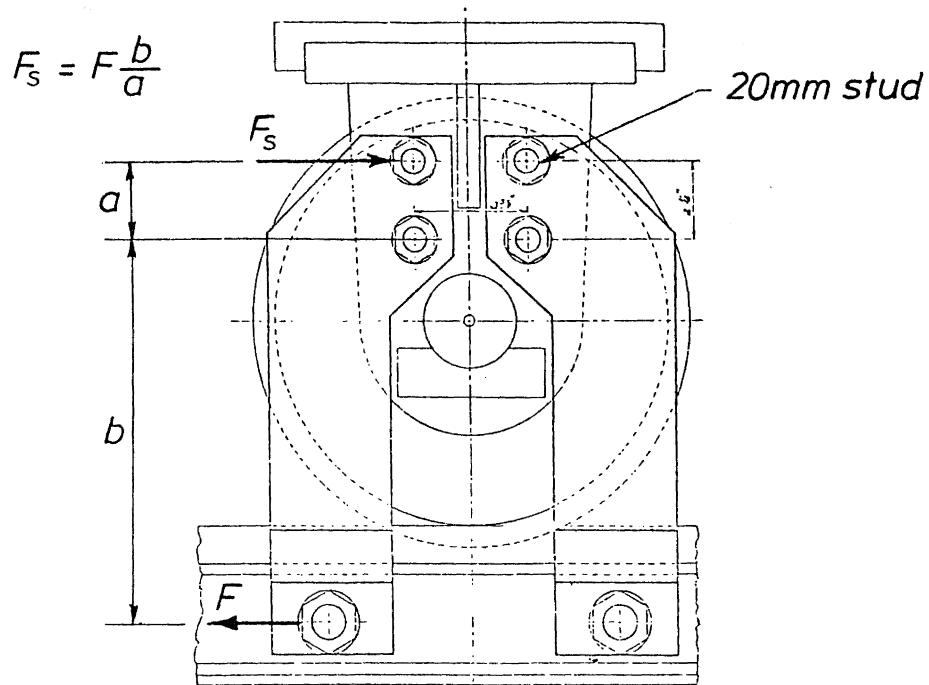

FIGURE 8 EDGE CUMBE T8 TRANSFORMERS - SHEAR FORCE ON 200MM STUDS

### Transformer Oil Pipes and Bucholz Relays

On the T6 and T7 110kV Tyree transformer coolers at Kawarau some failures of the cross bracing occurred and the resulting excessive movement lead to failure of the pipework at the conservator tank valve.

The Bucholz relays on T12 and T13 220/110kV interconnecting transformers at Kawarau failed and allowed oil to escape. This failure was probably either caused by excessive response of the pipe or by relative movement between the oil conservator and the transformer. The south block wall which forms the enclosure to contain the oil leaked from the transformer fell over. The wall was built with low strength mortar to allow easy removal when the transformers are shifted.

### 220 kV Buswork

The 220kV buswork at Kawarau was extensively damaged as in Figure 9. Numerous concrete posts which support the insulators and buswork cracked at the base [5]. Several long cross-over conductors pulled out of the interconnecting clamps and fell to the ground. One insulator on top of a tall concrete post was completely destroyed.

In general the damage to the 220kV buswork was easily repaired. The concrete posts were originally designed to yield at the base without failing completely.

### CONCLUSIONS FROM THE DAMAGE

#### Transformer Holding Down

The transformer damage at Edgumbe and Kawarau was to units that were not designed to current Electricorp earthquake standards for transformers first introduced in 1969.

For example at Edgumbe the Savigliano earthquake clamps were designed in 1967 and the clamps for the BTH were designed in 1953. The Ferranti clamps dated back to 1957 and the Westinghouse clamps are even earlier. On the other hand, the Osaka holding down design was installed in 1977 and survived well.

At Kawarau the T1 and T3 ASEA clamps were designed in 1955 and the clamps for the T2A Ferranti were designed in 1961. The fact that none of the in-service units came completely off the rails may have been because the predominant direction of ground shaking was parallel to the rails.

The shear failure of the fixings for the T5 AEI and T2A/T2B Ferranti transformers to their undercarriages demonstrates that an earthquake will expose the weakest part of the overall installation. The manufacturer's method of fixing the transformer tank to the undercarriage should always be checked when holding down arrangements are designed.

If the transformer fastenings had been upgraded to current Electricorp standards for earthquake design most of the damage would have been avoided.

#### Control Panel Holding Down

The failure of the control panels was due to bad working practice. The Unistrut system currently used by Electricorp for holding down panels is satisfactory when correctly installed.

All control panels coach screwed to wooden plinths should be tied back to a structural wall.

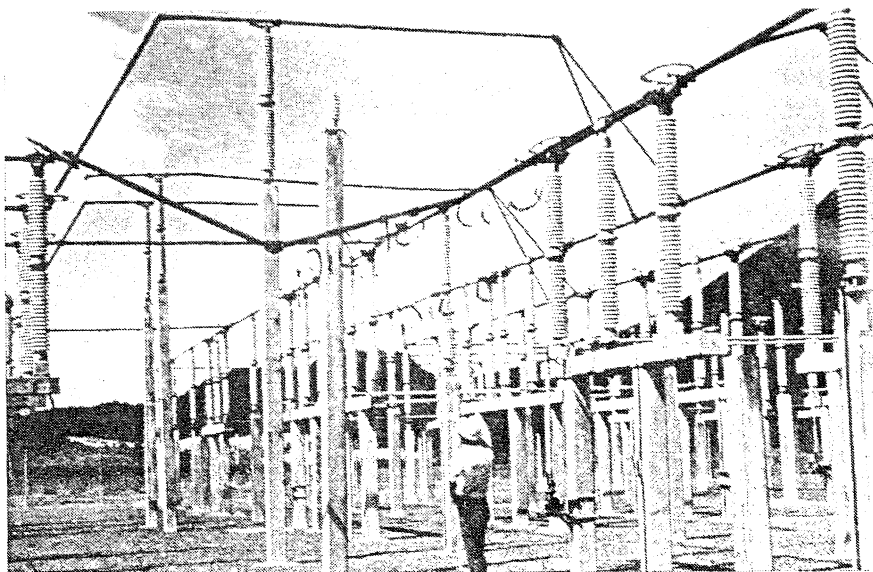

FIGURE 9 220KV BUSBAR DAMAGE AT KAWARAU

Current Transformers

In the assessment of overall strength of current transformers the strength of the end fixing arrangement should be considered. Furthermore the strength of the fixings for the internal windings should be checked.

Flexible Connections

Flexible connections that were installed with insufficient free length is the likely cause of failure of the Merlin Gerin 220kV FA2 CB at Edgumbe and the ASEA 110kV CB at Kawarau. Connections should be installed with a generous amount of slack even if it detracts from the overall tidy appearance of the installation.

Spares

Spares likely to topple in an earthquake should be secured to the floor or tied back to a wall.

Equipment that Survived

The most notable survivor of the earthquake was the Delle 220kV CBs at Edgumbe. As originally installed the breakers would not survive the Electricorp design earthquake. The breakers were retrofitted with Belville washer dampers to improve the earthquake resistance and this simple modification probably saved them from damage in the Edgumbe earthquake.

RECOMMENDATIONS FOR SUPPLY AUTHORITIES

The Bay of Plenty earthquake was a sharp reminder that electrical equipment is very vulnerable to damage if it is not designed to withstand earthquake induced forces or is not adequately held down. In November 1981 a set of notes was issued to all Supply Authority staff on the application of ESR61. This set of notes was prepared by NZE staff for a working group comprising Supply Authority and NZE engineers. The notes provide guidance on achieving an adequate degree of earthquake resistance for power houses and substations as required by the 1980 amendment to ESR 61 and its associated Gazette notice of 23 October 1980.

Supply Authority staff involved in the design of new installations or the upgrading of existing equipment should use the guidelines given in the notes and consult if necessary with engineers experienced in the earthquake resistant design of electrical equipment.

ACKNOWLEDGEMENTS

The author wishes to thank the Management of Electricorp for permission to publish this paper. The assistance of Mr Tan Pham in gathering material for this paper is gratefully acknowledged.

REFERENCES

1. Pender, M.J. et al, "The Edgumbe Earthquake - a Brief Report", April 1987.
2. Rutledge, A.L. and T. Pham, "The Bay of Plenty Earthquake - A Preliminary Assessment of Earthquake Damage at Kawarau and Edgumbe", Internal Electricorp report, March 1987.
3. Rutledge, A.L. and T. Pham, "Investigation of Equipment Failures in the Tokaanu Outdoor Switchyard due to the Earthquake of 5 March 1984", Electricorp Research Section Report No. R55/85, August 1985.
4. Pham, T., "Earthquake Failure of Merlin Gerin 220kV IA2 Circuit Breaker at Kawarau Substation", Electricorp Research Section Technical Note T87/41
5. Coad, J.N.O., "220kV Buswork Support Post Performance during the Bay of Plenty Earthquake", Electricorp Research Section Technical Note T87/39.